

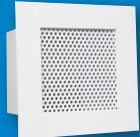

1310, 1310TF & 51310
These perforated face supply grilles feature 5/16" diameter holes on 7/16" staggered centers.

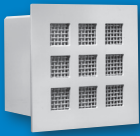

13SD
This perforated face supply grille features 3/16" diameter holes on 9/32" staggered centers.



1320
This lattice face supply grille features 2"x2" square holes and wire mesh between face plate and backer plate.



1330
This louvered face supply grille features a wire mesh between the mullion and mesh guard. Blades set horizontally at 40°.



1340
This lattice face with louvered core supply diffuser features 13/16" square holes and 3/16" fret.



51350
This aluminum supply and return grille features 3/16"x3/4" bars on 1/2" centers. Bars are set at 0° deflection.

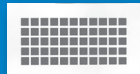

1380 & 51380
These lattice or perforated face plates feature 13/16" square holes with 3/16" fret or 5/16" diameter holes on 7/16" staggered centers.

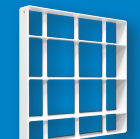

1390
This barred duct work features a vertical or horizontal security bar. Round bars are 3/4" diameter. Flat bars are 2 1/2"x1/4".



1390F
This barred duct work with sleeve features vertical and horizontal round security bars. Round bars are 3/4" diameter.

1310, 1310TF, 51310

Introduction & Dimensional Information L1-3
Reference Charts L1-5
Performance Data L1-7
Engineering Specification L1-12

13SD

Introduction & Dimensional Information L1-13
Reference Charts L1-14
Performance Data L1-16
Engineering Specification L1-21

1320

Introduction & Dimensional Information L1-22
Reference Charts L1-23
Performance Data L1-25
Engineering Specification L1-30

1330

Introduction & Dimensional Information L1-31
Reference Charts L1-32
Performance Data L1-34
Engineering Specification L1-39

1340

Introduction & Dimensional Information L1-40
Installation Details, Discharge Air Patterns, & Reference Chart L1-41
Performance Data L1-42
Engineering Specification L1-44

51350

Introduction & Dimensional Information L1-45
Reference Charts L1-46
Performance Data L1-48
Engineering Specification L1-53

1380L, 51380L, 1380P, 51380P

Introduction & Dimensional Information L1-54
Screw Hole Detail L1-55
Engineering Specification L1-56

1390

Introduction & Dimensional Information L1-57
Engineering Specification L1-58

1390F

Introduction & Dimensional Info L1-59
Engineering Specification L1-60

Security Grille Accessories

Dimensional Information L1-61

Introduction: 1330

The 1330 series medium/minimum security grilles feature a wire mesh placed behind a heavy duty bar grille with fixed 14 gage blades. This design allows for a secure area without the confining appearance of other security grilles. The heavy construction and wire mesh deter the insertion or concealment of dangerous objects and unwanted contraband.

MODEL

1330 - Medium/minimum security steel grille with fixed 14 gage blades set at 40° on 3/8" centers.

FEATURES

- 16 Gage frame.
- 10 Gage x #2 wire steel mesh.
- 14 Gage steel sleeve with wrap around corner construction and stitch welded seams.
- 30"x30" Maximum single unit size.
- 6", 8", 10", 12", 14", 16", and 18" Sleeve lengths.

ACCESSORIES

- Unpainted steel angle frame shipped loose for field installation, constructed of 1 1/2"x1 1/2"x3/16" angle.
- Steel 3/4" diameter security bars on 6" centers.
- Steel 3"x3/4" diameter anchor bars.
- Two unpainted loose steel angles shipped loose for field installation, constructed of 1 1/2"x1 1/2"x3/16" angle.
- Front or rear operated OBD.

FINISHES

- Standard finish is #44 British White.
- Optional finish is Mill.



1330

1330 Dimensional Information

1330, FACE VIEW

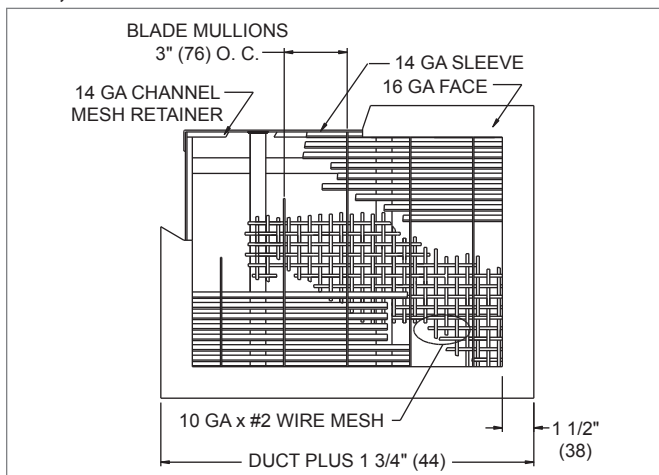

NOTE: Dimensions in parentheses are mm.

1330, CROSS SECTION

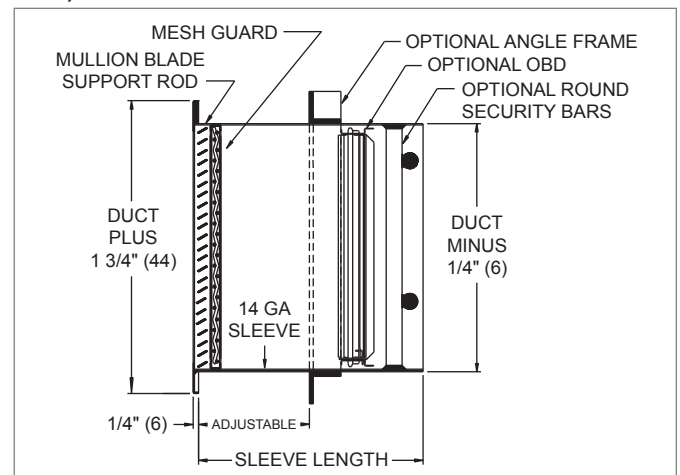

1330 Reference Charts

AIRFLOW VS. NC LEVEL: 1330 (NO DAMPER)

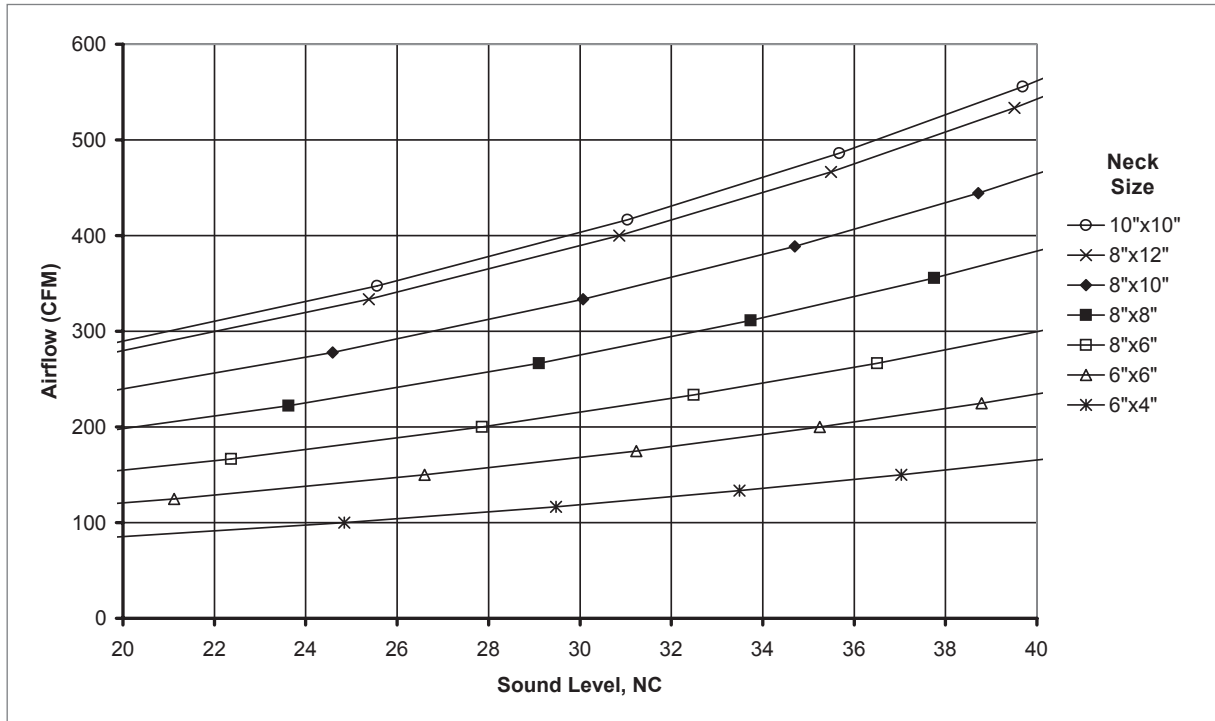

AIRFLOW VS. NC LEVEL: 1330 (NO DAMPER)

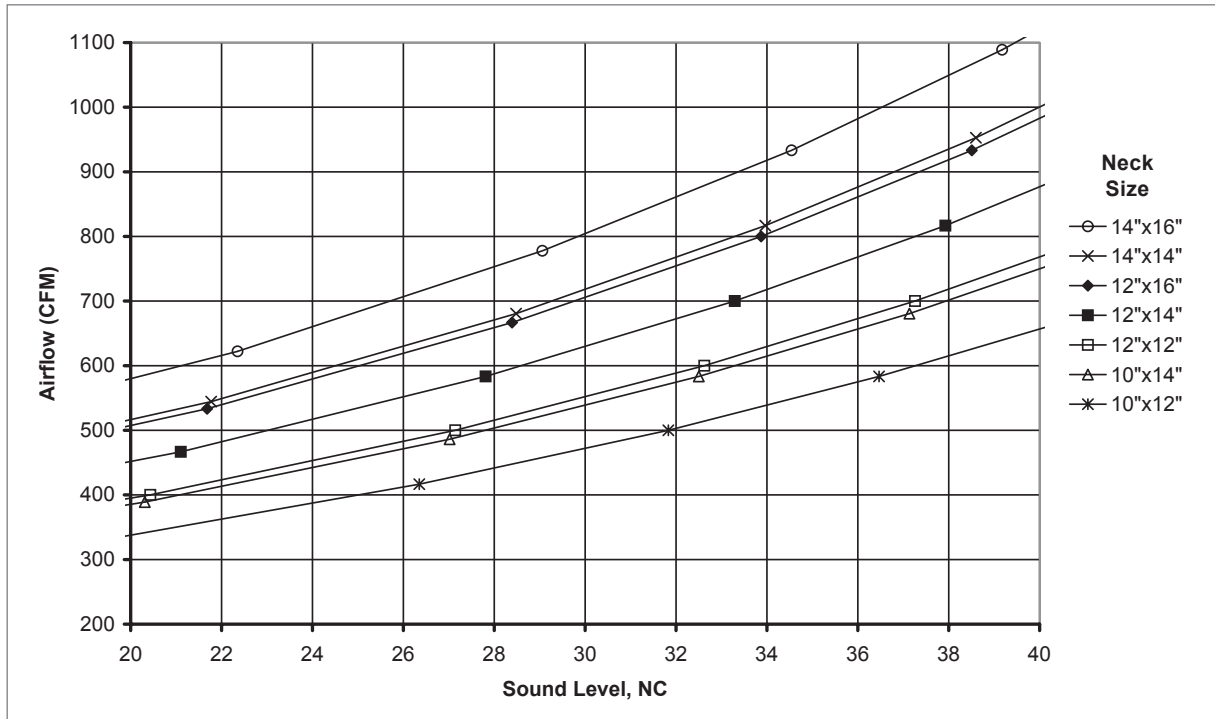

SECURITY GRILLES

1330

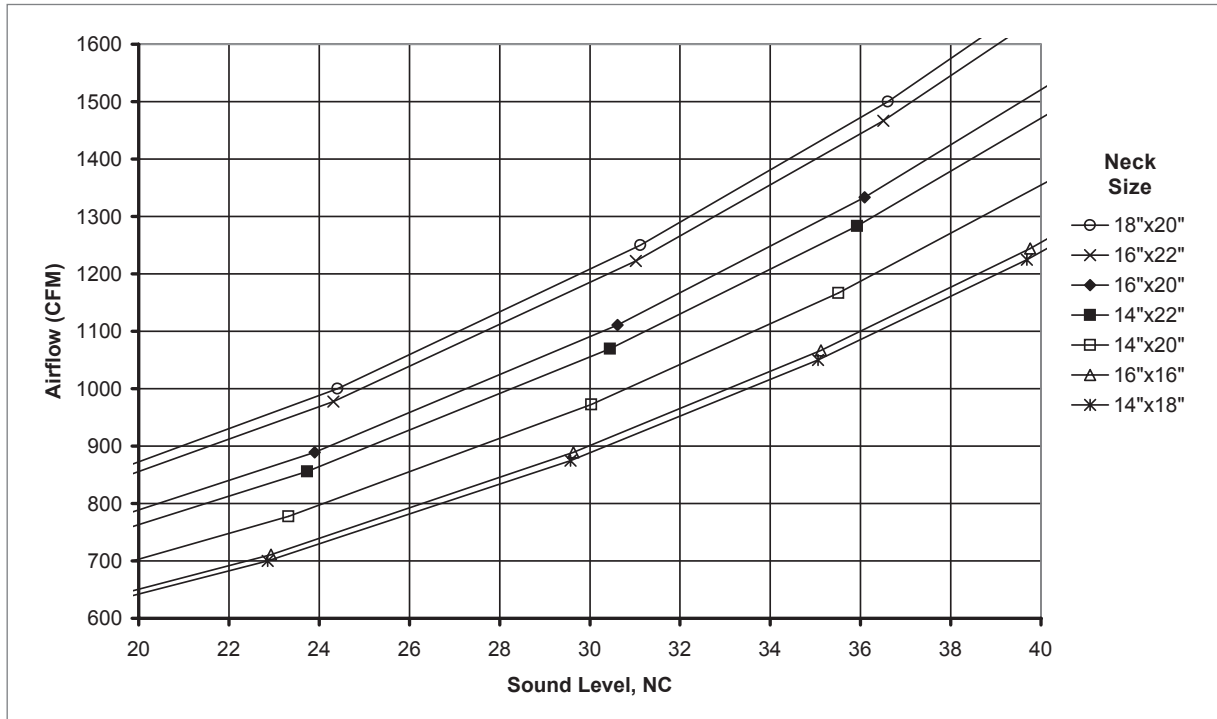
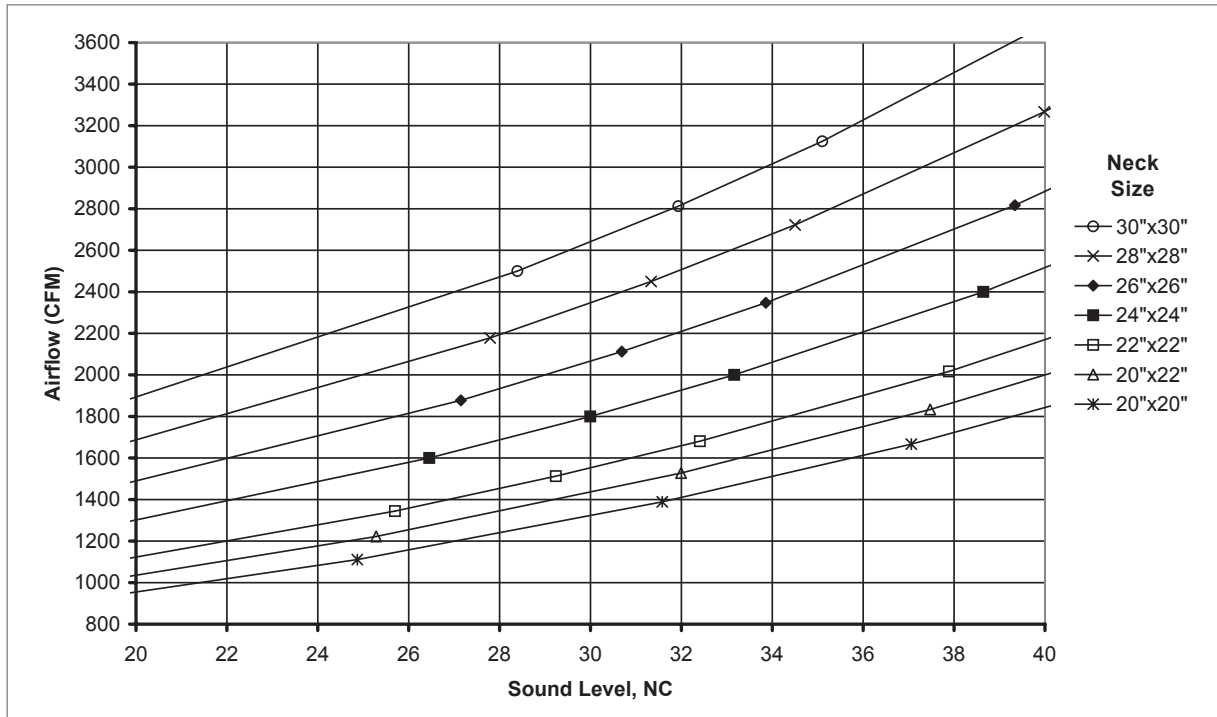
1330 Reference Charts
AIRFLOW VS. NC LEVEL: 1330 (NO DAMPER)

AIRFLOW VS. NC LEVEL: 1330 (NO DAMPER)

1330 Performance Data: Horizontal Throw

IP/METRIC DATA: 1330 (NO DAMPER)

IP Data							Metric Data					
Nom Duct	Duct Area	Neck Vel	Air Flow	Pt	Throw	NC	Nom Duct	Duct Area	Neck Vel	Air Flow	Pt	Throw
in	ft ²	FPM	CFM	"WG	ft		mm	m ²	m/s	L/s	Pa	m
6" x 4"	0.17	200	33	.018	2 - 5 - 9	-	152 x 102	0.02	1.02	16	4.5	0.7 - 1.5 - 2.8
		300	50	.040	5 - 8 - 11	-			1.52	24	10.1	1.5 - 2.4 - 3.4
		400	67	.072	8 - 9 - 13	13			2.03	31	17.9	2.3 - 2.8 - 4.0
		500	83	.112	8 - 10 - 15	19			2.54	39	28.0	2.6 - 3.1 - 4.4
		600	100	.162	9 - 11 - 16	25			3.05	47	40.3	2.8 - 3.4 - 4.9
		700	117	.220	10 - 12 - 17	29			3.56	55	54.8	3.0 - 3.7 - 5.2
		800	133	.288	11 - 13 - 18	33			4.06	63	71.6	3.2 - 4.0 - 5.6
		900	150	.364	11 - 14 - 20	37			4.57	71	90.6	3.4 - 4.2 - 5.9
		1000	167	.449	12 - 15 - 21	40	5.08	79	111.9	3.6 - 4.4 - 6.3		
6" x 6"	0.25	200	50	.018	3 - 6 - 11	-	152 x 152	0.02	1.02	24	4.5	0.8 - 1.8 - 3.4
		300	75	.040	6 - 10 - 14	-			1.52	35	10.1	1.8 - 3.0 - 4.2
		400	100	.072	9 - 11 - 16	14			2.03	47	17.9	2.8 - 3.4 - 4.9
		500	125	.112	10 - 13 - 18	21			2.54	59	28.0	3.1 - 3.8 - 5.4
		600	150	.162	11 - 14 - 20	27			3.05	71	40.3	3.4 - 4.2 - 5.9
		700	175	.220	12 - 15 - 21	31			3.56	83	54.8	3.7 - 4.5 - 6.4
		800	200	.288	13 - 16 - 23	35			4.06	94	71.6	4.0 - 4.9 - 6.9
		900	225	.364	14 - 17 - 24	39			4.57	106	90.6	4.2 - 5.2 - 7.3
		1000	250	.449	15 - 18 - 25	42	5.08	118	111.9	4.4 - 5.4 - 7.7		
8" x 6"	0.33	200	67	.018	3 - 7 - 13	-	203 x 152	0.03	1.02	31	4.5	0.9 - 2.1 - 4.0
		300	100	.040	7 - 11 - 16	-			1.52	47	10.1	2.1 - 3.4 - 4.9
		400	133	.072	11 - 13 - 18	16			2.03	63	17.9	3.2 - 4.0 - 5.6
		500	167	.112	12 - 15 - 21	22			2.54	79	28.0	3.6 - 4.4 - 6.3
		600	200	.162	13 - 16 - 23	28			3.05	94	40.3	4.0 - 4.9 - 6.9
		700	233	.220	14 - 17 - 24	32			3.56	110	54.8	4.3 - 5.2 - 7.4
		800	267	.288	15 - 18 - 26	37			4.06	126	71.6	4.6 - 5.6 - 7.9
		900	300	.364	16 - 20 - 28	40			4.57	142	90.6	4.9 - 5.9 - 8.4
		1000	333	.449	17 - 21 - 29	43	5.08	157	111.9	5.1 - 6.3 - 8.9		
8" x 8"	0.44	200	89	.018	4 - 8 - 15	-	203 x 203	0.04	1.02	42	4.5	1.1 - 2.4 - 4.6
		300	133	.040	8 - 13 - 18	-			1.52	63	10.1	2.4 - 4.0 - 5.6
		400	178	.072	12 - 15 - 21	17			2.03	84	17.9	3.7 - 4.6 - 6.5
		500	222	.112	14 - 17 - 24	24			2.54	105	28.0	4.2 - 5.1 - 7.2
		600	267	.162	15 - 18 - 26	29			3.05	126	40.3	4.6 - 5.6 - 7.9
		700	311	.220	16 - 20 - 28	34			3.56	147	54.8	4.9 - 6.1 - 8.6
		800	356	.288	17 - 21 - 30	38			4.06	168	71.6	5.3 - 6.5 - 9.2
		900	400	.364	18 - 23 - 32	41			4.57	189	90.6	5.6 - 6.9 - 9.7
		1000	444	.449	19 - 24 - 34	44	5.08	210	111.9	5.9 - 7.2 - 10.2		
8" x 10"	0.56	200	111	.018	4 - 9 - 17	-	203 x 254	0.05	1.02	52	4.5	1.2 - 2.7 - 5.1
		300	167	.040	9 - 15 - 21	-			1.52	79	10.1	2.7 - 4.4 - 6.3
		400	222	.072	14 - 17 - 24	18			2.03	105	17.9	4.2 - 5.1 - 7.2
		500	278	.112	15 - 19 - 27	25			2.54	131	28.0	4.7 - 5.7 - 8.1
		600	333	.162	17 - 21 - 29	30			3.05	157	40.3	5.1 - 6.3 - 8.9
		700	389	.220	18 - 22 - 32	35			3.56	184	54.8	5.5 - 6.8 - 9.6
		800	444	.288	19 - 24 - 34	39			4.06	210	71.6	5.9 - 7.2 - 10.2
		900	500	.364	21 - 25 - 36	42			4.57	236	90.6	6.3 - 7.7 - 10.9
		1000	556	.449	22 - 27 - 38	45	5.08	262	111.9	6.6 - 8.1 - 11.5		
8" x 12"	0.67	200	133	.018	4 - 10 - 18	-	203 x 305	0.06	1.02	63	4.5	1.3 - 3.0 - 5.6
		300	200	.040	10 - 16 - 23	-			1.52	94	10.1	3.0 - 4.9 - 6.9
		400	267	.072	15 - 18 - 26	19			2.03	126	17.9	4.6 - 5.6 - 7.9
		500	333	.112	17 - 21 - 29	25			2.54	157	28.0	5.1 - 6.3 - 8.9
		600	400	.162	18 - 23 - 32	31			3.05	189	40.3	5.6 - 6.9 - 9.7
		700	467	.220	20 - 24 - 35	35			3.56	220	54.8	6.1 - 7.4 - 10.5
		800	533	.288	21 - 26 - 37	40			4.06	252	71.6	6.5 - 7.9 - 11.2
		900	600	.364	23 - 28 - 39	43			4.57	283	90.6	6.9 - 8.4 - 11.9
		1000	667	.449	24 - 29 - 41	46	5.08	315	111.9	7.2 - 8.9 - 12.5		

SECURITY GRILLES

1 NOTES: Throw values are given for isothermal conditions and terminal velocities of 150, 100, and 50 FPM (0.75, 0.50, and 0.25 m/s). NC values
 3 are based on octave band 2 - 7 sound power levels minus a room absorption of 10dB, re 10⁻¹² Watts. Dash in space denotes a NC value of less
 3 than 10. Data was obtained from tests conducted in accordance with ANSI/ASHRAE Standard 70, ISO Standard 5219, and ISO Standard 3741.
 0 See Krueger's selection program for performance data not shown, including octave band data.

© KRUEGER 2012

1330 Performance Data: Horizontal Throw

IP/METRIC DATA: 1330 (NO DAMPER)

IP Data							Metric Data					
Nom Duct	Duct Area	Neck Vel	Air Flow	Pt	Throw	NC	Nom Duct	Duct Area	Neck Vel	Air Flow	Pt	Throw
in	ft ²	FPM	CFM	"WG	ft		mm	m ²	m/s	L/s	Pa	m
10" x 10"	0.69	200	139	.018	4 - 10 - 19	-	254 x 254	0.06	1.02	66	4.5	1.3 - 3.0 - 5.7
		300	208	.040	10 - 16 - 23	-			1.52	98	10.1	3.0 - 5.0 - 7.0
		400	278	.072	15 - 19 - 27	19			2.03	131	17.9	4.7 - 5.7 - 8.1
		500	347	.112	17 - 21 - 30	26			2.54	164	28.0	5.2 - 6.4 - 9.1
		600	417	.162	19 - 23 - 33	31			3.05	197	40.3	5.7 - 7.0 - 9.9
		700	486	.220	20 - 25 - 35	36			3.56	229	54.8	6.2 - 7.6 - 10.7
		800	556	.288	22 - 27 - 38	40			4.06	262	71.6	6.6 - 8.1 - 11.5
		900	625	.364	23 - 28 - 40	43			4.57	295	90.6	7.0 - 8.6 - 12.1
		1000	694	.449	24 - 30 - 42	46	5.08	328	111.9	7.4 - 9.1 - 12.8		
10" x 12"	0.83	100	83	.005	1 - 3 - 11	-	254 x 305	0.08	0.51	39	1.1	0.4 - 0.8 - 3.3
		200	167	.018	5 - 11 - 21	-			1.02	79	4.5	1.5 - 3.3 - 6.3
		250	208	.028	8 - 16 - 23	-			1.27	98	7.0	2.3 - 5.0 - 7.0
		300	250	.040	11 - 18 - 25	11			1.52	118	10.1	3.3 - 5.4 - 7.7
		400	333	.072	17 - 21 - 29	20			2.03	157	17.9	5.1 - 6.3 - 8.9
		500	417	.112	19 - 23 - 33	26			2.54	197	28.0	5.7 - 7.0 - 9.9
		600	500	.162	21 - 25 - 36	32			3.05	236	40.3	6.3 - 7.7 - 10.9
		700	583	.220	22 - 27 - 39	36			3.56	275	54.8	6.8 - 8.3 - 11.7
		800	667	.288	24 - 29 - 41	40	4.06	315	71.6	7.2 - 8.9 - 12.5		
10" x 14"	0.97	100	97	.004	1 - 3 - 12	-	254 x 356	0.09	0.51	46	1.1	0.4 - 0.9 - 3.6
		200	194	.017	5 - 12 - 22	-			1.02	92	4.3	1.6 - 3.6 - 6.8
		250	243	.027	8 - 18 - 25	-			1.27	115	6.6	2.5 - 5.4 - 7.6
		300	292	.038	12 - 19 - 27	12			1.52	138	9.6	3.6 - 5.9 - 8.3
		400	389	.068	18 - 22 - 32	20			2.03	184	17.0	5.5 - 6.8 - 9.6
		500	486	.107	20 - 25 - 35	27			2.54	229	26.6	6.2 - 7.6 - 10.7
		600	583	.154	22 - 27 - 39	33			3.05	275	38.3	6.8 - 8.3 - 11.7
		700	681	.209	24 - 29 - 42	37			3.56	321	52.1	7.3 - 9.0 - 12.7
		800	778	.273	26 - 32 - 45	41	4.06	367	68.1	7.8 - 9.6 - 13.5		
12" x 12"	1.00	100	100	.004	1 - 3 - 12	-	305 x 305	0.09	0.51	47	1.1	0.4 - 0.9 - 3.6
		200	200	.017	5 - 12 - 23	-			1.02	94	4.3	1.6 - 3.6 - 6.9
		250	250	.027	8 - 18 - 25	-			1.27	118	6.6	2.5 - 5.4 - 7.7
		300	300	.038	12 - 20 - 28	12			1.52	142	9.6	3.6 - 5.9 - 8.4
		400	400	.068	18 - 23 - 32	20			2.03	189	17.0	5.6 - 6.9 - 9.7
		500	500	.107	21 - 25 - 36	27			2.54	236	26.6	6.3 - 7.7 - 10.9
		600	600	.154	23 - 28 - 39	33			3.05	283	38.3	6.9 - 8.4 - 11.9
		700	700	.209	24 - 30 - 42	37			3.56	330	52.1	7.4 - 9.1 - 12.9
		800	800	.273	26 - 32 - 45	41	4.06	378	68.1	7.9 - 9.7 - 13.7		
12" x 14"	1.17	100	117	.004	1 - 3 - 13	-	305 x 356	0.11	0.51	55	1.1	0.4 - 1.0 - 3.9
		200	233	.017	6 - 13 - 24	-			1.02	110	4.3	1.7 - 3.9 - 7.4
		250	292	.027	9 - 19 - 27	-			1.27	138	6.6	2.7 - 5.9 - 8.3
		300	350	.038	13 - 21 - 30	12			1.52	165	9.6	3.9 - 6.4 - 9.1
		400	467	.068	20 - 24 - 35	21			2.03	220	17.0	6.1 - 7.4 - 10.5
		500	583	.107	22 - 27 - 39	28			2.54	275	26.6	6.8 - 8.3 - 11.7
		600	700	.154	24 - 30 - 42	33			3.05	330	38.3	7.4 - 9.1 - 12.9
		700	817	.209	26 - 32 - 46	38			3.56	385	52.1	8.0 - 9.8 - 13.9
		800	933	.273	28 - 35 - 49	42	4.06	440	68.1	8.6 - 10.5 - 14.8		
12" x 16"	1.33	100	133	.004	2 - 3 - 14	-	305 x 406	0.12	0.51	63	1.1	0.5 - 1.0 - 4.2
		200	267	.017	6 - 14 - 26	-			1.02	126	4.3	1.9 - 4.2 - 7.9
		250	333	.027	10 - 21 - 29	-			1.27	157	6.6	2.9 - 6.3 - 8.9
		300	400	.038	14 - 23 - 32	13			1.52	189	9.6	4.2 - 6.9 - 9.7
		400	533	.068	21 - 26 - 37	22			2.03	252	17.0	6.5 - 7.9 - 11.2
		500	667	.107	24 - 29 - 41	28			2.54	315	26.6	7.2 - 8.9 - 12.5
		600	800	.154	26 - 32 - 45	34			3.05	378	38.3	7.9 - 9.7 - 13.7
		700	933	.209	28 - 35 - 49	39			3.56	440	52.1	8.6 - 10.5 - 14.8
		800	1067	.273	30 - 37 - 52	43	4.06	503	68.1	9.2 - 11.2 - 15.9		

NOTES: Throw values are given for isothermal conditions and terminal velocities of 150, 100, and 50 FPM (0.75, 0.50, and 0.25 m/s). NC values are based on octave band 2 - 7 sound power levels minus a room absorption of 10dB, re 10⁻¹² Watts. Dash in space denotes a NC value of less than 10. Data was obtained from tests conducted in accordance with ANSI/ASHRAE Standard 70, ISO Standard 5219, and ISO Standard 3741. See Krueger's selection program for performance data not shown, including octave band data.

1330 | Heavy Duty Bar Grille with Wire Mesh

1330 Performance Data: Horizontal Throw

IP/METRIC DATA: 1330 (NO DAMPER)

IP Data							Metric Data					
Nom Duct	Duct Area	Neck Vel	Air Flow	Pt	Throw	NC	Nom Duct	Duct Area	Neck Vel	Air Flow	Pt	Throw
in	ft²	FPM	CFM	"WG	ft		mm	m²	m/s	L/s	Pa	m
14" x 14"	1.36	100	136	.004	2 - 3 - 14	-	356 x 356	0.13	0.51	64	1.1	0.5 - 1.1 - 4.2
		200	272	.017	6 - 14 - 26	-			1.02	128	4.3	1.9 - 4.2 - 8.0
		250	340	.027	10 - 21 - 29	-			1.27	161	6.6	2.9 - 6.3 - 9.0
		300	408	.038	14 - 23 - 32	13			1.52	193	9.6	4.2 - 6.9 - 9.8
		400	544	.068	22 - 26 - 37	22			2.03	257	17.0	6.5 - 8.0 - 11.3
		500	681	.107	24 - 29 - 42	28			2.54	321	26.6	7.3 - 9.0 - 12.7
		600	817	.154	26 - 32 - 46	34			3.05	385	38.3	8.0 - 9.8 - 13.9
		700	953	.209	28 - 35 - 49	39			3.56	450	52.1	8.7 - 10.6 - 15.0
800	1089	.273	30 - 37 - 53	43	4.06	514	68.1	9.3 - 11.3 - 16.0				
14" x 16"	1.56	100	156	.004	2 - 4 - 15	-	356 x 406	0.14	0.51	73	1.1	0.5 - 1.1 - 4.5
		200	311	.017	7 - 15 - 28	-			1.02	147	4.3	2.0 - 4.5 - 8.6
		250	389	.027	10 - 22 - 32	-			1.27	184	6.6	3.1 - 6.8 - 9.6
		300	467	.038	15 - 24 - 35	14			1.52	220	9.6	4.5 - 7.4 - 10.5
		400	622	.068	23 - 28 - 40	22			2.03	294	17.0	7.0 - 8.6 - 12.1
		500	778	.107	26 - 32 - 45	29			2.54	367	26.6	7.8 - 9.6 - 13.5
		600	933	.154	28 - 35 - 49	35			3.05	440	38.3	8.6 - 10.5 - 14.8
		700	1089	.209	30 - 37 - 53	39			3.56	514	52.1	9.3 - 11.3 - 16.0
800	1244	.273	33 - 40 - 56	43	4.06	587	68.1	9.9 - 12.1 - 17.1				
14" x 18"	1.75	100	175	.005	2 - 4 - 16	-	356 x 457	0.16	0.51	83	1.1	0.5 - 1.2 - 4.8
		200	350	.018	7 - 16 - 30	-			1.02	165	4.5	2.1 - 4.8 - 9.1
		250	438	.028	11 - 24 - 33	-			1.27	206	7.0	3.3 - 7.2 - 10.2
		300	525	.040	16 - 26 - 37	14			1.52	248	10.1	4.8 - 7.9 - 11.1
		400	700	.072	24 - 30 - 42	23			2.03	330	17.9	7.4 - 9.1 - 12.9
		500	875	.112	27 - 33 - 47	30			2.54	413	28.0	8.3 - 10.2 - 14.4
		600	1050	.162	30 - 37 - 52	35			3.05	496	40.3	9.1 - 11.1 - 15.7
		700	1225	.220	32 - 40 - 56	40			3.56	578	54.8	9.8 - 12.0 - 17.0
800	1400	.288	35 - 42 - 60	44	4.06	661	71.6	10.5 - 12.9 - 18.2				
16" x 16"	1.78	100	178	.004	2 - 4 - 16	-	406 x 406	0.17	0.51	84	1.1	0.5 - 1.2 - 4.8
		200	356	.017	7 - 16 - 30	-			1.02	168	4.3	2.2 - 4.8 - 9.2
		250	444	.027	11 - 24 - 34	-			1.27	210	6.6	3.4 - 7.2 - 10.2
		300	533	.038	16 - 26 - 37	14			1.52	252	9.6	4.8 - 7.9 - 11.2
		400	711	.068	25 - 30 - 43	23			2.03	336	17.0	7.5 - 9.2 - 13.0
		500	889	.107	28 - 34 - 48	30			2.54	420	26.6	8.4 - 10.2 - 14.5
		600	1067	.154	30 - 37 - 52	35			3.05	503	38.3	9.2 - 11.2 - 15.9
		700	1244	.209	33 - 40 - 56	40			3.56	587	52.1	9.9 - 12.1 - 17.1
800	1422	.273	35 - 43 - 60	44	4.06	671	68.1	10.6 - 13.0 - 18.3				
14" x 20"	1.94	100	194	.004	2 - 4 - 17	-	356 x 508	0.18	0.51	92	1.1	0.6 - 1.3 - 5.1
		200	389	.017	7 - 17 - 32	-			1.02	184	4.3	2.3 - 5.1 - 9.6
		250	486	.027	12 - 25 - 35	-			1.27	229	6.6	3.5 - 7.6 - 10.7
		300	583	.038	17 - 27 - 39	15			1.52	275	9.6	5.1 - 8.3 - 11.7
		400	778	.068	26 - 32 - 45	23			2.03	367	17.0	7.8 - 9.6 - 13.5
		500	972	.107	29 - 35 - 50	30			2.54	459	26.6	8.7 - 10.7 - 15.1
		600	1167	.154	32 - 39 - 55	36			3.05	551	38.3	9.6 - 11.7 - 16.6
		700	1361	.209	34 - 42 - 59	40			3.56	642	52.1	10.3 - 12.7 - 17.9
800	1556	.273	36 - 45 - 63	44	4.06	734	68.1	11.1 - 13.5 - 19.2				
14" x 22"	2.14	100	214	.004	2 - 4 - 17	-	356 x 559	0.20	0.51	101	1.1	0.6 - 1.3 - 5.3
		200	428	.017	8 - 17 - 33	-			1.02	202	4.3	2.4 - 5.3 - 10.0
		250	535	.027	12 - 26 - 37	-			1.27	252	6.6	3.7 - 7.9 - 11.2
		300	642	.038	17 - 29 - 40	15			1.52	303	9.6	5.3 - 8.7 - 12.3
		400	856	.068	27 - 33 - 47	24			2.03	404	17.0	8.2 - 10.0 - 14.2
		500	1069	.107	30 - 37 - 52	30			2.54	505	26.6	9.2 - 11.2 - 15.9
		600	1283	.154	33 - 40 - 57	36			3.05	606	38.3	10.0 - 12.3 - 17.4
		700	1497	.209	36 - 44 - 62	41			3.56	707	52.1	10.9 - 13.3 - 18.8
800	1711	.273	38 - 47 - 66	45	4.06	808	68.1	11.6 - 14.2 - 20.1				

SECURITY GRILLES

1 NOTES: Throw values are given for isothermal conditions and terminal velocities of 150, 100, and 50 FPM (0.75, 0.50, and 0.25 m/s). NC values
 3 are based on octave band 2 - 7 sound power levels minus a room absorption of 10dB, re 10⁻¹² Watts. Dash in space denotes a NC value of less
 3 than 10. Data was obtained from tests conducted in accordance with ANSI/ASHRAE Standard 70, ISO Standard 5219, and ISO Standard 3741.
 0 See Krueger's selection program for performance data not shown, including octave band data.

© KRUEGER 2012

1330 Performance Data: Horizontal Throw

IP/METRIC DATA: 1330 (NO DAMPER)

IP Data						Metric Data						
Nom Duct	Duct Area	Neck Vel	Air Flow	Pt	Throw	NC	Nom Duct	Duct Area	Neck Vel	Air Flow	Pt	Throw
in	ft ²	FPM	CFM	"WG	ft		mm	m ²	m/s	L/s	Pa	m
16" x 20"	2.22	100	222	.004	2 - 4 - 18	-	406 x 508	0.21	0.51	105	1.1	0.6 - 1.4 - 5.4
		200	444	.017	8 - 18 - 34	-			1.02	210	4.3	2.4 - 5.4 - 10.2
		250	556	.027	12 - 27 - 38	-			1.27	262	6.6	3.8 - 8.1 - 11.5
		300	667	.038	18 - 29 - 41	15			1.52	315	9.6	5.4 - 8.9 - 12.5
		400	889	.068	28 - 34 - 48	24			2.03	420	17.0	8.4 - 10.2 - 14.5
		500	1111	.107	31 - 38 - 53	31			2.54	524	26.6	9.3 - 11.5 - 16.2
		600	1333	.154	34 - 41 - 58	36			3.05	629	38.3	10.2 - 12.5 - 17.7
		700	1556	.209	36 - 45 - 63	41			3.56	734	52.1	11.1 - 13.5 - 19.2
800	1778	.273	39 - 48 - 67	45	4.06	839	68.1	11.8 - 14.5 - 20.5				
16" x 22"	2.44	100	244	.004	2 - 5 - 19	-	406 x 559	0.23	0.51	115	1.1	0.6 - 1.4 - 5.7
		200	489	.017	8 - 19 - 35	-			1.02	231	4.3	2.5 - 5.7 - 10.7
		250	611	.027	13 - 28 - 40	-			1.27	288	6.6	3.9 - 8.5 - 12.0
		300	733	.038	19 - 31 - 43	16			1.52	346	9.6	5.7 - 9.3 - 13.2
		400	978	.068	29 - 35 - 50	24			2.03	461	17.0	8.8 - 10.7 - 15.2
		500	1222	.107	32 - 40 - 56	31			2.54	577	26.6	9.8 - 12.0 - 17.0
		600	1467	.154	35 - 43 - 61	37			3.05	692	38.3	10.7 - 13.2 - 18.6
		700	1711	.209	38 - 47 - 66	41			3.56	808	52.1	11.6 - 14.2 - 20.1
800	1956	.273	41 - 50 - 71	45	4.06	923	68.1	12.4 - 15.2 - 21.5				
18" x 20"	2.50	100	250	.004	2 - 5 - 19	-	457 x 508	0.23	0.51	118	1.1	0.6 - 1.4 - 5.7
		200	500	.017	8 - 19 - 36	-			1.02	236	4.3	2.6 - 5.7 - 10.9
		250	625	.027	13 - 28 - 40	-			1.27	295	6.6	4.0 - 8.6 - 12.1
		300	750	.038	19 - 31 - 44	16			1.52	354	9.6	5.7 - 9.4 - 13.3
		400	1000	.068	29 - 36 - 51	24			2.03	472	17.0	8.9 - 10.9 - 15.4
		500	1250	.107	33 - 40 - 57	31			2.54	590	26.6	9.9 - 12.1 - 17.2
		600	1500	.154	36 - 44 - 62	37			3.05	708	38.3	10.9 - 13.3 - 18.8
		700	1750	.209	39 - 47 - 67	41			3.56	826	52.1	11.7 - 14.4 - 20.3
800	2000	.273	41 - 51 - 71	45	4.06	944	68.1	12.5 - 15.4 - 21.7				
20" x 20"	2.78	100	278	.005	2 - 5 - 20	-	508 x 508	0.26	0.51	131	1.1	0.7 - 1.5 - 6.1
		200	556	.018	9 - 20 - 38	-			1.02	262	4.5	2.7 - 6.1 - 11.5
		250	694	.028	14 - 30 - 42	11			1.27	328	7.0	4.2 - 9.1 - 12.8
		300	833	.040	20 - 33 - 46	16			1.52	393	10.1	6.1 - 9.9 - 14.0
		400	1111	.072	31 - 38 - 53	25			2.03	524	17.9	9.3 - 11.5 - 16.2
		500	1389	.112	34 - 42 - 60	32			2.54	655	28.0	10.5 - 12.8 - 18.1
		600	1667	.162	38 - 46 - 65	37			3.05	787	40.3	11.5 - 14.0 - 19.8
		700	1944	.220	41 - 50 - 70	42			3.56	918	54.8	12.4 - 15.1 - 21.4
800	2222	.288	43 - 53 - 75	46	4.06	1049	71.6	13.2 - 16.2 - 22.9				
20" x 22"	3.06	100	306	.004	2 - 5 - 21	-	508 x 559	0.28	0.51	144	1.1	0.7 - 1.6 - 6.4
		200	611	.017	9 - 21 - 40	-			1.02	288	4.3	2.8 - 6.4 - 12.0
		250	764	.027	15 - 31 - 44	11			1.27	361	6.6	4.4 - 9.5 - 13.4
		300	917	.038	21 - 34 - 48	17			1.52	433	9.6	6.4 - 10.4 - 14.7
		400	1222	.068	32 - 40 - 56	25			2.03	577	17.0	9.8 - 12.0 - 17.0
		500	1528	.107	36 - 44 - 62	32			2.54	721	26.6	11.0 - 13.4 - 19.0
		600	1833	.154	40 - 48 - 68	37			3.05	865	38.3	12.0 - 14.7 - 20.8
		700	2139	.209	43 - 52 - 74	42			3.56	1009	52.1	13.0 - 15.9 - 22.5
800	2444	.273	46 - 56 - 79	46	4.06	1154	68.1	13.9 - 17.0 - 24.0				
22" x 22"	3.36	100	336	.004	2 - 5 - 22	-	559 x 559	0.31	0.51	159	1.1	0.7 - 1.7 - 6.7
		200	672	.017	10 - 22 - 41	-			1.02	317	4.3	3.0 - 6.7 - 12.6
		250	840	.027	15 - 33 - 46	12			1.27	397	6.6	4.6 - 10.0 - 14.1
		300	1008	.038	22 - 36 - 51	17			1.52	476	9.6	6.7 - 10.9 - 15.4
		400	1344	.068	34 - 41 - 59	26			2.03	635	17.0	10.3 - 12.6 - 17.8
		450	1513	.086	36 - 44 - 62	29			2.29	714	21.5	10.9 - 13.4 - 18.9
		500	1681	.107	38 - 46 - 66	32			2.54	793	26.6	11.5 - 14.1 - 19.9
		600	2017	.154	41 - 51 - 72	38			3.05	952	38.3	12.6 - 15.4 - 21.8
700	2353	.209	45 - 55 - 78	43	3.56	1110	52.1	13.6 - 16.7 - 23.6				

NOTES: Throw values are given for isothermal conditions and terminal velocities of 150, 100, and 50 FPM (0.75, 0.50, and 0.25 m/s). NC values are based on octave band 2 - 7 sound power levels minus a room absorption of 10dB, re 10⁻¹² Watts. Dash in space denotes a NC value of less than 10. Data was obtained from tests conducted in accordance with ANSI/ASHRAE Standard 70, ISO Standard 5219, and ISO Standard 3741. See Krueger's selection program for performance data not shown, including octave band data.

1330 | Heavy Duty Bar Grille with Wire Mesh

1330 Performance Data: Horizontal Throw

IP/METRIC DATA: 1330 (NO DAMPER)

IP Data							Metric Data					
Nom Duct	Duct Area	Neck Vel	Air Flow	Pt	Throw	NC	Nom Duct	Duct Area	Neck Vel	Air Flow	Pt	Throw
in	ft²	FPM	CFM	"WG	ft		mm	m²	m/s	L/s	Pa	m
24" x 24"	4.00	100	400	.004	3 - 6 - 24	-	610 x 610	0.37	0.51	189	1.1	0.8 - 1.8 - 7.3
		200	800	.017	11 - 24 - 45	-			1.02	378	4.3	3.2 - 7.3 - 13.7
		250	1000	.027	17 - 36 - 51	12			1.27	472	6.6	5.0 - 10.9 - 15.4
		300	1200	.038	24 - 39 - 55	18			1.52	566	9.6	7.3 - 11.9 - 16.8
		400	1600	.068	37 - 45 - 64	26			2.03	755	17.0	11.2 - 13.7 - 19.4
		450	1800	.086	39 - 48 - 68	30			2.29	850	21.5	11.9 - 14.6 - 20.6
		500	2000	.107	41 - 51 - 71	33			2.54	944	26.6	12.5 - 15.4 - 21.7
		600	2400	.154	45 - 55 - 78	39			3.05	1133	38.3	13.7 - 16.8 - 23.8
		700	2800	.209	49 - 60 - 85	43	3.56	1321	52.1	14.8 - 18.2 - 25.7		
26" x 26"	4.69	100	469	.004	3 - 6 - 26	-	660 x 660	0.44	0.51	222	1.1	0.9 - 2.0 - 7.9
		200	939	.017	12 - 26 - 49	-			1.02	443	4.3	3.5 - 7.9 - 14.9
		250	1174	.027	18 - 39 - 55	13			1.27	554	6.6	5.5 - 11.8 - 16.6
		300	1408	.038	26 - 42 - 60	18			1.52	665	9.6	7.9 - 12.9 - 18.2
		400	1878	.068	40 - 49 - 69	27			2.03	886	17.0	12.2 - 14.9 - 21.1
		450	2113	.086	42 - 52 - 73	31			2.29	997	21.5	12.9 - 15.8 - 22.3
		500	2347	.107	45 - 55 - 77	34			2.54	1108	26.6	13.6 - 16.6 - 23.5
		600	2817	.154	49 - 60 - 85	39			3.05	1329	38.3	14.9 - 18.2 - 25.8
		700	3286	.209	53 - 65 - 92	44	3.56	1551	52.1	16.1 - 19.7 - 27.8		
28" x 28"	5.44	100	544	.004	3 - 7 - 28	-	711 x 711	0.51	0.51	257	1.1	0.9 - 2.1 - 8.5
		200	1089	.017	12 - 28 - 53	-			1.02	514	4.3	3.8 - 8.5 - 16.0
		250	1361	.027	19 - 42 - 59	14			1.27	642	6.6	5.9 - 12.7 - 17.9
		300	1633	.038	28 - 46 - 65	19			1.52	771	9.6	8.5 - 13.9 - 19.6
		400	2178	.068	43 - 53 - 75	28			2.03	1028	17.0	13.1 - 16.0 - 22.7
		450	2450	.086	46 - 56 - 79	31			2.29	1156	21.5	13.9 - 17.0 - 24.0
		500	2722	.107	48 - 59 - 83	35			2.54	1285	26.6	14.6 - 17.9 - 25.3
		600	3267	.154	53 - 65 - 91	40			3.05	1542	38.3	16.0 - 19.6 - 27.8
		700	3811	.209	57 - 70 - 99	45	3.56	1799	52.1	17.3 - 21.2 - 30.0		
30" x 30"	6.25	100	625	.004	3 - 7 - 30	-	762 x 762	0.58	0.51	295	1.1	1.0 - 2.3 - 9.1
		200	1250	.017	13 - 30 - 57	-			1.02	590	4.3	4.0 - 9.1 - 17.2
		250	1563	.027	21 - 45 - 63	14			1.27	737	6.6	6.3 - 13.6 - 19.2
		300	1875	.038	30 - 49 - 69	20			1.52	885	9.6	9.1 - 14.9 - 21.0
		400	2500	.068	46 - 57 - 80	28			2.03	1180	17.0	14.0 - 17.2 - 24.3
		450	2813	.086	49 - 60 - 85	32			2.29	1327	21.5	14.9 - 18.2 - 25.8
		500	3125	.107	52 - 63 - 89	35			2.54	1475	26.6	15.7 - 19.2 - 27.2
		600	3750	.154	57 - 69 - 98	41			3.05	1770	38.3	17.2 - 21.0 - 29.7
		700	4375	.209	61 - 75 - 106	45	3.56	2065	52.1	18.6 - 22.7 - 32.1		

NOTES: Throw values are given for isothermal conditions and terminal velocities of 150, 100, and 50 FPM (0.75, 0.50, and 0.25 m/s). NC values are based on octave band 2 - 7 sound power levels minus a room absorption of 10dB, re 10⁻¹² Watts. Dash in space denotes a NC value of less than 10. Data was obtained from tests conducted in accordance with ANSI/ASHRAE Standard 70, ISO Standard 5219, and ISO Standard 3741. See Krueger's selection program for performance data not shown, including octave band data.

SECURITY GRILLES

1
3
3
0

© KRUEGER 2012

1330 Suggested Specification & Configuration

- 1. SERIES: (XXXX)**
1330 - Supply and Return Steel Security Grille
- 2. WIDTH: (XX)**
6" - 30" in 2" Increments, or 9"
- 3. HEIGHT: (XX)**
4" - 30" in 2" Increments, or 9"
- 4. SLEEVE LENGTH: (XX)**
6", 8", 10", 12", 14", 16", or 18"
- 5. DAMPER: (XX)**
00 - No Damper
3F - Front Operated Steel OBD *
3R - Rear Operated Steel OBD *
- 6. ACCESSORIES: (XX) (XX)**
00 - No Accessories
0L - Angle Frame Shipped Unpainted and Loose for Field Installation
01 - Security Bars, 3/4" Diameter Round Steel Bar on 6" Centers
02 - Anchor Bars, 3/4" Diameter x 3" Long
07 - Two Loose Angles, Shipped Unpainted and Separately for Field Installation
- 7. FINISH: (XX)**
01 - Mill
44 - British White

* Damper welded in sleeve.

1330

The medium/minimum security grille shall be a Krueger model 1330. The face of the security grille shall be constructed of 16 gage steel for the frame and 14 gage steel blades. The blades shall be set at 40° deflection and reinforced by a 14 gage mullion spaced no greater than 3" apart. A 10 gage x #2 steel wire mesh screen shall be placed behind the face in the sleeve of the security grille. The sleeve shall be 14 gage and stitch welded to the face of the medium/minimum security grille and along the entire length of the sleeve.

Optional front or rear operated steel opposed blade damper available.

Other options include two loose 1 1/2"x1 1/2"x3/16" steel angles, steel angle frame 1 1/2"x1 1/2"x3/16" welded at the corners, 3/4" diameter x 3" long steel anchor bars and 3/4" diameter steel security bars.

PERFORMANCE

The manufacturer shall provide published (printed or electronic) performance data for the diffuser. Performance data shall include 2 - 7 octave band sound power levels. The diffuser shall be tested in accordance to the data standards at the time of product introduction or ANSI/ASHRAE Standard 70.

FINISH

The paint finish shall be #44 British White and be an anodic acrylic paint, baked at 315°F for 30 minutes. The paint thickness shall be 0.8 – 1.0 mils, gloss at 60° per ASTM D523-89 of 50 – 85%, pencil hardness per ASTM D3363-92A of HB – H, crosshatch adhesion per ASTM D3359-83 of 4B – 5B, impact per ASTM D2794-93 of direct impact >100 in/lb and reverse impact >80 in/lb, salt spray per ASTM B117-9048 of 96 hours, humidity per ASTM D2247-92 of >500 hours and water soak per ASTM D870-92 of 250 hours.