

Fans & Blowers

# Twin City

Defining Innovation.



## BACKWARD INCLINED FANS

TYPE BC SWSI & DWDI

# BC SWSI & DWDI Backward Inclined Fans

This catalog features type BC non-overloading centrifugal fans in SWSI (single width, single inlet) and DWDI (double width, double inlet) design. BAE airfoil fans offer a slightly higher efficiency and less noise than BC fans at a price premium of about 2%. However, the hollow airfoil blades are more susceptible to erosion by particulate matter in the airstream than BC blades and thus type BAE is recommended for clean air applications only. Both designs are a popular choice for the efficient handling of large volumes of relatively clean air at low to moderate pressures in applications such as:

- HVAC (heating, ventilating and air conditioning)
- Combustion air supply
- Filtration and drying systems
- Fume hood and spray booth and other exhaust systems
- Air pollution control (clean side of dust collectors)
- Industrial processes

Please discuss your particular application with the Twin City Fan & Blower representative for your area.

Twin City Fan & Blower has established itself as a leader in the design and manufacture of quality air moving equipment and continues to advance by implementing a philosophy that stresses quality in all of its operations. Our products are known for their rugged construction and reliability of operation. Twin City Fan & Blower offers flexibility in design and construction of fans coupled with superior service before and after the sale.

Refer to Bulletin 370 for type BAE (airfoil wheel) SWSI and DWDI fans.

Refer to Bulletin 600 for Ventilating Sets featuring type BC (designated as BCV) and FC (FCV) fans in Arrangement 10. Refer to Bulletin 370 for type BAV (airfoil wheel) ventilation sets in Arrangement 10.



## Contents

Certification . . . . .	2
Introduction. . . . .	2
Construction Features . . . . .	3
Arrangements . . . . .	4
Optional Construction . . . . .	6
Standard Configurations . . . . .	8
Accessories. . . . .	9
Fan Selection Guidelines. . . . .	12
Maximum RPM, Wheel Weights & WR <sup>2</sup> . . . . .	13
Material Specifications & Weights . . . . .	14
Performance Data. . . . .	17
BC SWSI. . . . .	18
BC DWDI . . . . .	29
Dimensional Drawings . . . . .	36
Typical Specifications. . . . .	55

## Certification



Twin City Fan & Blower certifies that the SWSI Backward Inclined fans shown on pages 18 through 28 are licensed to bear the AMCA Seal. The ratings shown are based on tests and procedures performed in accordance with AMCA Publication 211 and AMCA Publication 311 and comply with the requirements of the AMCA Certified Ratings Program.



Twin City Fan & Blower certifies that the DWDI Backward Inclined fans shown on pages 29 through 35 are licensed to bear the AMCA Seal. The ratings shown are based on tests and procedures performed in accordance with AMCA Publication 211 and comply with the requirements of the AMCA Certified Ratings Program.

Refer to Bulletin 306 for sound power levels.

©2011 Twin City Fan Companies, Ltd. All rights reserved throughout the world.

Bulletin illustrations cover the general appearance of Twin City Fan & Blower products at the time of publication and we reserve the right to make changes in design and construction at any time without notice.

# Construction Features

## Wheel Construction

Type BC wheels are constructed of steel using flat single thickness blades, solid welded to the rim and backplate. The inlet-side rim is designed as a proper companion for the inlet cone.

Note that the use of a conical spun shroud (rim) makes BC fans less susceptible to the performance losses associated with poor inlet conditions. All BC wheels are statically and dynamically balanced to grade BV3 per AMCA 204 for smooth operation prior to being assembled in the fan, followed by final balance of the entire rotating assembly.

## Housing Construction

All fan housings are continuously welded to provide strength and durability for extended service life — a necessity in all commercial and industrial installations.

All SWSI fans and DWDI Class III and IV fans feature an outlet flange for duct connection as standard. DWDI Class I and II fan outlets are designed for slip-joint connection. A flanged outlet is available as an option. Inlet collars for slip-joint connections are standard on all SWSI fans. Lifting lugs are standard on all fans. All housings are reinforced with rigid bracing to increase structural integrity. The support angles are intermittently welded and caulked between welds to prevent bleed-through corrosion. Precisely positioned cutoff plates and aerodynamically spun inlet cones provide high efficiency and smooth airflow through the fan.

All fans are available in standard discharge configuration (see page 8). SWSI fans Class I and II, sizes 270 and smaller in Arrangements 1, 4, 9 and 10 are field rotatable to any standard discharge position. To help reduce overall heights, all DWDI fans feature a non-rotatable housing design as standard.

## Shaft

Shafts are AISI Grade 1040 or 1045 hot-rolled steel accurately turned, ground, polished, and ring gauged for accuracy. Shafts are generously sized for a first critical speed of at least 1.43 times the maximum speed for the class.

## Bearings

Bearings are heavy duty, grease lubricated, spherical roller or adapter mounted anti-friction ball, self-aligning, pillow block type, selected for minimum average bearing life (AFBMA L-50) in excess of 200,000 hours at the maximum fan RPM.

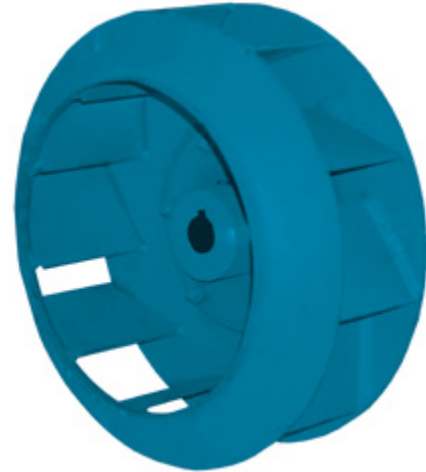

*BC SWSI wheel*

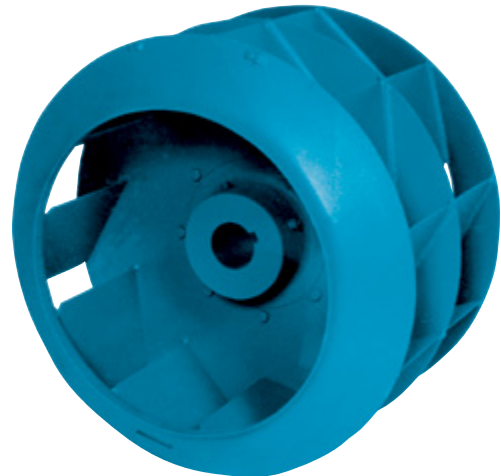

*BC DWDI wheel*

## Mechanical Run Test & Final Vibration Check

All fans are assembled for a mechanical run test and final balance prior to shipment. Vibration readings are taken on both fan bearings in the axial, horizontal, and vertical directions at the specified speed. Fans are balanced to 0.15 in./sec. peak or less.

# SWSI Arrangements



Arrangement 1 fan with optional unitary base, horizontal split housing, shaft and V-belt drive guard.

## Arrangement 1 SWSI — Single Width, Single Inlet

Arrangement 1 fans are usually belt driven. The wheel is overhung on the shaft, i.e., mounted at the end of the shaft. The motor can be mounted in any of the four AMCA standard motor positions, W, X, Y, or Z. The two fan bearings are mounted on the bearing pedestal, out of the airstream. Arrangement 1 fans are thus recommended for high temperature or contaminated air applications. Belt driven configurations offer performance flexibility. If the performance requirements change after the fan has been installed, it is simple and inexpensive to change the drive.

Extended lube line at inlet — standard on all Arrangement 3 fans.



## Arrangement 3 SWSI — Single Width, Single Inlet

Arrangement 3 is available in belt driven only. Arrangement 3 SWSI has one bearing located in the airstream. The wheel is mounted between the bearings and supported by the fan housing, which makes it a structurally sound, compact, and economical arrangement.

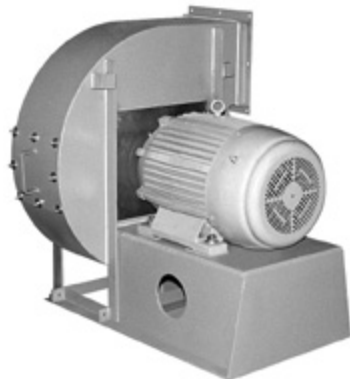

Direct drive Arrangement 4 with bolted access door and shaft seal.

## Arrangement 4 SWSI — Single Width, Single Inlet

Arrangement 4 is available in direct drive only. The fan wheel is mounted directly on the motor shaft with the motor mounted on a pedestal. An Arrangement 4 design offers low maintenance as there are no fan bearings, fan shaft or drive parts to maintain. Arrangement 4 is typically limited to size 365 or smaller.

### Typical Direct Drive Speeds

60 Hz OPERATION		50 Hz OPERATION	
Synchronous Speed	Full Load Speed	Synchronous Speed	Full Load Speed
3600	3500	3000	2900
1800	1750	1500	1450
1200	1170	1000	975
900	870	750	725

The actual full load speed of the motor can vary slightly depending upon motor HP and motor design.

Arrangement 8 fan with optional coupling.

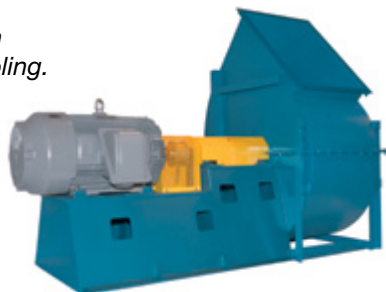

## Arrangement 8 SWSI — Single Width, Single Inlet

Arrangement 8 is a modified version of Arrangement 1 used for direct drive. The Arrangement 1 bearing pedestal is extended to accommodate the motor. A flexible coupling connects the fan and motor shaft. Refer to the typical direct drive speeds under Arrangement 4.

Recommended for 250 HP and larger applications.

# SWSI Arrangements

## Arrangement 9

### SWSI — Single Width, Single Inlet

Arrangement 9 is available as belt driven only. A motor slide base is mounted on the side of the bearing pedestal. This arrangement permits the unit to ship as a complete assembly with the motor and drive mounted. Typically, the motor is mounted on the left side of the pedestal for CW rotation fans and on the right side for CCW rotation fans.

## Arrangement 9F

### SWSI — Single Width, Single Inlet (Not Shown)

Arrangement 9F is available when a unit requires a motor that is too large to mount on the side of the bearing pedestal. The fan base is extended to accommodate the motor, for horizontal mounting, similar to an Arrangement 1 fan. Typically, the motor is mounted on the left side of the pedestal for CW rotation fans and on the right side for CCW rotation fans. Arrangement 9F is not suitable for mounting vibration isolators directly under the fan.



*Fan shown is Arrangement 9 CW-THD with non-standard motor location on right-hand side.*

## Arrangement 10

### SWSI — Single Width, Single Inlet

Arrangement 10 is available as belt driven only. For Class I and II fans, sizes 122 through 365, Arrangement 10 units are commonly referred to as Ventilating Sets. (Refer to Bulletin 600 for more details.) An Arrangement 10 unit has an adjustable motor base mounted inside the bearing pedestal. This arrangement offers a more compact design than the Arrangement 9 and is suitable for roof or outdoor installations with a weather cover.



*Class II Arrangement 10 ventilating set with optional shaft cooler and insulated heat shield.*

# DWDI Arrangements

## Arrangement 3

DWDI fans are generally supplied in Arr. 3 for V-belt drive. The wheel is mounted between the bearings and supported by the fan housing. Since both bearings are located in the airstream, standard DWDI fans should be used for clean air applications with air temperatures limited to 130°F. The motor can be mounted in any of the four standard motor positions: W, X, Y or Z.

## Arrangement 3F

Arr. 3F offers an integral extended base to accommodate the motor. The base is prepunched to accept vibration isolators. Arr. 3F is available to Size 660 and for motor positions W and Z as standard. For motor positions X and Y, consult factory.

*Arr. 3F with motor located in "Z" position.*

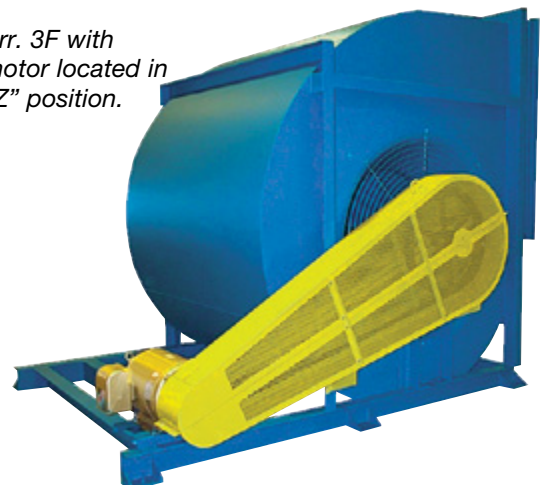

# Optional Construction

## Spark Resistant Construction

Fan applications may involve the handling of potentially explosive or flammable particles, fumes or vapors. Such applications require careful consideration by the system designer to insure the safe handling of such gases. Twin City Fan & Blower offers the following classifications of spark resistant construction per AMCA Standard 99-0401-86. It is the specifier or the user's responsibility to specify the type of spark resistant construction with full recognition of the potential hazards and the degree of protection required.

- Type A All parts of the fan in contact with the airstream must be made of non-ferrous material — usually aluminum and limited to 250°F operation.
- Type B The fan shall have a non-ferrous wheel and non-ferrous ring about the opening through which the shaft passes — usually aluminum wheel and rub ring and limited to 250°F construction.
- Type C The fan shall be so constructed that the shift of the wheel or shaft will not permit two ferrous parts of the fan to rub or strike. This is accomplished with an aluminum inlet cone and rub ring. This construction is limited to 500°F. Construction to 800°F is available using a steel inlet cone with copper/bronze lining.

### Notes:

1. Bearings shall be placed outside the airstream. Therefore, do not use Arrangement 3 or 7.
2. The user shall electrically ground all fan parts.

Refer to the above listed AMCA standard for full details

## Special Metals

To suit the demanding applications of today's industry, Twin City Fan & Blower offers a variety of material for construction, including aluminum and stainless steel. We offer AWS and ASME certified welding procedures and welding technicians to assure quality construction when using special metals as well.

## Split Housings

All fans are designed to permit wheel removal through the fan inlet. To suit installation as well as transportation requirements, Twin City Fan & Blower offers horizontal split, pie-shaped, as well as other special split housing designs. Pie-shaped split housings allow fan wheel and shaft removal without disconnecting ductwork.

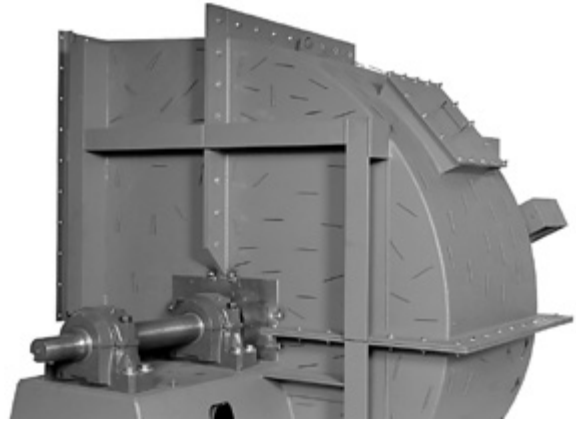

*Fan with pie-shaped split housing, raised access door and insulation pins.*

## Swingout Construction

Swingout fans are ideal for applications requiring frequent cleaning and inspection of the fan wheel and interior of the housing such as found in spray painting booth exhaust. Refer to Bulletin GA200 for other types of easy access fans offered by Twin City Fan & Blower.

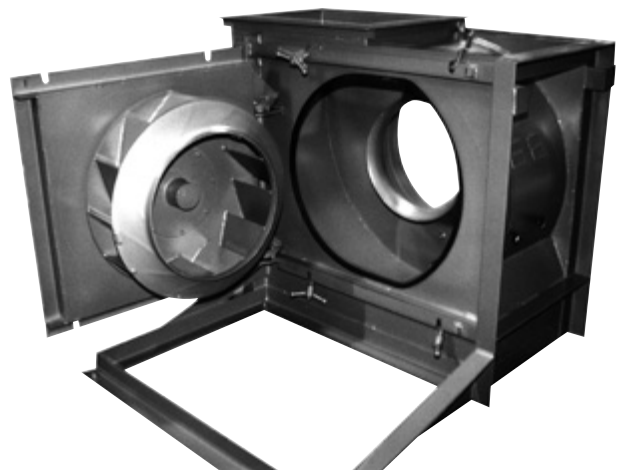

# Optional Construction

## High Temperature Modifications

### Construction

Standard fan design options are available to handle airstream temperatures to 800°F. Consult your Twin City Fan & Blower representative for applications over 800°F. The fan bearings should be kept outside of the hot airstream and below 130°F ambient. High temperature operating limits, available arrangements, and necessary modifications are shown in Table 1.



Shaft Cooler and Shaft Seal

Table 1. High Temperature Construction Requirements

TEMPERATURE (°F)	TYPE OF BEARING	LUBRICATION	OTHER REQUIREMENTS	AVAILABLE ARRANGEMENTS
-20°F To +300°F	Ball or Roller	Grease	Standard Fan	Arr. 1, 8, 9, 9F, 10 Arr. 3 and 3F to 130°F Arr. 4 to 180°F
300°F To 500°F	Ball or Roller with (1) Expansion Bearing	High Temp. Grease	Shaft Cooler, Shaft Seal. For Arr. 9 & 10 Fans, a Motor Heat Shield is Included.	Arr. 1, 8, 9, 9F, 10
500°F To 800°F	Ball or Roller with (1) Expansion Bearing	High Temp. Grease	High Temp. Aluminum Paint Shaft Cooler, Shaft Seal. For Arr. 9 & 10 Fans, a Motor Heat Shield is Included.	Arr. 1, 8, 9, 9F, 10 (Arr. 9 & 10 Limited to 600°F)

### Derating Factors For High Temperature

Fan operation at high temperature adversely affects the strength of fan wheels. As a result, the maximum safe speed must be derated by the factors shown in Table 2.

**Example:** Maximum safe speed at 600°F for a size 365 BC, SWSI, Class II steel wheel = 0.86 x 1283 = 1103 RPM (1283 RPM is maximum RPM at 70°F).

Table 2. Derating Factors For High Temperature

TEMPERATURE (°F)	STANDARD STEEL	STAINLESS STEEL
70	1.00	1.00
200	0.99	0.95
250	0.98	0.93
300	0.98	0.91
400	0.96	0.88
500	0.93	0.84
600	0.90	0.81
700	0.80	0.78
800	0.60	0.75
900	—	0.73
1000	—	0.70

# Standard Configurations

## Designation for Rotation and Discharge

Direction of rotation is determined from drive side of the fan.  
 On single inlet fans, the drive side is always considered the side opposite the fan inlet.  
 On double inlet fans with drives on both sides, the drive side is that with the higher power drive unit.  
 The direction of discharge is determined in accordance with the diagrams shown above. The angle of discharge references the vertical axis of the fan and is designated in degrees above or below that reference axis.  
 On fans inverted for ceiling suspension or side-wall mounting, the discharge is determined when the fan is resting on the floor.

## Motor Positions

The drawing above illustrates the AMCA motor position standards for Arrangement 1 and 3 fans (Arrangement 1 shown). The location of the motor is determined by facing the drive side of the fan and designating the motor position by letters W, X, Y, or Z, in accordance with the diagram shown above.

Illustrations reprinted from AMCA Publication 99 Standards Handbook, with the express written permission from the Air Movement and Control Association International, Inc., 30 West University Drive, Arlington Heights, IL 60004-1983.



# Accessories

## Volume Control Devices

Outlet dampers, variable inlet vanes, and variable frequency drives are three popular devices used to control volume for fan systems.

### Outlet Dampers

The closing of the damper adds to the resistance that the fan is working against. This moves the operating point to the left of the initial rating point. The savings in horsepower depends on the relative position on the fan curve and is usually much less than offered by other methods. Outlet dampers are typically the least expensive option and should be considered when

infrequent operation at lesser capacity is desired or when handling hot, humid or particulate laden air.

There are two types of outlet dampers: parallel blade and opposed blade.

Parallel blade dampers are recommended for systems where air volume is modulated between full-open to about 75% of open.

Opposed blade dampers cost about 10% more and are recommended for systems where volume is modulated over the entire range. Opposed blades reduce air volume in a closer relationship to the control arm movement.

### Variable Inlet Vanes

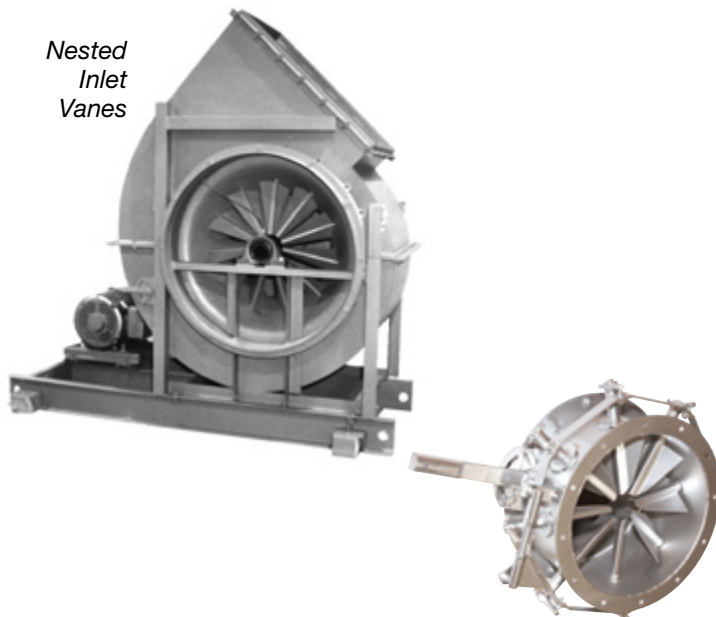

External Inlet Vanes

Variable inlet vanes cause the entering air to spin in the direction of wheel rotation, resulting in reduction in volume, static pressure and brake horsepower and thus providing an infinite number of fan curves approximately parallel to the original fan curve. Variable inlet vanes cost about 50% to 80% more than outlet dampers but offer significant savings in energy. Because of their simplicity, inlet vanes can be more reliable when compared to variable frequency drives.

There are two types of variable inlet vanes: nested (internal type) and bolted on (external type).

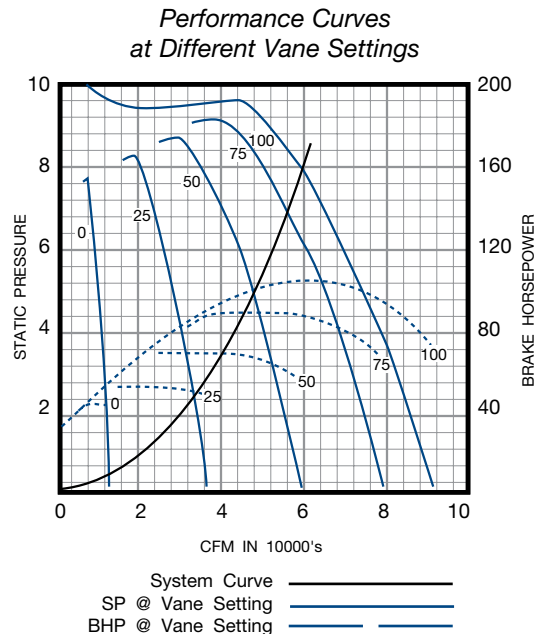

**Nested inlet vanes** are built into the fan inlet cone and offer the advantage of saving space and lower cost as opposed to the external type, and they will be provided on all fan sizes 165 and larger. Twin City Fan & Blower offers cantilevered vanes to size 730 Class II fans to minimize insertion losses and noise associated with center hub design.

**External inlet vanes** are bolted to the inlet of the fan and are available as standard to size 150. Use of external vanes should be considered for hostile environments since operating linkages are shielded from the airstream. Both types of inlet vanes are available to 600°F construction.

### Variable Frequency Drive (VFD) Fan Motors

VFD changes the fan speed and can provide the greatest potential for energy savings, although at highest initial cost. VFD should be considered for

extended operation at part load conditions, especially below 70% of the full volume operation.

# Accessories

## Access Doors

Bolted, quick opening, and raised bolted access doors are available for wheel inspection or maintenance.

## Drain

Threaded pipe coupling welded to the lowest point in the housing scroll. All fans come with a weep hole in the bottom of the housing.

## Shaft Seal

A shaft seal reduces leakage and protects the bearings from a contaminated airstream. It is constructed of non-asbestos woven fibrous materials (ceramic felt) compressed between an aluminum cover plate and the fan housing. A ceramic felt shaft seal does not make the fan gas tight. A variety of special seals is available for low leakage applications requiring more positive protection, including mechanical type stuffing boxes. (The picture on page 7 shows a standard seal.)

## Shaft Cooler or Heat Slinger

A cast aluminum shaft cooler is recommended to dissipate the heat and protect the fan bearings for all applications over 300°F. (Refer to picture on page 7.)

## Flanged Inlet

A punched inlet flange is available for duct mounting.

## Flanged Outlet (DWDI Class I & II)

A punched or unpunched flange is welded to the fan outlet. An unpunched flanged outlet is standard on all SWSI and DWDI Class III and IV fans.

## Inlet/Outlet Companion Flanges

Companion flanges are used for installing the fan to flexible sleeve connections and are punched to match the fan's inlet or outlet.

## Inlet and Outlet Screens

Safety screens are available for mounting in the fan inlet or outlet in non-ducted applications.



*Bolted  
Access Door*



*Quick-Opening  
Access Door*



*Raised Bolted  
Access Door*



*Companion  
Inlet Flange*

# Accessories

## Belt Guards

A belt guard protects personnel from the moving drive parts. Both standard and totally enclosed type guards are available.

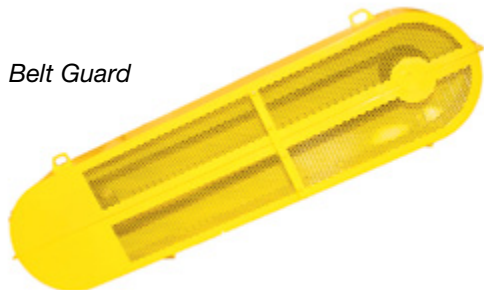

*Belt Guard*

## Shaft and Bearing Guards (sWSI)

Solid sheet metal guards cover shaft and bearings and come with extended lube lines to a common point out either side of the guard. A guard spanning the shaft between the bearings is also available to provide easy access to bearings for lubrication and vibration monitoring.

## Unitary Base

A structural steel base provides common support to fan, motor and drive including guards. This style of base is designed for use without isolators and requires adequate foundation integrity for proper operation.

## Vibration Isolation Bases

Heavy structural base for fan, motor and drive is designed for use with spring or rubber-in-shear type isolators. Use of flexible connectors at inlet and outlet is required on fans with isolators.

## V-Belt Drives

V-belt drives offer an economical yet flexible means of transmitting power to the fans. There are two types of V-belt drives.

- **Adjustable Pitch or Variable Speed Drives**  
An adjustable pitch drive offers easy adjustment of speed. The motor pulley pitch can be adjusted when the fan is at rest which can offer speed variation of about 10% from the design speed. This style of sheave can result in higher vibration so adjustable pitch drives are not recommended for use on motors over 10 HP or wherever low vibration is required.
- **Fixed Pitch or Constant Speed Drives**  
This type of drive offers low cost and lowest vibration levels. Speed change can often be accomplished by changing only one of the sheaves.

## Special Paint & Protective Coatings

Twin City Fan & Blower has an in-house, specialty coating facility to handle any type of coating requirement. Refer to Engineering Supplement ES-35 for more details.

## Bearing Upgrades

Unit roller or split pillow block, double row roller bearings are available. Split pillow block roller bearings are not available for fans with less than 1<sup>7</sup>/<sub>16</sub>" diameter bearings and are not recommended for fans with light loadings. Refer to Engineering Data ED-1200 and ED-1300 for the correct type of bearings, selection criteria, maintenance, etc.

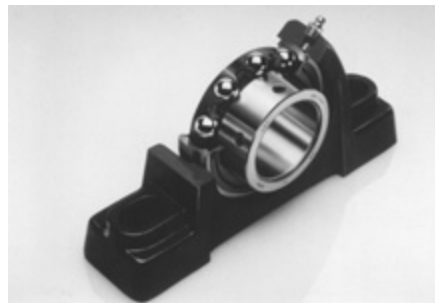

*Ball Bearing*

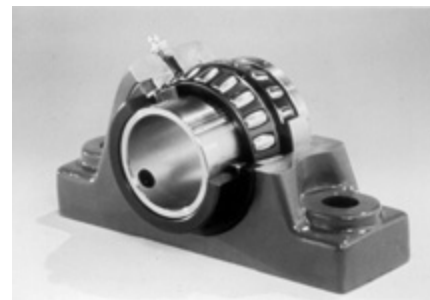

*Unit Roller Bearing*

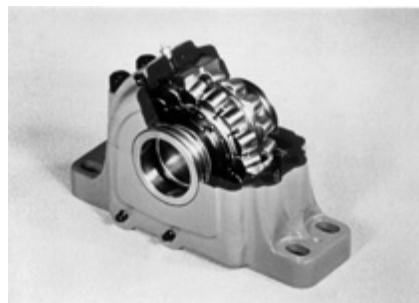

*Split Pillow Block Bearing*

## Other Accessories Available

- Variation in wheel diameter and width
- Inlet boxes
- Bearings RTD
- Piezometer ring airflow measuring system (see page 12)
- Consult factory for other accessories

# Flow Measurement System

## Piezometer Ring (Airflow Measuring System)

A piezometer ring is available on model BC fans, as well as other Twin City Fan housed and plenum fans, as part of an airflow measuring system, based on the principle of a flow nozzle. The inlet cone of the fan is used as the flow nozzle. The flow can be calculated by measuring the pressure drop through the inlet cone. No tubes or sensors are inserted in the high velocity airstream which could obstruct airflow.

The system, consists of a piezometer ring mounted at the throat and a static pressure tap mounted on the face of the inlet cone. A differential pressure transducer and digital display can also be provided.

The pressure drop is measured from the tap located on the face of the inlet cone to the piezometer ring in the throat. The inlet tap is connected to the high-pressure side of the transducer and the piezometer ring is connected to the low-pressure side.

Based on Twin City Fan laboratory tests, the system was determined to be accurate within +/-5%.

Refer to Twin City Fan Engineering Supplement ES-105.

**NOTE: Twin City Fan does not recommend placement of flow measuring probes inside the fan inlet cone in the path of airflow. These devices create disturbances and unpredictable performance losses. Twin City Fan will not be responsible for loss of performance due to such devices.**

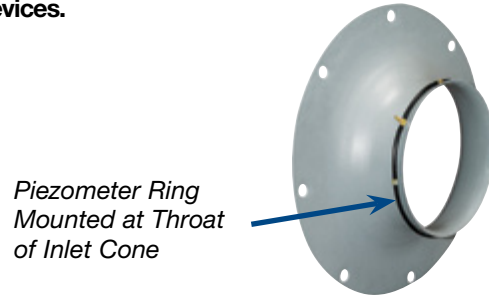

## Fan Selection Guidelines

The performance tables in this catalog are based on fans handling standard air at a density of 0.075 pounds per cubic foot. This is equivalent to air at 70°F at sea level (29.92" Hg barometric pressure). When specified performance is at a density dif-

ferent than standard, it must be converted to the equivalent standard conditions before the fan can be selected from the performance tables. The equivalent standard conditions can be calculated by using the Temperature and Altitude Density Ratios shown in Table 3.

Table 3. Temperature and Altitude Density Ratios

AIR TEMP °F	ALTITUDE IN FEET ABOVE SEA LEVEL											
	0	1000	2000	3000	4000	5000	6000	7000	8000	9000	10000	15000
	BAROMETRIC PRESSURE IN INCHES OF MERCURY											
	29.92	28.86	27.82	26.82	25.84	24.90	23.98	23.09	22.22	21.39	20.58	16.89
-50	1.293	1.247	1.201	1.159	1.116	1.076	1.036	0.997	0.960	0.924	0.889	0.729
0	1.152	1.111	1.071	1.032	0.995	0.959	0.923	0.889	0.856	0.824	0.792	0.650
50	1.039	1.003	0.967	0.932	0.897	0.864	0.833	0.801	0.772	0.743	0.715	0.586
70	1.000	0.964	0.930	0.896	0.864	0.832	0.801	0.772	0.743	0.714	0.688	0.564
100	0.946	0.912	0.880	0.848	0.818	0.787	0.758	0.730	0.703	0.676	0.651	0.534
150	0.869	0.838	0.808	0.770	0.751	0.723	0.696	0.671	0.646	0.620	0.598	0.490
200	0.803	0.774	0.747	0.720	0.694	0.668	0.643	0.620	0.596	0.573	0.552	0.453
250	0.747	0.720	0.694	0.669	0.645	0.622	0.598	0.576	0.555	0.533	0.514	0.421
300	0.697	0.672	0.648	0.624	0.604	0.580	0.558	0.538	0.518	0.498	0.480	0.393
350	0.654	0.631	0.608	0.586	0.565	0.544	0.524	0.505	0.486	0.467	0.450	0.369
400	0.616	0.594	0.573	0.552	0.532	0.513	0.493	0.476	0.458	0.440	0.424	0.347
450	0.582	0.561	0.542	0.522	0.503	0.484	0.466	0.449	0.433	0.416	0.401	0.328
500	0.552	0.532	0.513	0.495	0.477	0.459	0.442	0.426	0.410	0.394	0.380	0.311
550	0.525	0.506	0.488	0.470	0.454	0.437	0.421	0.405	0.390	0.375	0.361	0.296
600	0.500	0.482	0.465	0.448	0.432	0.416	0.400	0.386	0.372	0.352	0.344	0.282
650	0.477	0.460	0.444	0.427	0.412	0.397	0.382	0.368	0.354	0.341	0.328	0.269
700	0.457	0.441	0.425	0.410	0.395	0.380	0.366	0.353	0.340	0.326	0.315	0.258
750	0.439	0.423	0.407	0.393	0.379	0.365	0.351	0.338	0.326	0.313	0.303	0.248
800	0.420	0.404	0.389	0.375	0.362	0.350	0.336	0.323	0.311	0.300	0.290	0.237
850	0.404	0.391	0.376	0.363	0.349	0.336	0.324	0.312	0.300	0.289	0.279	0.228
900	0.389	0.376	0.363	0.349	0.336	0.324	0.312	0.300	0.289	0.279	0.268	0.220
950	0.376	0.363	0.350	0.337	0.325	0.313	0.301	0.290	0.279	0.269	0.259	0.212
1000	0.363	0.350	0.338	0.325	0.314	0.302	0.291	0.280	0.270	0.259	0.250	0.205

## Example

Assume a 365 BC SWSI fan to handle 15,500 CFM, 2.5" SP, at 300°F and 3000 ft altitude.

1. For the operating conditions of 300°F and 3000 ft altitude, the factor can be found in Table 3 to be 0.624.
2. Divide the operating SP by this factor. Thus, 2.5" ÷ 0.624 = 4" SP, which is the equivalent static pressure at standard air density.

3. From the 365 BC SWSI performance table find the fan RPM and BHP for 15,500 CFM and 4" SP to be 893 RPM and 12.86 BHP (by interpolation) at standard conditions. 12.86 BHP is also referred to as "cold" or "starting" brake horsepower.

To determine the BHP at operating conditions, multiply the BHP at standard conditions by the factor from Table 3 (12.86 x 0.624 = 8.04 BHP). The BHP at operating conditions is 8.04 BHP.

# Maximum RPM, Wheel Weights & WR<sup>2</sup> (moment of inertia in lb-ft<sup>2</sup>)

## BC SWSI

FAN SIZE	CLASS I			CLASS II			CLASS III			CLASS IV		
	MAX. RPM	WHEEL WEIGHT (LB)	WR <sup>2</sup> (LB-FT <sup>2</sup> )	MAX. RPM	WHEEL WEIGHT (LB)	WR <sup>2</sup> (LB-FT <sup>2</sup> )	MAX. RPM	WHEEL WEIGHT (LB)	WR <sup>2</sup> (LB-FT <sup>2</sup> )	MAX. RPM	WHEEL WEIGHT (LB)	WR <sup>2</sup> (LB-FT <sup>2</sup> )
122	3167	15	1.7	4119	15	1.7	5208	22	2.4	5608	25	2.7
135	2874	17	2.4	3738	18	2.7	4726	27	3.9	5099	28	3.9
150	2587	20	3.7	3364	21	4.1	4253	31	5.8	4580	33	5.8
165	2352	24	5.7	3058	28	7.0	3867	38	8.4	4167	37	8.4
182	2118	31	8.8	2729	39	10.8	3473	53	13.9	3766	53	13.9
200	1932	38	12.5	2490	49	17.4	3169	63	19.8	3442	75	25.3
222	1737	66	23.6	2238	74	28.8	2848	85	32.0	3088	98	40.3
245	1577	81	38.3	2033	87	42.9	2587	110	50.9	2808	130	66.8
270	1397	94	56.4	1803	103	64.6	2287	132	79.2	2544	152	97.8
300	1257	113	88.8	1623	125	101	2059	172	139	2291	172	136
330	1143	151	149	1475	167	158	1871	215	221	2081	205	200
365	995	198	245	1283	214	260	1727	273	288	1883	252	297
402	903	244	361	1163	254	382	1566	301	437	1706	298	437
445	817	340	566	1052	392	692	1416	412	681	1545	446	776
490	742	393	816	956	455	1001	1286	478	985	1401	550	1195
542	670	461	1209	863	542	1392	1162	604	1570	1260	731	1994
600	606	593	1954	780	642	2066	1050	793	2647	1146	907	3141
660	551	859	3008	710	975	3629	955	1068	4034	1040	1250	4961
730	498	1147	5336	641	1142	5336	863	1274	6160	940	1567	7724
807	450	1391	8228	580	1466	8754	780	1711	10416	851	1980	12378
890	408	1902	13450	526	1908	13451	708	2378	17378	772	2679	20204
982	370	2243	19589	477	2257	19590	641	2777	26316	CONSULT FACTORY		

## BC DWDI

FAN SIZE	CLASS I			CLASS II			CLASS III			CLASS IV		
	MAX. RPM	WHEEL WEIGHT (LB)	WR <sup>2</sup> (LB-FT <sup>2</sup> )	MAX. RPM	WHEEL WEIGHT (LB)	WR <sup>2</sup> (LB-FT <sup>2</sup> )	MAX. RPM	WHEEL WEIGHT (LB)	WR <sup>2</sup> (LB-FT <sup>2</sup> )	MAX. RPM	WHEEL WEIGHT (LB)	WR <sup>2</sup> (LB-FT <sup>2</sup> )
122	3196	20.4	2.7	4168	22.1	2.7	CONSULT* FACTORY			CONSULT* FACTORY		
135	2904	23.7	3.9	3787	32.7	4.5						
150	2594	29.8	5.9	3383	37.7	6.8						
165	2358	37.1	9.3	3075	47.5	11.3						
182	2149	53.2	14.3	2776	59.7	17.2	3504	79.6	23.1	3766	88.1	23.4
200	1961	60.7	20.4	2533	91.3	29.0	3197	100	33.3	3442	122	42.2
222	1762	85.6	35.1	2277	108	45.7	2874	134	52.7	3088	163	66.4
245	1601	119	60.5	2068	130	69.7	2610	164	81.1	2808	217	110
270	1392	140	90.5	1830	172	108	2267	205	129	2544	252	170
300	1253	172	145	1647	208	171	2040	277	234	2290	297	235
330	1139	253	251	1497	275	270	1855	348	378	2081	339	343
365	1015	315	397	1302	342	426	1651	442	581	1883	398	510
402	920	370	585	1181	403	627	1497	460	750	1706	485	753
445	832	558	914	1068	656	1165	1354	635	1152	1545	726	1345
490	748	642	1321	966	763	1690	1222	728	1674	1401	874	2027
542	676	743	1960	872	819	2363	1104	919	2606	1260	1097	3239
600	611	912	3070	789	961	3513	998	1232	4506	1146	1392	5174
660	555	1194	4646	717	1420	6213	907	1606	6760	1040	1918	8291
730	502	1738	9198	648	1752	9201	820	1910	10010	940	2320	13075
807	459	2178	14334	589	2276	14866	746	2729	18438	851	3051	21302
890	416	3085	22490	534	3040	22484	677	3625	29218	772	3949	33373
982	377	3580	32972	484	3528	32965	CONSULT FACTORY			CONSULT FACTORY		

\* Operating speeds above 4000 RPM are not recommended. Consult factory.

# Material Specifications & Weights

## BC SWSI Class I

SIZE	HOUSING		SHAFT DIAMETER & BEARINGS				BARE FAN WEIGHT (LB)		
	SIDES	SCROLL	ARR 1 & 9		ARR 3		ARR 1	ARR 3	ARR 9
			SHAFT DIA.	BEARING TYPE	SHAFT DIA.	BEARING TYPE			
122	14	14	1	B	1	B	118	100	124
135	14	14	1	B	1	B	135	120	142
150	14	14	1	B	1	B	163	143	171
165	14	14	1	B	1	B	192	192	201
182	14	14	1 <sup>3</sup> / <sub>16</sub>	B	1 <sup>3</sup> / <sub>16</sub>	B	245	211	257
200	14	14	1 <sup>7</sup> / <sub>16</sub>	B	1 <sup>7</sup> / <sub>16</sub>	B	296	239	311
222	12	14	1 <sup>7</sup> / <sub>16</sub>	B	1 <sup>7</sup> / <sub>16</sub>	B	387	278	406
245	12	14	1 <sup>7</sup> / <sub>16</sub>	B	1 <sup>7</sup> / <sub>16</sub>	B	467	338	490
270	12	14	1 <sup>11</sup> / <sub>16</sub>	B	1 <sup>7</sup> / <sub>16</sub>	B	563	419	591
300	10	12	1 <sup>15</sup> / <sub>16</sub>	B	1 <sup>11</sup> / <sub>16</sub>	B	678	624	712
330	10	12	1 <sup>15</sup> / <sub>16</sub>	B	1 <sup>11</sup> / <sub>16</sub>	B	819	880	860
365	10	12	1 <sup>15</sup> / <sub>16</sub>	B	1 <sup>15</sup> / <sub>16</sub>	B	1009	948	1059
402	10	12	2 <sup>3</sup> / <sub>16</sub>	B	1 <sup>15</sup> / <sub>16</sub>	B	1339	1210	1406
445	10	12	2 <sup>7</sup> / <sub>16</sub>	B	1 <sup>15</sup> / <sub>16</sub>	B	1573	1530	1652
490	10	12	2 <sup>11</sup> / <sub>16</sub>	B	2 <sup>3</sup> / <sub>16</sub>	R	1834	1695	1925
542	10	12	2 <sup>15</sup> / <sub>16</sub>	B	2 <sup>7</sup> / <sub>16</sub>	R	2634	2190	2765
600	10	12	2 <sup>15</sup> / <sub>16</sub>	B	2 <sup>15</sup> / <sub>16</sub>	R	3124	3020	3281
660	10	12	3 <sup>7</sup> / <sub>16</sub>	R	2 <sup>15</sup> / <sub>16</sub>	R	4007	3850	4207
730	10	10	3 <sup>7</sup> / <sub>16</sub>	R	3 <sup>7</sup> / <sub>16</sub>	R	4962	4570	5210
807	10	10	3 <sup>15</sup> / <sub>16</sub>	R	3 <sup>15</sup> / <sub>16</sub>	R	5016	5250	5267
890	7	10	3 <sup>15</sup> / <sub>16</sub>	R	3 <sup>15</sup> / <sub>16</sub>	R	6831	6300	7173
982	7	7	4 <sup>15</sup> / <sub>16</sub>	SR	4 <sup>15</sup> / <sub>16</sub>	SR	8908	7390	9353

Bearing Types: B = Ball Bearing R = Unit Roller Bearings SR = Split Pillow Block Roller Bearings

## BC SWSI Class II

SIZE	HOUSING		SHAFT DIAMETER & BEARINGS				BARE FAN WEIGHT (LB)		
	SIDES	SCROLL	ARR 1 & 9		ARR 3		ARR 1	ARR 3	ARR 9
			SHAFT DIA.	BEARING TYPE	SHAFT DIA.	BEARING TYPE			
122	14	14	1	B	1	B	123	110	129
135	14	14	1	B	1	B	141	132	148
150	14	14	1 <sup>3</sup> / <sub>16</sub>	B	1 <sup>3</sup> / <sub>16</sub>	B	173	157	182
165	14	14	1 <sup>3</sup> / <sub>16</sub>	B	1 <sup>3</sup> / <sub>16</sub>	B	203	211	213
182	14	14	1 <sup>7</sup> / <sub>16</sub>	B	1 <sup>7</sup> / <sub>16</sub>	B	261	232	274
200	14	14	1 <sup>7</sup> / <sub>16</sub>	B	1 <sup>7</sup> / <sub>16</sub>	B	307	263	322
222	12	14	1 <sup>7</sup> / <sub>16</sub>	B	1 <sup>7</sup> / <sub>16</sub>	B	396	306	416
245	12	14	1 <sup>11</sup> / <sub>16</sub>	B	1 <sup>11</sup> / <sub>16</sub>	B	489	372	513
270	12	14	1 <sup>11</sup> / <sub>16</sub>	B	1 <sup>11</sup> / <sub>16</sub>	B	577	461	605
300	10	12	1 <sup>15</sup> / <sub>16</sub>	B	1 <sup>15</sup> / <sub>16</sub>	B	693	686	728
330	10	12	2 <sup>3</sup> / <sub>16</sub>	B	2 <sup>3</sup> / <sub>16</sub>	B	855	968	898
365	10	12	2 <sup>7</sup> / <sub>16</sub>	B	2 <sup>7</sup> / <sub>16</sub>	B	1080	1043	1134
402	10	12	2 <sup>7</sup> / <sub>16</sub>	R	2 <sup>7</sup> / <sub>16</sub>	B	1395	1331	1465
445	10	12	2 <sup>11</sup> / <sub>16</sub>	R	2 <sup>11</sup> / <sub>16</sub>	R	1640	1683	1722
490	10	12	2 <sup>15</sup> / <sub>16</sub>	R	2 <sup>11</sup> / <sub>16</sub>	R	1914	1865	2009
542	10	12	3 <sup>7</sup> / <sub>16</sub>	R	2 <sup>15</sup> / <sub>16</sub>	R	2762	2409	2900
600	10	12	3 <sup>7</sup> / <sub>16</sub>	R	3 <sup>7</sup> / <sub>16</sub>	R	3237	3322	3399
660	10	12	3 <sup>15</sup> / <sub>16</sub>	R	3 <sup>15</sup> / <sub>16</sub>	R	4204	4235	4415
730	10	10	3 <sup>15</sup> / <sub>16</sub>	R	3 <sup>15</sup> / <sub>16</sub>	R	5133	5027	5390
807	10	10	4 <sup>7</sup> / <sub>16</sub>	SR	4 <sup>7</sup> / <sub>16</sub>	SR	5238	5775	5500
890	7	10	4 <sup>15</sup> / <sub>16</sub>	SR	4 <sup>15</sup> / <sub>16</sub>	SR	7196	6930	7556
982	7	7	5 <sup>7</sup> / <sub>16</sub>	SR	5 <sup>7</sup> / <sub>16</sub>	SR	9138	8128	9594

Bearing Types: B = Ball Bearing R = Unit Roller Bearings SR = Split Pillow Block Roller Bearings

# Material Specifications & Weights

## BC SWSI Class III

SIZE	HOUSING		SHAFT DIAMETER & BEARINGS				BARE FAN WEIGHT (LB)		
	SIDES	SCROLL	ARR 1 & 9		ARR 3		ARR 1	ARR 3	ARR 9
			SHAFT DIA.	BEARING TYPE	SHAFT DIA.	BEARING TYPE			
122	10	10	1 <sup>7</sup> / <sub>16</sub>	B	1 <sup>7</sup> / <sub>16</sub>	B	139	195	146
135	10	10	1 <sup>7</sup> / <sub>16</sub>	B	1 <sup>7</sup> / <sub>16</sub>	B	159	223	167
150	10	10	1 <sup>11</sup> / <sub>16</sub>	B	1 <sup>11</sup> / <sub>16</sub>	B	198	276	208
165	10	10	1 <sup>11</sup> / <sub>16</sub>	B	1 <sup>11</sup> / <sub>16</sub>	B	224	363	236
182	10	10	1 <sup>11</sup> / <sub>16</sub>	B	1 <sup>11</sup> / <sub>16</sub>	B	293	394	308
200	10	10	1 <sup>15</sup> / <sub>16</sub>	B	1 <sup>11</sup> / <sub>16</sub>	B	343	433	360
222	10	10	1 <sup>15</sup> / <sub>16</sub>	B	1 <sup>15</sup> / <sub>16</sub>	R	442	477	465
245	7	7	2 <sup>3</sup> / <sub>16</sub>	B	1 <sup>15</sup> / <sub>16</sub>	R	620	539	651
270	7	7	2 <sup>3</sup> / <sub>16</sub>	B	1 <sup>15</sup> / <sub>16</sub>	R	740	639	777
300	7	7	2 <sup>7</sup> / <sub>16</sub>	R	2 <sup>3</sup> / <sub>16</sub>	R	950	1029	997
330	7	7	2 <sup>11</sup> / <sub>16</sub>	R	2 <sup>7</sup> / <sub>16</sub>	R	1157	1047	1215
365	7	7	2 <sup>11</sup> / <sub>16</sub>	R	2 <sup>7</sup> / <sub>16</sub>	R	1387	1448	1456
402	7	7	2 <sup>15</sup> / <sub>16</sub>	R	2 <sup>11</sup> / <sub>16</sub>	R	1719	1805	1805
445	7	7	3 <sup>7</sup> / <sub>16</sub>	R	2 <sup>15</sup> / <sub>16</sub>	R	2112	2237	2218
490	7	7	3 <sup>7</sup> / <sub>16</sub>	R	2 <sup>15</sup> / <sub>16</sub>	R	2478	2543	2602
542	7	7	3 <sup>15</sup> / <sub>16</sub>	R	3 <sup>7</sup> / <sub>16</sub>	R	3509	3245	3684
600	7	7	4 <sup>7</sup> / <sub>16</sub>	SR	3 <sup>15</sup> / <sub>16</sub>	R	4429	4437	4651
660	7	7	4 <sup>7</sup> / <sub>16</sub>	SR	3 <sup>15</sup> / <sub>16</sub>	R	5283	5922	5547
730	7	7	4 <sup>15</sup> / <sub>16</sub>	SR	4 <sup>7</sup> / <sub>16</sub>	SR	6365	6921	6683
807	7	7	4 <sup>15</sup> / <sub>16</sub>	SR	4 <sup>15</sup> / <sub>16</sub>	SR	6376	7986	6694
890	7	7	5 <sup>7</sup> / <sub>16</sub>	SR	5 <sup>7</sup> / <sub>16</sub>	SR	7662	9516	8045

Bearing Types: B = Ball Bearing R = Unit Roller Bearings SR = Split Pillow Block Roller Bearings

## BC SWSI Class IV

SIZE	HOUSING		SHAFT DIAMETER & BEARINGS				BARE FAN WEIGHT (LB)		
	SIDES	SCROLL	ARR 1 & 9		ARR 3		ARR 1	ARR 3	ARR 9
			SHAFT DIA.	BEARING TYPE	SHAFT DIA.	BEARING TYPE			
122	7	7	1 <sup>11</sup> / <sub>16</sub>	B	1 <sup>11</sup> / <sub>16</sub>	B	176	210	185
135	7	7	1 <sup>11</sup> / <sub>16</sub>	B	1 <sup>11</sup> / <sub>16</sub>	B	202	248	212
150	7	7	1 <sup>11</sup> / <sub>16</sub>	B	1 <sup>11</sup> / <sub>16</sub>	B	236	307	248
165	7	7	1 <sup>15</sup> / <sub>16</sub>	B	1 <sup>11</sup> / <sub>16</sub>	R	279	404	293
182	7	7	1 <sup>15</sup> / <sub>16</sub>	B	1 <sup>11</sup> / <sub>16</sub>	R	381	438	400
200	7	7	2 <sup>3</sup> / <sub>16</sub>	R	1 <sup>15</sup> / <sub>16</sub>	R	469	481	493
222	7	7	2 <sup>3</sup> / <sub>16</sub>	R	1 <sup>15</sup> / <sub>16</sub>	R	582	531	611
245	7	7	2 <sup>7</sup> / <sub>16</sub>	R	2 <sup>3</sup> / <sub>16</sub>	R	697	599	732
270	7	7	2 <sup>7</sup> / <sub>16</sub>	R	2 <sup>3</sup> / <sub>16</sub>	R	855	710	898
300	7	7	2 <sup>11</sup> / <sub>16</sub>	R	2 <sup>7</sup> / <sub>16</sub>	R	1079	1144	1133
330	0.25	0.25	2 <sup>15</sup> / <sub>16</sub>	R	2 <sup>11</sup> / <sub>16</sub>	R	1472	1556	1546
365	0.25	0.25	3 <sup>7</sup> / <sub>16</sub>	R	2 <sup>15</sup> / <sub>16</sub>	R	1903	1610	1998
402	0.25	0.25	3 <sup>7</sup> / <sub>16</sub>	R	2 <sup>15</sup> / <sub>16</sub>	R	2340	2006	2457
445	0.25	0.25	3 <sup>15</sup> / <sub>16</sub>	R	3 <sup>7</sup> / <sub>16</sub>	R	2925	2486	3071
490	0.25	0.25	3 <sup>15</sup> / <sub>16</sub>	R	3 <sup>7</sup> / <sub>16</sub>	R	3376	2825	3545
542	0.25	0.25	4 <sup>7</sup> / <sub>16</sub>	SR	3 <sup>15</sup> / <sub>16</sub>	R	4391	3607	4611
600	0.25	0.25	4 <sup>15</sup> / <sub>16</sub>	SR	4 <sup>7</sup> / <sub>16</sub>	SR	5301	4930	5566
660	0.25	0.25	4 <sup>15</sup> / <sub>16</sub>	SR	4 <sup>7</sup> / <sub>16</sub>	SR	6392	6581	6712
730	0.25	0.25	5 <sup>7</sup> / <sub>16</sub>	SR	4 <sup>15</sup> / <sub>16</sub>	SR	7874	7690	8268
807	0.25	0.25	5 <sup>7</sup> / <sub>16</sub>	SR	5 <sup>7</sup> / <sub>16</sub>	SR	7754	8874	8142
890	0.25	0.25	5 <sup>15</sup> / <sub>16</sub>	SR	5 <sup>15</sup> / <sub>16</sub>	SR	9198	10574	9658

Bearing Types: B = Ball Bearing R = Unit Roller Bearings SR = Split Pillow Block Roller Bearings

# Material Specifications & Weights

## BC DWDI Class I & II

SIZE	HOUSING		SHAFT DIAMETER & BEARINGS						BARE FAN WEIGHT (LB.)			
	SIDES	SCROLL	CLASS I			CLASS II			ARR. 3		ARR. 3F	
			SHAFT DIAMETER		BEARING TYPE	SHAFT DIAMETER		BEARING TYPE	CLASS I	CLASS II	CLASS I	CLASS II
			@ BRG.	@ WHEEL		@ BRG.	@ WHEEL					
122	14	14	1 <sup>3</sup> / <sub>16</sub>	1 <sup>3</sup> / <sub>16</sub>	B	1 <sup>7</sup> / <sub>16</sub>	1 <sup>7</sup> / <sub>16</sub>	B	139	153	181	199
135	14	14	1 <sup>3</sup> / <sub>16</sub>	1 <sup>3</sup> / <sub>16</sub>	B	1 <sup>11</sup> / <sub>16</sub>	1 <sup>11</sup> / <sub>16</sub>	B	159	174	207	226
150	14	14	1 <sup>7</sup> / <sub>16</sub>	1 <sup>7</sup> / <sub>16</sub>	B	1 <sup>11</sup> / <sub>16</sub>	1 <sup>11</sup> / <sub>16</sub>	B	193	212	251	276
165	14	14	1 <sup>7</sup> / <sub>16</sub>	1 <sup>7</sup> / <sub>16</sub>	B	1 <sup>15</sup> / <sub>16</sub>	1 <sup>15</sup> / <sub>16</sub>	B	222	244	289	317
182	12	14	1 <sup>11</sup> / <sub>16</sub>	1 <sup>11</sup> / <sub>16</sub>	B	1 <sup>15</sup> / <sub>16</sub>	1 <sup>15</sup> / <sub>16</sub>	B	248	273	322	355
200	12	14	1 <sup>11</sup> / <sub>16</sub>	1 <sup>11</sup> / <sub>16</sub>	B	2 <sup>3</sup> / <sub>16</sub>	2 <sup>3</sup> / <sub>16</sub>	B	344	378	447	491
222	12	14	1 <sup>15</sup> / <sub>16</sub>	1 <sup>15</sup> / <sub>16</sub>	B	2 <sup>7</sup> / <sub>16</sub>	2 <sup>7</sup> / <sub>16</sub>	B	451	496	586	645
245	12	14	2 <sup>3</sup> / <sub>16</sub>	2 <sup>3</sup> / <sub>16</sub>	B	2 <sup>7</sup> / <sub>16</sub>	2 <sup>7</sup> / <sub>16</sub>	B	509	560	662	728
270	12	14	2 <sup>3</sup> / <sub>16</sub>	2 <sup>3</sup> / <sub>16</sub>	B	2 <sup>11</sup> / <sub>16</sub>	2 <sup>11</sup> / <sub>16</sub>	R	639	703	831	914
300	10	12	2 <sup>7</sup> / <sub>16</sub>	2 <sup>7</sup> / <sub>16</sub>	B	2 <sup>7</sup> / <sub>16</sub>	2 <sup>15</sup> / <sub>16</sub>	R	895	985	1164	1281
330	10	12	2 <sup>7</sup> / <sub>16</sub>	2 <sup>7</sup> / <sub>16</sub>	B	2 <sup>7</sup> / <sub>16</sub>	3 <sup>7</sup> / <sub>16</sub>	R	1015	1117	1320	1452
365	10	12	2 <sup>11</sup> / <sub>16</sub>	2 <sup>11</sup> / <sub>16</sub>	B	2 <sup>11</sup> / <sub>16</sub>	3 <sup>7</sup> / <sub>16</sub>	R	1352	1487	1758	1933
402	10	12	2 <sup>7</sup> / <sub>16</sub>	2 <sup>15</sup> / <sub>16</sub>	R	2 <sup>11</sup> / <sub>16</sub>	3 <sup>7</sup> / <sub>16</sub>	R	1690	1859	2197	2417
445	10	12	2 <sup>7</sup> / <sub>16</sub>	3 <sup>7</sup> / <sub>16</sub>	R	2 <sup>15</sup> / <sub>16</sub>	3 <sup>15</sup> / <sub>16</sub>	R	2100	2310	2730	3003
490	10	12	2 <sup>11</sup> / <sub>16</sub>	3 <sup>7</sup> / <sub>16</sub>	R	3 <sup>7</sup> / <sub>16</sub>	3 <sup>15</sup> / <sub>16</sub>	R	2310	2541	3003	3303
542	10	12	2 <sup>15</sup> / <sub>16</sub>	3 <sup>15</sup> / <sub>16</sub>	R	3 <sup>7</sup> / <sub>16</sub>	4 <sup>7</sup> / <sub>16</sub>	R	2946	3241	3830	4213
600	10	12	3 <sup>7</sup> / <sub>16</sub>	4 <sup>7</sup> / <sub>16</sub>	R	3 <sup>15</sup> / <sub>16</sub>	4 <sup>15</sup> / <sub>16</sub>	R	4150	4565	—	—
660	10	12	3 <sup>7</sup> / <sub>16</sub>	4 <sup>7</sup> / <sub>16</sub>	R	3 <sup>15</sup> / <sub>16</sub>	4 <sup>15</sup> / <sub>16</sub>	R	5300	5830	—	—
730	10	10	3 <sup>15</sup> / <sub>16</sub>	4 <sup>15</sup> / <sub>16</sub>	R	3 <sup>15</sup> / <sub>16</sub>	5 <sup>15</sup> / <sub>16</sub>	R	6100	6710	—	—
807	10	10	3 <sup>15</sup> / <sub>16</sub>	5 <sup>7</sup> / <sub>16</sub>	R	4 <sup>7</sup> / <sub>16</sub>	6 <sup>7</sup> / <sub>16</sub>	SR	7580	8338	—	—
890	7	10	3 <sup>15</sup> / <sub>16</sub>	5 <sup>15</sup> / <sub>16</sub>	R	4 <sup>7</sup> / <sub>16</sub>	6 <sup>15</sup> / <sub>16</sub>	SR	9100	10010	—	—
982	7	7	4 <sup>15</sup> / <sub>16</sub>	6 <sup>7</sup> / <sub>16</sub>	SR	5 <sup>7</sup> / <sub>16</sub>	7 <sup>1</sup> / <sub>2</sub>	SR	11052	12157	—	—

Bearing Types: B = Ball Bearing R = Unit Roller Bearings SR = Split Pillow Block Roller Bearings

## BC DWDI Class III & IV

SIZE	HOUSING				SHAFT DIAMETER & BEARINGS						BARE FAN WEIGHT	
	CLASS III		CLASS IV		CLASS III			CLASS IV			ARR. 3	
	SIDES	SCROLL	SIDES	SCROLL	SHAFT DIAMETER		BEARING TYPE	SHAFT DIAMETER		BEARING TYPE	CLASS III	CLASS IV
					@ BRG.	@ WHEEL		@ BRG.	@ WHEEL			
122	CONSULT FACTORY		CONSULT FACTORY		CONSULT FACTORY			CONSULT FACTORY			CONSULT FACTORY	
135	CONSULT FACTORY		CONSULT FACTORY		CONSULT FACTORY			CONSULT FACTORY			CONSULT FACTORY	
150	CONSULT FACTORY		CONSULT FACTORY		CONSULT FACTORY			CONSULT FACTORY			CONSULT FACTORY	
165	CONSULT FACTORY		CONSULT FACTORY		CONSULT FACTORY			CONSULT FACTORY			CONSULT FACTORY	
182	10	10	7	7	2 <sup>3</sup> / <sub>16</sub>	2 <sup>3</sup> / <sub>16</sub>	R	2 <sup>7</sup> / <sub>16</sub>	2 <sup>7</sup> / <sub>16</sub>	R	464	516
200	10	10	7	7	2 <sup>7</sup> / <sub>16</sub>	2 <sup>7</sup> / <sub>16</sub>	R	2 <sup>3</sup> / <sub>16</sub>	2 <sup>15</sup> / <sub>16</sub>	SR	628	698
222	10	10	7	7	2 <sup>7</sup> / <sub>16</sub>	2 <sup>7</sup> / <sub>16</sub>	R	2 <sup>7</sup> / <sub>16</sub>	3 <sup>7</sup> / <sub>16</sub>	SR	801	892
245	7	7	7	7	2 <sup>7</sup> / <sub>16</sub>	2 <sup>15</sup> / <sub>16</sub>	R	2 <sup>11</sup> / <sub>16</sub>	3 <sup>15</sup> / <sub>16</sub>	SR	884	982
270	7	7	7	7	2 <sup>11</sup> / <sub>16</sub>	3 <sup>7</sup> / <sub>16</sub>	R	2 <sup>15</sup> / <sub>16</sub>	3 <sup>15</sup> / <sub>16</sub>	SR	1080	1200
300	7	7	7	7	2 <sup>11</sup> / <sub>16</sub>	3 <sup>7</sup> / <sub>16</sub>	R	2 <sup>15</sup> / <sub>16</sub>	4 <sup>7</sup> / <sub>16</sub>	SR	1473	1637
330	7	7	0.25	0.25	2 <sup>15</sup> / <sub>16</sub>	3 <sup>7</sup> / <sub>16</sub>	R	3 <sup>7</sup> / <sub>16</sub>	4 <sup>15</sup> / <sub>16</sub>	SR	1626	1807
365	7	7	0.25	0.25	2 <sup>15</sup> / <sub>16</sub>	3 <sup>15</sup> / <sub>16</sub>	R	3 <sup>7</sup> / <sub>16</sub>	4 <sup>15</sup> / <sub>16</sub>	SR	2043	2271
402	7	7	0.25	0.25	3 <sup>7</sup> / <sub>16</sub>	3 <sup>15</sup> / <sub>16</sub>	R	3 <sup>15</sup> / <sub>16</sub>	5 <sup>7</sup> / <sub>16</sub>	SR	2554	2838
445	7	7	0.25	0.25	3 <sup>7</sup> / <sub>16</sub>	4 <sup>7</sup> / <sub>16</sub>	R	3 <sup>15</sup> / <sub>16</sub>	5 <sup>7</sup> / <sub>16</sub>	SR	3175	3528
490	7	7	0.25	0.25	3 <sup>15</sup> / <sub>16</sub>	4 <sup>15</sup> / <sub>16</sub>	R	4 <sup>7</sup> / <sub>16</sub>	5 <sup>7</sup> / <sub>16</sub>	SR	3472	3858
542	7	7	0.25	0.25	3 <sup>15</sup> / <sub>16</sub>	5 <sup>7</sup> / <sub>16</sub>	R	4 <sup>7</sup> / <sub>16</sub>	5 <sup>15</sup> / <sub>16</sub>	SR	4400	4890
600	7	7	0.25	0.25	4 <sup>7</sup> / <sub>16</sub>	5 <sup>7</sup> / <sub>16</sub>	SR	4 <sup>15</sup> / <sub>16</sub>	6 <sup>7</sup> / <sub>16</sub>	SR	6189	6877
660	7	7	0.25	0.25	4 <sup>15</sup> / <sub>16</sub>	5 <sup>15</sup> / <sub>16</sub>	SR	5 <sup>7</sup> / <sub>16</sub>	6 <sup>7</sup> / <sub>16</sub>	SR	8108	9010
730	7	7	0.25	0.25	4 <sup>15</sup> / <sub>16</sub>	6 <sup>15</sup> / <sub>16</sub>	SR	5 <sup>15</sup> / <sub>16</sub>	7 <sup>1</sup> / <sub>2</sub>	SR	9333	10370
807	7	7	0.25	0.25	—	—	SR	—	—	SR	11597	12886
890	7	7	0.25	0.25	—	—	SR	—	—	SR	13922	15470
982	7	7	0.25	0.25	—	—	—	—	—	—	—	—

Bearing Types: B = Ball Bearing R = Unit Roller Bearings SR = Split Pillow Block Roller Bearings

SPECIFICATIONS SUBJECT TO CHANGE WITHOUT NOTICE.



# Performance Data

Typical BC SWSI Performance Curve

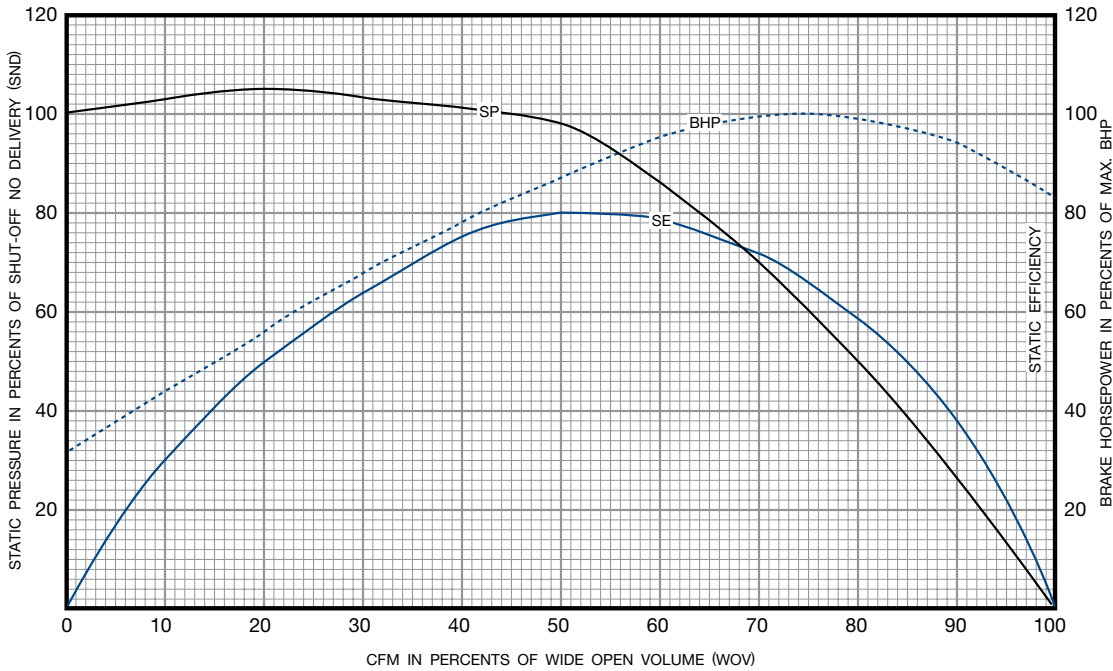

## Submittal Drawing Index

The submittal drawings on pages 36 through 54 represent only a handful of the standard drawings available for layout purposes. For additional drawings refer to the Twin City Fan & Blower Fan Selector Program and Electronic Catalog, or Drawing Supplement 301 which can be found at [www.tcf.com](http://www.tcf.com). For scaled drawings in AutoCad format that can be used for design purposes refer to the FANBLK software. Contact your local Twin City Fan & Blower representative for the Fan Selector and FANBLK software.

### SWSI

ARR.	CLASS	SIZE	ROT.	DWG. NO.	LOCATION
1	I & II	122-270	Yes	9237	Fan Selector
		300-730	No	9238	Page 37
		807-982	No	9259	Page 38
	III	122-330	No	9244	Page 42
		365-890	No	9245	Page 43
		122-330	No	9249	Page 46
		365-890	No	9250	Page 47
3	I & II	122-270	Yes	9240	Fan Selector
			No	9834	Page 39
		330-730	No	9241	Page 40
		807-982	No	9257	Fan Selector
	III	122-330	No	9242	Fan Selector
		365-890	No	9243	Fan Selector
		122-330	No	9247	Fan Selector
IV	365-890	No	9248	Fan Selector	
	I & II	105-200	Yes	16433	Fan Selector
222-365		Yes	16434	Fan Selector	

### SWSI

ARR.	CLASS	SIZE	ROT.	DWG. NO.	LOCATION
9	I & II	122-270	Yes	9239	Page 36
		300-730	No	9238	Fan Selector
	III	122-330	No	9128	Page 44
		365-890	No	9129	Page 45
	IV	122-330	No	9132	Fan Selector
		365-890	No	9133	Fan Selector
9F	I & II	122-270	Yes	14390	Fan Selector
		122-300	No	14391	Fan Selector
		330-730	No	14392	Fan Selector
	III	122-330	No	9130	Fan Selector
		365-890	No	9131	Fan Selector
		122-330	No	9134	Fan Selector
IV	365-890	No	9135	Fan Selector	
	9SB	I, II & III	245-660	No	15401
9ST	I, II & III	245-660	No	15402	Fan Selector
10	I	122-365	Yes	9260	Fan Selector
		402-600	No	9261	Fan Selector
	II	122-365	Yes	14301	Fan Selector
		402-600	No	9261	Fan Selector

### DWDI

ARR.	CLASS	SIZE	ROT.	DWG. NO.	LOCATION
3	I & II	122-270	No	14967	Page 48
		300-730	No	14968	Page 49
		807-982	No	9258	Page 50
3F	I	122-270	No	16026	Page 51
		300-490	No	16027	Page 52
	II	122-270	No	16032	Page 53
		300-490	No	16033	Page 54

# Performance Data

## BC SWSI 122

Outlet Area - 0.86 ft<sup>2</sup>

Wheel Dia. - 12.25 inches

Tip Speed - 3.21 x RPM

Max. BHP = 0.076 (RPM ÷ 1000)<sup>3</sup>

CFM	OV	0.25" SP		0.50" SP		0.75" SP		1" SP		1.5" SP		2" SP		2.5" SP		3" SP		3.5" SP		4" SP		4.5" SP	
		RPM	BHP	RPM	BHP	RPM	BHP	RPM	BHP	RPM	BHP	RPM	BHP	RPM	BHP	RPM	BHP	RPM	BHP	RPM	BHP	RPM	BHP
688	800	869	0.05	1044	0.08	1195	0.12	1335	0.17														
774	900	931	0.06	1096	0.10	1240	0.14	1370	0.18														
860	1000	994	0.07	1152	0.12	1289	0.16	1413	0.21	1642	0.31												
946	1100	1058	0.09	1210	0.13	1342	0.18	1461	0.23	1677	0.34	1879	0.46										
1032	1200	1123	0.11	1271	0.16	1397	0.21	1512	0.26	1720	0.37	1911	0.49	2093	0.63								
1204	1400	1256	0.15	1397	0.21	1514	0.26	1622	0.32	1816	0.45	1992	0.58	2158	0.72	2317	0.87	2471	1.03				
1376	1600	1396	0.20	1525	0.27	1638	0.33	1738	0.40	1922	0.54	2088	0.68	2244	0.83	2390	0.98	2532	1.15	2671	1.33	2805	1.51
1548	1800	1539	0.27	1655	0.34	1765	0.42	1861	0.49	2035	0.64	2193	0.79	2340	0.95	2480	1.12	2612	1.29	2741	1.48	2866	1.67
1720	2000	1685	0.36	1790	0.43	1893	0.51	1988	0.60	2154	0.76	2305	0.93	2445	1.10	2578	1.27	2705	1.46	2827	1.65	2944	1.85
1892	2200	1834	0.46	1929	0.54	2024	0.63	2116	0.72	2277	0.90	2421	1.08	2556	1.26	2683	1.45	2805	1.65	2922	1.84	3035	2.05
2064	2400	1984	0.58	2072	0.66	2159	0.76	2245	0.86	2403	1.06	2542	1.25	2671	1.45	2794	1.65	2911	1.86	3023	2.06	3132	2.28
2236	2600	2135	0.72	2216	0.81	2297	0.91	2377	1.01	2531	1.23	2667	1.44	2791	1.66	2909	1.87	3023	2.09	3131	2.31	3236	2.54
2408	2800	2287	0.88	2363	0.98	2438	1.08	2512	1.19	2659	1.42	2793	1.66	2915	1.89	3028	2.11	3138	2.35	3243	2.58	3344	2.82
2580	3000	2439	1.07	2511	1.17	2581	1.28	2650	1.40	2789	1.64	2921	1.89	3040	2.14	3151	2.38	3256	2.63	3358	2.88	3457	3.13
2752	3200	2593	1.28	2660	1.39	2726	1.51	2791	1.63	2922	1.88	3049	2.15	3167	2.41	3276	2.68	3378	2.94	3477	3.20	3572	3.47
2924	3400	2746	1.52	2810	1.64	2872	1.76	2934	1.89	3057	2.15	3179	2.43	3295	2.72	3402	2.99	3503	3.27	3599	3.55	3691	3.83

CFM	OV	5" SP		5.5" SP		6" SP		7" SP		8" SP		9" SP		10" SP		11" SP		12" SP		13" SP		14" SP	
		RPM	BHP	RPM	BHP	RPM	BHP	RPM	BHP	RPM	BHP	RPM	BHP	RPM	BHP	RPM	BHP	RPM	BHP	RPM	BHP	RPM	BHP
1720	2000	3059	2.05	3172	2.26	3283	2.48	3500	2.94														
1892	2200	3144	2.26	3250	2.48	3355	2.71	3559	3.18	3758	3.67												
2064	2400	3238	2.50	3340	2.73	3440	2.96	3633	3.44	3821	3.95	4006	4.48	4186	5.04								
2236	2600	3337	2.77	3436	3.00	3533	3.25	3719	3.75	3898	4.27	4073	4.81	4245	5.37	4413	5.96	4578	6.56				
2408	2800	3442	3.06	3538	3.31	3631	3.56	3812	4.08	3985	4.61	4152	5.17	4315	5.74	4476	6.34						
2580	3000	3552	3.39	3645	3.64	3735	3.90	3910	4.44	4079	5.00	4240	5.57	4397	6.16	4551	6.77						
2752	3200	3665	3.74	3756	4.01	3843	4.28	4013	4.83	4176	5.40	4335	6.00	4487	6.61								
2924	3400	3781	4.11	3870	4.40	3955	4.69	4120	5.26	4279	5.86	4433	6.47	4582	7.09								
3096	3600	3901	4.52	3986	4.82	4070	5.12	4231	5.73	4386	6.34	4535	6.97										
3268	3800	4023	4.96	4106	5.27	4187	5.59	4345	6.23	4496	6.87												
3440	4000	4147	5.43	4228	5.76	4307	6.09	4461	6.75														
3612	4200	4272	5.93	4352	6.28	4430	6.62	4579	7.31														

MAXIMUM RPM: Class I — 3167 Class II — 4119 Class III — 4600 Selections above 4000 RPM not recommended. Consult factory.

## BC SWSI 135

Outlet Area - 1.05 ft<sup>2</sup>

Wheel Dia. - 13.50 inches

Tip Speed - 3.53 x RPM

Max. BHP = 0.124 (RPM ÷ 1000)<sup>3</sup>

CFM	OV	0.25" SP		0.50" SP		0.75" SP		1" SP		1.5" SP		2" SP		2.5" SP		3" SP		3.5" SP		4" SP		4.5" SP	
		RPM	BHP	RPM	BHP	RPM	BHP	RPM	BHP	RPM	BHP	RPM	BHP	RPM	BHP	RPM	BHP	RPM	BHP	RPM	BHP	RPM	BHP
840	800	791	0.06	949	0.10	1086	0.15	1213	0.20														
945	900	847	0.08	997	0.12	1127	0.17	1245	0.23														
1050	1000	905	0.09	1048	0.14	1172	0.19	1285	0.25	1491	0.38												
1155	1100	963	0.11	1102	0.17	1220	0.22	1328	0.28	1524	0.41	1707	0.56										
1260	1200	1022	0.13	1157	0.19	1271	0.25	1375	0.32	1563	0.45	1736	0.60	1901	0.77								
1470	1400	1144	0.18	1272	0.25	1378	0.32	1475	0.40	1651	0.54	1811	0.70	1960	0.88	2105	1.06	2244	1.26				
1680	1600	1272	0.25	1388	0.33	1491	0.41	1582	0.49	1748	0.65	1899	0.83	2039	1.01	2172	1.20	2300	1.40	2426	1.62	2548	1.85
1890	1800	1403	0.33	1508	0.42	1607	0.51	1695	0.60	1851	0.78	1995	0.97	2128	1.16	2254	1.37	2374	1.58	2490	1.80	2604	2.03
2100	2000	1537	0.44	1631	0.53	1724	0.63	1810	0.73	1960	0.93	2097	1.14	2224	1.34	2344	1.56	2459	1.78	2570	2.02	2676	2.26
2310	2200	1672	0.56	1758	0.66	1844	0.77	1927	0.88	2073	1.10	2203	1.32	2325	1.55	2441	1.78	2550	2.01	2657	2.26	2759	2.51
2520	2400	1809	0.71	1888	0.82	1967	0.93	2045	1.05	2188	1.29	2314	1.53	2431	1.78	2542	2.02	2648	2.27	2750	2.53	2848	2.79
2730	2600	1946	0.88	2020	1.00	2093	1.12	2165	1.24	2304	1.51	2428	1.77	2540	2.03	2647	2.29	2750	2.56	2848	2.83	2943	3.11
2940	2800	2085	1.09	2154	1.21	2221	1.33	2289	1.47	2422	1.75	2543	2.03	2653	2.31	2756	2.59	2855	2.88	2950	3.16	3042	3.45
3150	3000	2224	1.32	2289	1.45	2352	1.58	2415	1.72	2541	2.02	2660	2.32	2768	2.62	2868	2.92	2963	3.22	3056	3.53	3145	3.84
3360	3200	2364	1.58	2425	1.72	2485	1.86	2544	2.00	2662	2.31	2777	2.64	2884	2.96	2982	3.28	3075	3.60	3164	3.92	3251	4.25
3570	3400	2505	1.88	2562	2.02	2618	2.17	2674	2.32	2785	2.64	2895	2.98	3000	3.33	3098	3.68	3189	4.01	3276	4.35	3359	4.69

CFM	OV	5" SP		5.5" SP		6" SP		7" SP		8" SP		9" SP		10" SP		11" SP		12" SP		13" SP		14" SP	
		RPM	BHP	RPM	BHP	RPM	BHP	RPM	BHP	RPM	BHP	RPM	BHP	RPM	BHP	RPM	BHP	RPM	BHP	RPM	BHP	RPM	BHP
2100	2000	2780	2.50	2882	2.76	2982	3.03	3178	3.58														
2310	2200	2858	2.77	2954	3.03	3048	3.30	3233	3.87	3413	4.48												
2520	2400	2944	3.06	3036	3.33	3126	3.62	3301	4.20	3472	4.84	3639	5.47	3801	6.14								
2730	2600	3035	3.39	3124	3.67	3212	3.97	3380	4.57	3542	5.21	3700	5.87	3856	6.56	4008	7.27	4157	8.00				
2940	2800	3131	3.75	3217	4.04	3302	4.35	3466	4.98	3622	5.64	3773	6.31	3921	7.01	4066	7.74	4210	8.49	4350	9.26	4488	10.06
3150	3000	3231	4.14	3315	4.46	3397	4.78	3555	5.42	3708	6.10	3854	6.80	3996	7.52	4135	8.26	4272	9.03	4407	9.82	4540	10.63
3360	3200	3335	4.58	3417	4.91	3496	5.24	3649	5.91	3797	6.61	3941	7.33	4079	8.07	4213	8.83	4344	9.61	4473	10.42		
3570	3400	3441	5.04	3521	5.39	3598	5.74	3748	6.44	3891	7.16	4030	7.90	4166	8.67	4297	9.46	4424	10.26	4548	11.07		
3780	3600	3550	5.54	3627	5.90	3703	6.27	3849	7.01	3989	7.76	4124	8.53	4256	9.31	4384	10.12	4509	10.95				

# BC SWSI 150

Outlet Area - 1.29 ft<sup>2</sup>     Wheel Dia. - 15.00 inches     Tip Speed - 3.93 x RPM     Max. BHP = 0.211 (RPM÷1000)<sup>3</sup>

CFM	OV	0.50" SP		1" SP		1.5" SP		2" SP		3" SP		4" SP		5" SP		6" SP		7" SP		8" SP		9" SP	
		RPM	BHP	RPM	BHP	RPM	BHP	RPM	BHP	RPM	BHP	RPM	BHP	RPM	BHP	RPM	BHP	RPM	BHP	RPM	BHP	RPM	BHP
1032	800	853	0.13	1091	0.25																		
1161	900	896	0.15	1119	0.28																		
1290	1000	941	0.17	1154	0.31	1341	0.47																
1548	1200	1038	0.23	1235	0.39	1405	0.56	1561	0.74														
1806	1400	1141	0.31	1325	0.49	1483	0.67	1627	0.86	1893	1.31												
2064	1600	1245	0.40	1420	0.60	1570	0.80	1706	1.01	1952	1.48												
2322	1800	1352	0.51	1521	0.74	1662	0.96	1791	1.19	2026	1.68	2238	2.21	2441	2.80								
2580	2000	1462	0.65	1624	0.90	1759	1.14	1882	1.39	2106	1.91	2309	2.47	2499	3.08	2682	3.72	2858	4.41				
2838	2200	1576	0.81	1728	1.08	1860	1.35	1978	1.62	2192	2.18	2387	2.77	2568	3.40	2740	4.06	2907	4.76	3070	5.51		
3096	2400	1692	1.00	1834	1.28	1963	1.58	2077	1.88	2283	2.48	2470	3.10	2645	3.76	2809	4.44	2967	5.17	3121	5.93	3272	6.72
3354	2600	1811	1.22	1942	1.52	2067	1.85	2178	2.17	2376	2.81	2557	3.47	2726	4.15	2886	4.87	3037	5.62	3183	6.39	3326	7.21
3612	2800	1930	1.47	2052	1.79	2172	2.14	2282	2.49	2474	3.18	2649	3.88	2812	4.60	2966	5.34	3114	6.12	3255	6.92	3391	7.75
3870	3000	2051	1.76	2165	2.10	2279	2.46	2386	2.84	2574	3.58	2743	4.32	2902	5.08	3051	5.86	3194	6.66	3331	7.49	3463	8.35
4386	3400	2295	2.46	2397	2.83	2497	3.22	2597	3.65	2779	4.49	2940	5.33	3089	6.17	3231	7.03	3366	7.90	3495	8.78	3621	9.70
4902	3800	2543	3.34	2634	3.74	2724	4.17	2814	4.62	2988	5.57	3144	6.51	3286	7.44	3420	8.38	3549	9.34	3673	10.31	3792	11.28
5418	4200	2792	4.41	2875	4.85	2957	5.31	3038	5.79	3200	6.82	3352	7.87	3490	8.91	3618	9.93	3741	10.98	3859	12.03	3974	13.09

CFM	OV	10" SP		11" SP		12" SP		13" SP		14" SP		15" SP		16" SP		17" SP		18" SP		19" SP		20" SP	
		RPM	BHP	RPM	BHP	RPM	BHP	RPM	BHP	RPM	BHP	RPM	BHP	RPM	BHP	RPM	BHP	RPM	BHP	RPM	BHP	RPM	BHP
3096	2400	3419	7.55																				
3354	2600	3467	8.06	3604	8.93	3739	9.84																
3612	2800	3524	8.61	3656	9.51	3785	10.44	3912	11.39	4036	12.37												
3870	3000	3591	9.23	3717	10.15	3840	11.09	3962	12.06	4082	13.06	4200	14.09	4317	15.15								
4128	3200	3665	9.91	3786	10.85	3904	11.81	4021	12.80	4136	13.82	4250	14.86	4362	15.93	4473	17.03	4582	18.15				
4386	3400	3743	10.64	3861	11.61	3975	12.59	4088	13.61	4198	14.64	4307	15.70	4416	16.79	4523	17.91						
4644	3600	3823	11.42	3939	12.42	4051	13.43	4160	14.47	4267	15.52	4373	16.61	4477	17.72	4580	18.85						
4902	3800	3907	12.27	4020	13.29	4130	14.34	4237	15.40	4342	16.49	4444	17.59	4545	18.72								
5160	4000	3994	13.18	4104	14.23	4211	15.29	4316	16.39	4419	17.50	4520	18.65										
5418	4200	4084	14.15	4191	15.23	4296	16.33	4398	17.44	4499	18.59	4598	19.75										
5934	4600	4269	16.26	4373	17.43	4473	18.60	4572	19.79														
6450	5000	4461	18.61	4561	19.87																		

**MAXIMUM RPM:** Class I — 2587    Class II — 3364    Class III — 4253    Class IV — 4580    Selections above 4000 RPM not recommended. Consult factory.

# BC SWSI 165

Outlet Area - 1.57 ft<sup>2</sup>     Wheel Dia. - 16.50 inches     Tip Speed - 4.32 x RPM     Max. BHP = 0.339 (RPM÷1000)<sup>3</sup>

CFM	OV	0.50" SP		1" SP		1.5" SP		2" SP		3" SP		4" SP		5" SP		6" SP		7" SP		8" SP		9" SP	
		RPM	BHP	RPM	BHP	RPM	BHP	RPM	BHP	RPM	BHP	RPM	BHP	RPM	BHP	RPM	BHP	RPM	BHP	RPM	BHP	RPM	BHP
1256	800	777	0.15	992	0.30																		
1413	900	816	0.18	1019	0.34																		
1570	1000	858	0.21	1051	0.38	1220	0.57																
1884	1200	947	0.29	1125	0.47	1279	0.68	1421	0.90														
2198	1400	1041	0.38	1208	0.59	1351	0.81	1482	1.05	1722	1.59												
2512	1600	1137	0.49	1295	0.73	1431	0.98	1554	1.24	1778	1.80	1985	2.42										
2826	1800	1234	0.63	1387	0.90	1516	1.17	1633	1.45	1845	2.05	2038	2.70	2222	3.40								
3140	2000	1335	0.79	1482	1.10	1604	1.39	1716	1.70	1919	2.33	2103	3.01	2275	3.74	2441	4.53	2601	5.36				
3454	2200	1440	0.99	1577	1.32	1697	1.65	1803	1.98	1998	2.66	2174	3.37	2339	4.14	2495	4.94	2646	5.80	2793	6.69		
3768	2400	1546	1.22	1674	1.57	1791	1.94	1894	2.29	2081	3.03	2250	3.78	2409	4.57	2559	5.41	2702	6.29	2841	7.21	2977	8.17
4082	2600	1654	1.49	1773	1.86	1887	2.26	1987	2.65	2167	3.43	2331	4.23	2484	5.06	2629	5.93	2766	6.84	2899	7.79	3028	8.77
4396	2800	1764	1.81	1874	2.19	1983	2.62	2082	3.04	2256	3.88	2415	4.73	2563	5.61	2702	6.50	2836	7.45	2964	8.42	3088	9.44
4710	3000	1874	2.16	1977	2.57	2080	3.01	2177	3.47	2348	4.37	2501	5.28	2645	6.20	2780	7.14	2910	8.12	3035	9.13	3154	10.16
5338	3400	2098	3.03	2190	3.48	2280	3.95	2370	4.46	2536	5.50	2682	6.52	2817	7.54	2945	8.58	3068	9.64	3185	10.71	3299	11.82
5966	3800	2324	4.11	2407	4.60	2488	5.11	2569	5.66	2727	6.82	2869	7.97	2997	9.09	3119	10.24	3236	11.41	3348	12.58	3456	13.76
6594	4200	2552	5.43	2627	5.96	2701	6.52	2774	7.10	2921	8.35	3059	9.64	3184	10.89	3301	12.15	3412	13.41	3519	14.69	3623	15.98

CFM	OV	10" SP		11" SP		12" SP		13" SP		14" SP		15" SP		16" SP		17" SP		18" SP		19" SP		20" SP	
		RPM	BHP	RPM	BHP	RPM	BHP	RPM	BHP	RPM	BHP	RPM	BHP	RPM	BHP	RPM	BHP	RPM	BHP	RPM	BHP	RPM	BHP
3768	2400	3111	9.18																				
4082	2600	3155	9.80	3280	10.86	3402	11.96																
4396	2800	3209	10.49	3328	11.57	3445	12.70	3560	13.85	3673	15.04												
4710	3000	3271	11.25	3384	12.35	3496	13.50	3606	14.67	3715	15.89	3822	17.13	3928	18.41								
5024	3200	3338	12.07	3448	13.21	3555	14.37	3661	15.58	3765	16.81	3868	18.07	3970	19.37	4070	20.70	4169	22.05	4307	24.56	4400	25.99
5338	3400	3410	12.97	3516	14.13	3621	15.34	3722	16.55	3823	17.82	3921	19.10	4019	20.42	4116	21.77	4212	23.15	4353	25.76	4444	27.22
5652	3600	3483	13.92	3588	15.13	3690	16.36	3789	17.62	3886	18.90	3982	20.22	4076	21.56	4169	22.93	4262	24.34	4353	25.76	4444	27.22
5966	3800	3560	14.96	3662	16.19	3762	17.46	3860	18.77	3955	20.09	4047	21.41	4139	22.79	4229	24.19	4318	25.61	4406	27.06	4493	28.52
6280	4000	3640	16.08	3740	17.35	3837	18.65	3933	19.98	4026	21.33	4117	22.71	4206	24.11	4294	25.54	4380	26.98	4465	28.44	4550	29.95
6594	4200	3723	17.28	3820	18.59	3915	19.92	4008	21.27	4099	22.65	4189	24.07	4276	25.50	4362	26.96	4446	28.43	4529	29.93		
7222	4600	3893	19.87	3987	21.29	4078	22.71	4167	24.14	4254	25.59	4339	27.05	4424	28.57	4507	30.09	4588	31.63				
7850	5000	4069	22.75	4159	24.26	4247	25.79	4334	27.34	4418	28.89	4500	30.44	4581	32.01								

# BC SWSI 182

Outlet Area - 1.92 ft<sup>2</sup>      Wheel Dia. - 18.25 inches      Tip Speed - 4.78 x RPM      Max. BHP = 0.552 (RPM÷1000)<sup>3</sup>

CFM	OV	0.50" SP		1" SP		1.5" SP		2" SP		3" SP		4" SP		5" SP		6" SP		7" SP		8" SP		9" SP	
		RPM	BHP	RPM	BHP	RPM	BHP	RPM	BHP	RPM	BHP	RPM	BHP	RPM	BHP	RPM	BHP	RPM	BHP	RPM	BHP	RPM	BHP
1536	800	695	0.17																				
1728	900	724	0.20	932	0.38																		
1920	1000	757	0.24	951	0.42	1126	0.64																
2304	1200	831	0.32	1002	0.53	1160	0.76	1306	1.02														
2688	1400	914	0.42	1066	0.66	1208	0.91	1342	1.19														
3072	1600	1003	0.55	1138	0.81	1267	1.09	1391	1.39	1621	2.03												
3456	1800	1096	0.71	1217	1.00	1335	1.30	1449	1.62	1663	2.30	1864	3.06										
3840	2000	1191	0.91	1302	1.22	1409	1.55	1514	1.88	1714	2.61	1903	3.40	2081	4.24	2252	5.15						
4224	2200	1288	1.13	1391	1.48	1489	1.83	1586	2.20	1773	2.96	1950	3.78	2120	4.67	2282	5.60	2437	6.58				
4608	2400	1387	1.40	1482	1.78	1573	2.16	1663	2.55	1838	3.36	2005	4.22	2165	5.13	2320	6.11	2469	7.13	2612	8.18		
4992	2600	1487	1.71	1576	2.12	1661	2.53	1744	2.94	1908	3.81	2066	4.71	2218	5.66	2365	6.67	2507	7.72	2645	8.81	2779	9.95
5376	2800	1588	2.07	1671	2.50	1751	2.94	1829	3.39	1982	4.30	2132	5.25	2276	6.25	2416	7.28	2553	8.38	2685	9.51	2814	10.68
5760	3000	1689	2.47	1768	2.94	1843	3.41	1917	3.88	2061	4.86	2202	5.85	2340	6.89	2473	7.97	2604	9.09	2730	10.25	2854	11.46
6528	3400	1895	3.46	1964	3.98	2032	4.50	2099	5.04	2227	6.12	2354	7.23	2479	8.36	2601	9.53	2720	10.73	2837	11.97	2952	13.25
7296	3800	2102	4.68	2165	5.26	2226	5.85	2287	6.45	2404	7.64	2518	8.85	2631	10.09	2743	11.35	2853	12.64	2961	13.97	3067	15.33
8064	4200	2310	6.17	2368	6.82	2424	7.47	2479	8.12	2587	9.43	2692	10.76	2795	12.11	2897	13.48	2999	14.87	3099	16.28	3197	17.71

CFM	OV	10" SP		11" SP		12" SP		13" SP		14" SP		15" SP		16" SP		17" SP		18" SP		19" SP		20" SP	
		RPM	BHP	RPM	BHP	RPM	BHP	RPM	BHP	RPM	BHP	RPM	BHP	RPM	BHP	RPM	BHP	RPM	BHP	RPM	BHP	RPM	BHP
4608	2400																						
4992	2600	2909	11.13																				
5376	2800	2939	11.89	3061	13.14																		
5760	3000	2975	12.71	3093	13.99	3208	15.31	3321	16.66														
6144	3200	3017	13.60	3131	14.92	3243	16.28	3352	17.66	3459	19.08	3565	20.54										
6528	3400	3064	14.56	3174	15.91	3282	17.30	3388	18.72	3492	20.17	3594	21.66	3695	23.19	3794	24.74						
6912	3600	3116	15.60	3222	16.99	3326	18.40	3429	19.87	3530	21.35	3630	22.89	3727	24.42	3823	26.00	3918	27.62	4012	29.27		
7296	3800	3172	16.72	3274	18.13	3375	19.59	3475	21.10	3573	22.62	3669	24.17	3764	25.75	3858	27.38	3950	29.01	4041	30.69	4131	32.40
7680	4000	3231	17.91	3331	19.39	3428	20.86	3525	22.40	3620	23.97	3713	25.55	3806	27.18	3897	28.83	3987	30.51	4075	32.20	4163	33.94
8064	4200	3295	19.21	3391	20.71	3485	22.23	3579	23.81	3671	25.40	3761	27.01	3851	28.67	3940	30.37	4027	32.07	4114	33.82	4199	35.58
8832	4600	3431	22.03	3520	23.61	3609	25.24	3696	26.87	3783	28.55	3869	30.25	3954	31.98	4037	33.71	4120	35.50	4202	37.32	4283	39.15
9600	5000	3577	25.23	3661	26.90	3744	28.59	3827	30.34	3908	32.19	3989	33.87	4069	35.67	4148	37.49	4227	39.36	4305	41.24	4382	43.14

MAXIMUM RPM:    Class I — 2118    Class II — 2729    Class III — 3473    Class IV — 3766

# BC SWSI 200

Outlet Area - 2.30 ft<sup>2</sup>      Wheel Dia. - 20.00 inches      Tip Speed - 5.24 x RPM      Max. BHP = 0.872 (RPM÷1000)<sup>3</sup>

CFM	OV	0.50" SP		1" SP		1.5" SP		2" SP		3" SP		4" SP		5" SP		6" SP		7" SP		8" SP		9" SP	
		RPM	BHP	RPM	BHP	RPM	BHP	RPM	BHP	RPM	BHP	RPM	BHP	RPM	BHP	RPM	BHP	RPM	BHP	RPM	BHP	RPM	BHP
1840	800	634	0.21																				
2070	900	660	0.24	850	0.46																		
2300	1000	690	0.28	868	0.51	1027	0.77																
2760	1200	758	0.38	914	0.63	1058	0.91	1191	1.22														
3220	1400	833	0.51	971	0.78	1102	1.09	1224	1.42														
3680	1600	914	0.66	1037	0.97	1155	1.30	1268	1.66	1479	2.44												
4140	1800	998	0.85	1109	1.20	1217	1.56	1321	1.94	1517	2.76	1700	3.66										
4600	2000	1085	1.08	1186	1.46	1284	1.85	1380	2.25	1563	3.12	1735	4.07	1899	5.09	2054	6.17						
5060	2200	1173	1.35	1267	1.77	1357	2.19	1445	2.62	1616	3.54	1778	4.53	1933	5.59	2081	6.71	2223	7.89				
5520	2400	1263	1.67	1350	2.12	1433	2.58	1515	3.05	1675	4.02	1828	5.05	1975	6.15	2116	7.32	2252	8.54	2383	9.81		
5980	2600	1354	2.04	1435	2.53	1513	3.02	1589	3.52	1739	4.55	1883	5.64	2022	6.78	2157	7.99	2287	9.25	2413	10.56	2535	11.93
6440	2800	1446	2.47	1522	2.99	1595	3.52	1666	4.05	1806	5.14	1943	6.28	2075	7.48	2203	8.72	2328	10.03	2449	11.39	2566	12.79
6900	3000	1538	2.95	1610	3.51	1679	4.07	1746	4.64	1878	5.81	2007	7.00	2133	8.25	2255	9.54	2374	10.88	2490	12.28	2603	13.73
7820	3400	1725	4.12	1789	4.75	1851	5.38	1911	6.02	2029	7.31	2145	8.65	2259	10.00	2371	11.40	2480	12.84	2587	14.33	2691	15.85
8740	3800	1913	5.58	1971	6.28	2027	6.98	2082	7.69	2189	9.12	2294	10.58	2398	12.08	2500	13.58	2600	15.12	2699	16.72	2796	18.34
9660	4200	2103	7.36	2155	8.13	2207	8.91	2257	9.68	2356	11.26	2452	12.86	2546	14.47	2640	16.12	2733	17.79	2824	19.47	2914	21.19

CFM	OV	10" SP		11" SP		12" SP		13" SP		14" SP		15" SP		16" SP		17" SP		18" SP		19" SP		20" SP	
		RPM	BHP	RPM	BHP	RPM	BHP	RPM	BHP	RPM	BHP	RPM	BHP	RPM	BHP	RPM	BHP	RPM	BHP	RPM	BHP	RPM	BHP
5520	2400																						
5980	2600	2654	13.35																				
6440	2800	2681	14.25	2792	15.74																		
6900	3000	2713	15.22	2821	16.76	2926	18.34	3030	19.98														
7360	3200	2751	16.28	2856	17.88	2958	19.50	3057	21.15	3155	22.85	3252	24.61										
7820	3400	2794	17.44	2894	19.05	2993	20.72	3090	22.43	3185	24.17	3279	25.97	3370	27.77	3461	29.64						
8280	3600	2841	18.68	2938	20.34	3033	22.04	3127	23.79	3220	25.59	3310	27.40	3400	29.28	3487	31.15	3574	33.10	3660	35.08		
8740	3800	2892	20.02	2985	21.71	3078	23.47	3169	25.27	3258	27.08	3346	28.94	3433	30.85	3519	32.80	3603	34.76	3686	36.77	3768	38.81
9200	4000	2946	21.45	3036	23.18	3126	24.99	3214	26.82	3301	28.70	3386	30.59	3471	32.56	3554	34.53	3636	36.54	3717	38.58	3797	40.66
9660	4200	3003	22.97	3091	24.78	3177	26.61	3263	28.50	3347	30.40	3430	32.35	3512	34.34	3593	36.37	3673	38.42	3752	40.51	3830	42.63
10580	4600	3127	26.35	3209	28.26	3290	30.21	3370	32.17	3449	34.17	3527	36.19	3605	38.28	3681	40.36	3757	42.51	3832	44.69	3906	46.89
11500	5000	3259	30.15	3336	32.16	3412	34.19	3488	36.29	3562	38.38	3636	40.52	3710	42.71	3782	44.89	3854	47.11	3925	49.36	3	

# BC SWSI 222

Outlet Area - 2.85 ft<sup>2</sup>    Wheel Dia. - 22.25 inches    Tip Speed - 5.83 x RPM    Max. BHP = 1.49 (RPM÷1000)<sup>3</sup>

CFM	OV	0.50" SP		1" SP		1.5" SP		2" SP		3" SP		4" SP		5" SP		6" SP		7" SP		8" SP		9" SP	
		RPM	BHP	RPM	BHP	RPM	BHP	RPM	BHP	RPM	BHP	RPM	BHP	RPM	BHP	RPM	BHP	RPM	BHP	RPM	BHP	RPM	BHP
2280	800	570	0.26																				
2565	900	594	0.30	764	0.57																		
2850	1000	621	0.35	780	0.63	923	0.95																
3420	1200	681	0.47	822	0.78	951	1.13	1071	1.52														
3990	1400	749	0.63	874	0.97	991	1.35	1101	1.76														
4560	1600	822	0.82	933	1.21	1039	1.62	1140	2.05	1330	3.02												
5130	1800	898	1.06	998	1.49	1094	1.93	1188	2.40	1364	3.42	1528	4.53										
5700	2000	976	1.34	1067	1.81	1155	2.29	1241	2.79	1405	3.87	1560	5.04	1707	6.30	1847	7.64						
6270	2200	1055	1.68	1139	2.19	1220	2.71	1300	3.26	1453	4.39	1599	5.61	1738	6.92	1871	8.31	1999	9.78				
6840	2400	1136	2.07	1214	2.63	1289	3.20	1363	3.78	1506	4.98	1644	6.27	1775	7.62	1902	9.06	2024	10.57	2142	12.15		
7410	2600	1218	2.53	1291	3.13	1361	3.74	1429	4.36	1564	5.64	1693	6.98	1818	8.40	1939	9.89	2056	11.46	2169	13.08	2279	14.78
7980	2800	1301	3.06	1369	3.71	1435	4.36	1499	5.02	1625	6.38	1747	7.78	1866	9.27	1981	10.81	2093	12.43	2202	14.12	2307	15.84
8550	3000	1384	3.67	1448	4.35	1510	5.05	1571	5.76	1689	7.20	1805	8.68	1918	10.22	2028	11.83	2135	13.50	2239	15.23	2340	17.01
9690	3400	1552	5.11	1609	5.89	1665	6.68	1720	7.47	1825	9.07	1929	10.72	2032	12.40	2132	14.13	2230	15.92	2326	17.76	2420	19.65
10830	3800	1722	6.93	1773	7.79	1824	8.67	1874	9.55	1970	11.33	2064	13.14	2157	14.98	2248	16.83	2339	18.76	2427	20.72	2514	22.73
11970	4200	1893	9.15	1940	10.10	1986	11.06	2031	12.02	2120	13.98	2206	15.96	2290	17.95	2375	20.01	2458	22.06	2540	24.14	2621	26.29

CFM	OV	10" SP		11" SP		12" SP		13" SP		14" SP		15" SP		16" SP		17" SP		18" SP		19" SP		20" SP	
		RPM	BHP	RPM	BHP	RPM	BHP	RPM	BHP	RPM	BHP	RPM	BHP	RPM	BHP	RPM	BHP	RPM	BHP	RPM	BHP	RPM	BHP
6840	2400																						
7410	2600	<b>2386</b>	<b>16.54</b>																				
7980	2800	<b>2410</b>	<b>17.65</b>	2510	19.50																		
8550	3000	<b>2440</b>	<b>18.87</b>	2536	20.76	2631	22.73	2724	24.75														
9120	3200	2474	20.19	2567	22.13	2659	24.15	2749	26.22	2837	28.33	2923	30.48										
9690	3400	2512	21.60	2603	23.63	2691	25.67	2778	27.78	2864	29.96	2948	32.18	3030	34.42	3112	36.74						
10260	3600	2554	23.13	2642	25.21	2727	27.31	2812	29.50	2895	31.71	2976	33.95	3057	36.28	3135	38.60	3213	41.00	3290	43.45		
10830	3800	2600	24.80	2685	26.93	2767	29.07	2849	31.30	2929	33.55	3009	35.89	3087	38.24	3164	40.65	3239	43.06	3314	45.56	3388	48.11
11400	4000	2649	26.58	2731	28.77	2811	30.97	2890	33.24	2968	35.56	3045	37.93	3120	40.31	3195	42.77	3269	45.27	3342	47.81	3414	50.40
11970	4200	2701	28.49	2780	30.73	2857	32.98	2934	35.31	3009	37.66	3084	40.09	3158	42.57	3230	45.04	3302	47.60	3373	50.18	3443	52.80
13110	4600	2812	32.66	2886	35.04	2958	37.42	3030	39.86	3102	42.38	3172	44.88	3241	47.42	3310	50.03	3378	52.68	3445	55.36	3512	58.11
14250	5000	2932	37.42	3001	39.90	3069	42.41	3137	45.00	3204	47.61	3270	50.24	3336	52.94	3401	55.64	3466	58.42	3529	61.16	3593	64.03

MAXIMUM RPM:    Class I — 1737    Class II — 2238    Class III — 2848    Class IV — 3088

# BC SWSI 245

Outlet Area - 3.45 ft<sup>2</sup>    Wheel Dia. - 24.50 inches    Tip Speed - 6.41 x RPM    Max. BHP = 2.40 (RPM÷1000)<sup>3</sup>

CFM	OV	0.50" SP		1" SP		1.5" SP		2" SP		3" SP		4" SP		5" SP		6" SP		7" SP		8" SP		9" SP	
		RPM	BHP	RPM	BHP	RPM	BHP	RPM	BHP	RPM	BHP	RPM	BHP	RPM	BHP	RPM	BHP	RPM	BHP	RPM	BHP	RPM	BHP
2760	800	517	0.31																				
3105	900	539	0.36	694	0.69																		
3450	1000	563	0.42	708	0.76	838	1.15																
4140	1200	618	0.57	746	0.95	863	1.37	972	1.84														
4830	1400	680	0.76	793	1.18	899	1.63	999	2.13														
5520	1600	746	0.99	846	1.46	943	1.96	1035	2.49	1207	3.65												
6210	1800	815	1.28	905	1.79	993	2.33	1078	2.90	1238	4.13	1388	5.49										
6900	2000	885	1.62	968	2.19	1048	2.77	1126	3.38	1276	4.69	1416	6.10	1550	7.63	1677	9.25						
7590	2200	957	2.03	1034	2.65	1107	3.28	1180	3.94	1319	5.32	1452	6.80	1578	8.38	1699	10.07	1815	11.84				
8280	2400	1031	2.51	1101	3.17	1170	3.87	1237	4.57	1367	6.02	1492	7.58	1612	9.23	1727	10.97	1838	12.80	1945	14.71		
8970	2600	1105	3.06	1171	3.79	1235	4.53	1297	5.28	1419	6.82	1537	8.46	1651	10.18	1760	11.97	1867	13.88	1969	15.83	2069	17.89
9660	2800	1180	3.70	1242	4.48	1301	5.26	1360	6.07	1474	7.71	1586	9.43	1694	11.22	1798	13.07	1900	15.04	1999	17.08	2095	19.19
10350	3000	1255	4.42	1313	5.25	1370	6.10	1425	6.96	1532	8.70	1638	10.49	1741	12.37	1840	14.30	1938	16.33	2032	18.41	2125	20.60
11730	3400	1408	6.18	1460	7.12	1510	8.06	1560	9.03	1656	10.97	1751	12.97	1844	15.00	1935	17.09	2024	19.26	2111	21.48	2197	23.79
13110	3800	1561	8.36	1608	9.41	1654	10.46	1699	11.53	1787	13.69	1872	15.87	1957	18.11	2040	20.36	2122	22.67	2203	25.07	2282	27.51
14490	4200	1716	11.03	1759	12.19	1801	13.36	1842	14.52	1923	16.90	2001	19.28	2078	21.71	2155	24.19	2230	26.66	2305	29.20	2379	31.81

CFM	OV	10" SP		11" SP		12" SP		13" SP		14" SP		15" SP		16" SP		17" SP		18" SP		19" SP		20" SP	
		RPM	BHP	RPM	BHP	RPM	BHP	RPM	BHP	RPM	BHP	RPM	BHP	RPM	BHP	RPM	BHP	RPM	BHP	RPM	BHP	RPM	BHP
8280	2400																						
8970	2600	<b>2166</b>	<b>20.01</b>																				
9660	2800	<b>2188</b>	<b>21.36</b>	2279	23.61																		
10350	3000	<b>2215</b>	<b>22.84</b>	2303	25.15	2389	27.53	2473	29.96														
11040	3200	2246	24.44	2331	26.81	2414	29.23	2496	31.75	2576	34.31	2654	36.90										
11730	3400	2280	26.13	2363	28.60	2443	31.08	2522	33.63	2600	36.26	2676	38.93	2751	41.67	2825	44.46						
12420	3600	2319	28.01	2398	30.50	2476	33.07	2553	35.71	2628	38.37	2702	41.10	2775	43.90	2847	46.76	2917	49.63	2987	52.60		
13110	3800	2360	30.01	2437	32.58	2512	35.19	2586	37.87	2659	40.61	2731	43.41	2802	46.27	2872	49.18	2941	52.15	3009	55.17	3076	58.24
13800	4000	2404	32.15	2478	34.77	2551	37.46	2623	40.21	2694	43.03	2764	45.90	2833	48.82	2901	51.79	2968	54.81	3034	57.87	3099	60.97
14490	4200	2451	34.45	2523	37.17	2593	39.90	2663	42.72	2732	45.60	2800	48.54	2866	51.48	2933	54.56	2998	57.63	3062	60.73	3126	63.93
15870	4600	2552	39.51	2619	42.37	2685	45.29	2750	48.22	2815	51.24	2879	54.29	2942	57.38	3005	60.57	3067	63.79	3128	67.05	3188	70.32
17250	5000	2660	45.23	2723	48.24	2785	51.29	2847	54.43	2908	57.61	2968	60.79	3028	64.05	3087	67.33	3146	70.68	3204	74.06	3261	77.46

MAXIMUM RPM:    Class I — 1577    Class II — 2033    Class III — 2587    Class IV — 2808

Performance certified is for installation Type B & D: Free or ducted inlet, ducted outlet.  
Power rating (BHP) does not include transmission losses.  
Performance ratings do not include the effects of appurtenances (accessories).

## Legend:

Class I = Regular face to left of



# BC SWSI 330

Outlet Area - 6.26 ft<sup>2</sup>

Wheel Dia. - 33.00 inches

Tip Speed - 8.64 x RPM

Max. BHP = 11.05 (RPM÷1000)<sup>3</sup>

CFM	OV	0.50" SP		1" SP		1.5" SP		2" SP		3" SP		4" SP		5" SP		6" SP		7" SP		8" SP		9" SP	
		RPM	BHP	RPM	BHP	RPM	BHP	RPM	BHP	RPM	BHP	RPM	BHP	RPM	BHP	RPM	BHP	RPM	BHP	RPM	BHP	RPM	BHP
5008	800	374	0.54	484	1.07																		
5634	900	392	0.64	493	1.18	593	1.90																
6260	1000	412	0.75	508	1.33	594	1.99																
7512	1200	455	1.02	541	1.67	<b>618</b>	2.37	<b>690</b>	3.17														
8764	1400	502	1.36	580	2.09	650	2.86	716	3.70	839	5.60												
10016	1600	551	1.78	622	2.60	688	3.47	748	4.35	<b>860</b>	6.30												
11268	1800	602	2.30	668	3.22	728	4.16	785	5.14	890	7.19	<b>987</b>	9.45	1083	12.02	<b>1186</b>	15.19						
12520	2000	655	2.93	715	3.93	771	4.96	824	6.01	923	8.21	1015	10.57	1102	13.13	<b>1188</b>	15.95	<b>1280</b>	19.34				
13772	2200	708	3.66	764	4.77	817	5.89	867	7.04	960	9.39	1047	11.86	1130	14.53	1208	17.31	<b>1286</b>	20.37	<b>1368</b>	23.89		
15024	2400	762	4.52	814	5.72	864	6.95	911	8.18	1000	10.72	1082	13.32	<b>1161</b>	16.09	<b>1236</b>	18.99	<b>1308</b>	22.04	<b>1379</b>	25.29	1453	28.95
16276	2600	817	5.53	866	6.84	912	8.13	957	9.47	1041	12.17	1120	14.96	1195	17.84	1267	20.85	<b>1336</b>	24.00	<b>1403</b>	27.31	<b>1468</b>	30.73
17528	2800	873	6.70	918	8.08	962	9.49	1004	10.89	1084	13.77	1160	16.75	1232	19.81	1301	22.95	<b>1367</b>	26.17	<b>1432</b>	29.61	<b>1494</b>	33.11
18780	3000	929	8.02	972	9.52	1013	11.01	1053	12.51	1129	15.56	1202	18.73	1271	21.95	1337	25.23	1401	28.61	<b>1463</b>	32.10	<b>1523</b>	35.72
21284	3400	1041	11.17	1080	12.88	1117	14.57	1153	16.26	1223	19.70	1290	23.22	1353	26.73	1415	30.38	1474	34.05	<b>1532</b>	37.83	<b>1588</b>	41.65
23788	3800	1155	15.14	1190	17.04	1224	18.94	1257	20.84	1321	24.65	1382	28.47	1441	32.37	1499	36.38	<b>1554</b>	40.36	<b>1608</b>	44.45	<b>1661</b>	48.62
26292	4200	1270	20.01	1301	22.05	1332	24.14	1363	26.28	1422	30.48	1479	34.70	1534	38.95	1587	43.24	<b>1640</b>	47.68	<b>1690</b>	52.02	<b>1740</b>	56.54

CFM	OV	10" SP		11" SP		12" SP		13" SP		14" SP		15" SP		16" SP		17" SP		18" SP		19" SP		20" SP	
		RPM	BHP	RPM	BHP	RPM	BHP	RPM	BHP	RPM	BHP	RPM	BHP	RPM	BHP	RPM	BHP	RPM	BHP	RPM	BHP	RPM	BHP
15024	2400	<b>1529</b>	<b>33.02</b>																				
16276	2600	<b>1535</b>	<b>34.49</b>	<b>1605</b>	<b>38.71</b>	<b>1676</b>	<b>43.27</b>																
17528	2800	<b>1555</b>	<b>36.77</b>	<b>1616</b>	<b>40.63</b>	<b>1679</b>	<b>44.85</b>	<b>1744</b>	<b>49.47</b>	<b>1810</b>	<b>54.43</b>												
18780	3000	<b>1581</b>	<b>39.42</b>	<b>1638</b>	<b>43.25</b>	<b>1695</b>	<b>47.29</b>	<b>1753</b>	<b>51.60</b>	<b>1812</b>	<b>56.20</b>	<b>1873</b>	<b>61.22</b>	<b>1935</b>	<b>66.58</b>								
20032	3200	<b>1611</b>	<b>42.39</b>	<b>1666</b>	<b>46.33</b>	<b>1720</b>	<b>50.39</b>	<b>1773</b>	<b>54.54</b>	<b>1827</b>	<b>58.98</b>	<b>1881</b>	<b>63.59</b>	<b>1937</b>	<b>68.59</b>	<b>1994</b>	<b>73.93</b>	<b>2052</b>	<b>79.59</b>	<b>2108</b>	<b>87.52</b>	<b>2163</b>	<b>93.54</b>
21284	3400	<b>1643</b>	<b>45.61</b>	<b>1697</b>	<b>49.71</b>	<b>1749</b>	<b>53.84</b>	<b>1800</b>	<b>58.08</b>	<b>1850</b>	<b>62.40</b>	<b>1900</b>	<b>66.90</b>	<b>1951</b>	<b>71.67</b>	<b>2002</b>	<b>76.61</b>	<b>2055</b>	<b>81.96</b>	<b>2117</b>	<b>90.64</b>	<b>2167</b>	<b>96.28</b>
22536	3600	<b>1677</b>	<b>49.10</b>	<b>1729</b>	<b>53.27</b>	<b>1780</b>	<b>57.55</b>	<b>1830</b>	<b>61.94</b>	<b>1878</b>	<b>66.31</b>	<b>1926</b>	<b>70.87</b>	<b>1974</b>	<b>75.59</b>	<b>2021</b>	<b>80.37</b>	<b>2069</b>	<b>85.42</b>	<b>2129</b>	<b>94.84</b>	<b>2181</b>	<b>100.11</b>
23788	3800	<b>1712</b>	<b>52.79</b>	<b>1763</b>	<b>57.12</b>	<b>1812</b>	<b>61.45</b>	<b>1861</b>	<b>65.98</b>	<b>1909</b>	<b>70.60</b>	<b>1955</b>	<b>75.19</b>	<b>2001</b>	<b>79.95</b>	<b>2046</b>	<b>84.75</b>	<b>2091</b>	<b>89.72</b>	<b>2136</b>	<b>94.84</b>	<b>2181</b>	<b>100.11</b>
25040	4000	<b>1750</b>	<b>56.85</b>	<b>1799</b>	<b>61.29</b>	<b>1847</b>	<b>65.79</b>	<b>1894</b>	<b>70.35</b>	<b>1940</b>	<b>74.99</b>	<b>1986</b>	<b>79.81</b>	<b>2031</b>	<b>84.70</b>	<b>2075</b>	<b>89.64</b>	<b>2118</b>	<b>94.61</b>	<b>2161</b>	<b>99.74</b>	<b>2203</b>	<b>104.88</b>
26292	4200	<b>1789</b>	<b>61.13</b>	<b>1836</b>	<b>65.67</b>	<b>1883</b>	<b>70.35</b>	<b>1929</b>	<b>75.07</b>	<b>1974</b>	<b>79.85</b>	<b>2018</b>	<b>84.67</b>	<b>2062</b>	<b>89.67</b>	<b>2105</b>	<b>94.72</b>	<b>2148</b>	<b>99.95</b>	<b>2189</b>	<b>105.05</b>	<b>2230</b>	<b>110.31</b>
28796	4600	<b>1870</b>	<b>70.39</b>	<b>1915</b>	<b>75.31</b>	<b>1959</b>	<b>80.27</b>	<b>2003</b>	<b>85.36</b>	<b>2045</b>	<b>90.32</b>	<b>2087</b>	<b>95.42</b>	<b>2129</b>	<b>100.67</b>	<b>2170</b>	<b>105.93</b>	<b>2211</b>	<b>111.36</b>	<b>2251</b>	<b>116.79</b>	<b>2290</b>	<b>122.24</b>
31300	5000	<b>1955</b>	<b>80.75</b>	<b>1998</b>	<b>86.04</b>	<b>2040</b>	<b>91.33</b>	<b>2082</b>	<b>96.78</b>	<b>2122</b>	<b>102.09</b>	<b>2163</b>	<b>107.67</b>	<b>2202</b>	<b>113.06</b>	<b>2241</b>	<b>118.59</b>	<b>2280</b>	<b>124.24</b>	<b>2318</b>	<b>129.87</b>	<b>2355</b>	<b>135.47</b>

MAXIMUM RPM: Class I — 1143 Class II — 1475 Class III — 1871 Class IV — 2081

# BC SWSI 365

Outlet Area - 7.66 ft<sup>2</sup>

Wheel Dia. - 36.50 inches

Tip Speed - 9.56 x RPM

Max. BHP = 19.42 (RPM÷1000)<sup>3</sup>

CFM	OV	0.50" SP		1" SP		1.5" SP		2" SP		3" SP		4" SP		5" SP		6" SP		7" SP		8" SP		9" SP	
		RPM	BHP	RPM	BHP	RPM	BHP	RPM	BHP	RPM	BHP	RPM	BHP	RPM	BHP	RPM	BHP	RPM	BHP	RPM	BHP	RPM	BHP
6128	800	326	0.65	430	1.27																		
6894	900	342	0.76	435	1.41																		
7660	1000	359	0.89	445	1.58	527	2.37																
9192	1200	397	1.20	472	1.99	543	2.86	610	3.77														
10724	1400	439	1.60	505	2.48	567	3.41	628	4.44	744	6.63												
12256	1600	483	2.09	542	3.07	598	4.09	653	5.20	<b>758</b>	<b>7.57</b>	859	10.14										
13788	1800	529	2.70	582	3.77	633	4.89	683	6.08	779	8.62	871	11.33	961	14.26								
15320	2000	577	3.46	625	4.61	671	5.82	717	7.09	805	9.79	890	12.68	972	15.70	<b>1053</b>	<b>18.93</b>						
16852	2200	625	4.34	669	5.58	712	6.90	754	8.26	836	11.14	915	14.20	992	17.44	<b>1066</b>	<b>20.75</b>	<b>1139</b>	<b>24.23</b>	<b>1215</b>	<b>28.13</b>		
18384	2400	674	5.38	715	6.73	754	8.11	793	9.58	869	12.62	943	15.85	1015	19.26	1085	22.79	<b>1153</b>	<b>26.39</b>	<b>1221</b>	<b>30.22</b>	1289	34.27
19916	2600	724	6.62	761	8.02	798	9.52	835	11.10	906	14.34	975	17.72	1042	21.26	1108	24.97	1173	28.83	<b>1236</b>	<b>32.73</b>	<b>1298</b>	<b>36.75</b>
21448	2800	774	8.03	809	9.54	843	11.10	877	12.75	944	16.20	1009	19.76	1073	23.51	1135	27.37	1196	31.37	1256	35.49	<b>1315</b>	<b>39.71</b>
22980	3000	824	9.62	857	11.24	889	12.89	921	14.63	984	18.27	1045	22.00	1106	25.94	1165	29.99	1222	34.09	<b>1279</b>	<b>38.39</b>	<b>1336</b>	<b>42.89</b>
26044	3400	926	13.52	955	15.32	984	17.18	1012	19.07	1068	23.06	1123	27.20	1177	31.44	1231	35.86	1283	40.32	1335	44.99	1386	49.74
29108	3800	1028	18.37	1054	20.35	1080	22.39	1106	24.51	1157	28.87	1206	33.33	1255	37.97	1304	42.75	1352	47.60	1399	52.51	1446	57.62
32172	4200	1131	24.32	1155	26.52	1179	28.79	1202	31.04	1248	35.72	1293	40.54	1338	45.58	1383	50.78	1427	56.00	1470	61.24	1514	66.76

CFM	OV	10" SP		11" SP		12" SP		13" SP		14" SP		15" SP		16" SP		17" SP		18" SP		19" SP		20" SP	
		RPM	BHP	RPM	BHP	RPM	BHP	RPM	BHP	RPM	BHP	RPM	BHP	RPM	BHP	RPM	BHP	RPM	BHP	RPM	BHP	RPM	BHP
18384	2400	<b>1359</b>	<b>38.63</b>																				
19916	2600	<b>1361</b>	<b>41.06</b>	<b>1424</b>	<b>45.55</b>																		
21448	2800	<b>1373</b>	<b>44.01</b>	<b>1430</b>	<b>48.40</b>	1489	53.19	1549	58.22														
22980	3000	<b>1391</b>	<b>47.35</b>	<b>1445</b>	<b>51.88</b>	<b>1499</b>	<b>56.57</b>	<b>1553</b>	<b>61.45</b>	<b>1607</b>	<b>66.50</b>	<b>1664</b>	<b>72.04</b>										
24512	3200	<b>1412</b>	<b>50.85</b>	<b>1464</b>	<b>55.62</b>	<b>1515</b>	<b>60.42</b>	<b>1566</b>	<b>65.38</b>	<b>1616</b>	<b>70.37</b>	<b>1667</b>	<b>75.67</b>	1718	81.13	1771	86.98						
26044	3400	<b>1436</b>	<b>5</b>																				

# BC SWSI 402

Outlet Area - 9.31 ft<sup>2</sup>      Wheel Dia. - 40.25 inches      Tip Speed - 10.54 x RPM      Max. BHP = 31.67 (RPM÷1000)<sup>3</sup>

CFM	OV	0.50" SP		1" SP		1.5" SP		2" SP		3" SP		4" SP		5" SP		6" SP		7" SP		8" SP		9" SP	
		RPM	BHP	RPM	BHP	RPM	BHP	RPM	BHP	RPM	BHP	RPM	BHP	RPM	BHP	RPM	BHP	RPM	BHP	RPM	BHP	RPM	BHP
7448	800	296	0.79	390	1.55																		
8379	900	310	0.93	395	1.72																		
9310	1000	325	1.08	404	1.93	478	2.89																
11172	1200	360	1.46	428	2.42	492	3.46	553	4.58														
13034	1400	398	1.94	457	2.99	515	4.17	569	5.38	675	8.08												
14896	1600	438	2.54	491	3.72	542	4.97	592	6.32	687	9.18	779	12.33										
16758	1800	480	3.29	528	4.59	574	5.94	619	7.38	706	10.46	789	13.73	871	17.31								
18620	2000	523	4.20	566	5.58	609	7.09	650	8.62	730	11.90	807	15.41	882	19.12	955	23.02						
20482	2200	567	5.28	607	6.80	645	8.37	684	10.06	758	13.54	829	17.22	899	21.17	966	25.17	1033	29.47	1102	34.21		
22344	2400	611	6.54	648	8.17	684	9.88	719	11.64	788	15.34	855	19.26	920	23.38	984	27.71	1046	32.13	1107	36.71	1169	41.67
24206	2600	656	8.03	690	9.75	724	11.59	757	13.49	821	17.40	884	21.53	945	25.85	1005	30.38	1064	35.08	1121	39.81	1177	44.66
26068	2800	702	9.76	733	11.57	765	13.53	795	15.49	856	19.70	915	24.03	973	28.58	1029	33.25	1084	38.08	1139	43.16	1192	48.21
27930	3000	747	11.69	777	13.66	806	15.67	835	17.78	892	22.20	948	26.79	1002	31.46	1056	36.42	1108	41.44	1160	46.70	1211	52.07
31654	3400	839	16.40	866	18.62	892	20.87	918	23.21	968	27.99	1018	33.04	1067	38.20	1116	43.57	1163	48.97	1210	54.62	1257	60.49
35378	3800	932	22.32	956	24.76	979	27.20	1003	29.81	1048	34.99	1093	40.46	1138	46.16	1182	51.92	1226	57.87	1269	63.91	1311	70.02
39102	4200	1025	29.52	1047	32.22	1068	34.90	1089	37.65	1131	43.35	1173	49.37	1213	55.38	1253	61.58	1293	67.93	1333	74.46	1372	81.01

CFM	OV	10" SP		11" SP		12" SP		13" SP		14" SP		15" SP		16" SP		17" SP		18" SP		19" SP		20" SP	
		RPM	BHP	RPM	BHP	RPM	BHP	RPM	BHP	RPM	BHP	RPM	BHP	RPM	BHP	RPM	BHP	RPM	BHP	RPM	BHP	RPM	BHP
22344	2400	1233	47.03																				
24206	2600	1234	49.89	1292	55.45																		
26068	2800	1245	53.49	1297	58.86	1350	64.62	1404	70.67														
27930	3000	1261	57.51	1310	63.01	1359	68.72	1408	74.65	1458	80.96	1509	87.57										
29792	3200	1280	61.76	1327	67.53	1374	73.48	1420	79.46	1466	85.65	1512	92.05	1558	98.64	1606	105.73						
31654	3400	1302	66.30	1347	72.31	1392	78.50	1436	84.70	1479	90.90	1522	97.27	1566	104.03	1609	110.79	1653	117.94	1698	125.42	1743	133.04
33516	3600	1327	71.25	1370	77.45	1413	83.85	1455	90.26	1497	96.83	1538	103.36	1579	110.06	1619	116.73	1660	123.78	1701	131.03	1743	138.69
35378	3800	1353	76.35	1394	82.71	1435	89.27	1476	96.01	1516	102.74	1556	109.63	1596	116.68	1634	123.44	1673	130.58	1712	137.90	1750	145.14
37240	4000	1381	81.83	1421	88.51	1460	95.19	1499	102.06	1538	109.10	1577	116.33	1615	123.50	1652	130.59	1690	138.05	1726	145.18	1763	152.70
39102	4200	1411	87.76	1449	94.54	1487	101.52	1525	108.68	1562	115.81	1599	123.11	1636	130.59	1672	137.98	1708	145.52	1744	153.19	1779	160.74
42826	4600	1474	100.63	1510	107.93	1545	115.21	1581	122.92	1615	130.35	1650	138.18	1684	145.94	1718	153.86	1752	161.94	1785	169.89	1819	178.28
46550	5000	1542	115.24	1576	123.08	1609	130.85	1642	138.78	1674	146.63	1706	154.66	1739	163.14	1770	171.21	1802	179.73	1833	188.10	1865	196.93

MAXIMUM RPM:    Class I — 903      Class II — 1163      Class III — 1566      Class IV — 1706

# BC SWSI 445

Outlet Area - 11.39 ft<sup>2</sup>      Wheel Dia. - 44.50 inches      Tip Speed - 11.65 x RPM      Max. BHP = 52.32 (RPM÷1000)<sup>3</sup>

CFM	OV	0.50" SP		1" SP		1.5" SP		2" SP		3" SP		4" SP		5" SP		6" SP		7" SP		8" SP		9" SP	
		RPM	BHP	RPM	BHP	RPM	BHP	RPM	BHP	RPM	BHP	RPM	BHP	RPM	BHP	RPM	BHP	RPM	BHP	RPM	BHP	RPM	BHP
9112	800	268	0.97	352	1.88																		
10251	900	280	1.13	357	2.10																		
11390	1000	294	1.32	365	2.36	432	3.52																
13668	1200	325	1.78	387	2.95	445	4.24	501	5.62														
15946	1400	360	2.38	414	3.68	466	5.10	515	6.59	611	9.90												
18224	1600	396	3.10	444	4.54	491	6.10	536	7.75	621	11.21	705	15.11										
20502	1800	434	4.02	478	5.62	520	7.30	560	9.02	639	12.81	714	16.82	788	21.18								
22780	2000	473	5.13	513	6.87	551	8.67	588	10.54	661	14.59	730	18.85	798	23.40	864	28.18						
25058	2200	513	6.46	549	8.30	584	10.26	619	12.32	686	16.58	750	21.07	813	25.87	874	30.81	935	36.12	996	41.75		
27336	2400	553	8.01	586	9.97	619	12.09	651	14.28	713	18.77	774	23.61	833	28.67	890	33.88	946	39.27	1001	44.86	1057	50.91
29614	2600	594	9.84	625	11.96	655	14.17	685	16.51	743	21.30	800	26.37	855	31.63	909	37.14	962	42.84	1014	48.69	1065	54.68
31892	2800	635	11.94	664	14.20	692	16.54	720	19.01	774	24.06	828	29.41	880	34.93	931	40.69	981	46.64	1030	52.73	1079	59.10
34170	3000	676	14.31	703	16.71	730	19.23	756	21.80	807	27.15	858	32.80	907	38.54	955	44.50	1003	50.78	1050	57.22	1096	63.78
38726	3400	760	20.14	784	22.82	807	25.53	830	28.33	876	34.27	921	40.42	966	46.82	1010	53.36	1053	60.05	1095	66.87	1137	73.97
43282	3800	844	27.38	865	30.29	886	33.30	907	36.40	949	42.91	990	49.66	1030	56.54	1070	63.62	1109	70.76	1148	78.16	1186	85.65
47838	4200	928	36.19	948	39.50	967	42.79	986	46.15	1024	53.14	1061	60.34	1098	67.84	1134	75.40	1170	83.14	1206	91.09	1242	99.27

CFM	OV	10" SP		11" SP		12" SP		13" SP		14" SP		15" SP		16" SP		17" SP		18" SP		19" SP		20" SP	
		RPM	BHP	RPM	BHP	RPM	BHP	RPM	BHP	RPM	BHP	RPM	BHP	RPM	BHP	RPM	BHP	RPM	BHP	RPM	BHP	RPM	BHP
27336	2400	1115	57.49																				
29614	2600	1116	60.99	1168	67.72																		
31892	2800	1126	65.39	1173	71.97	1221	79.01	1270	86.46														
34170	3000	1141	70.41	1185	77.08	1229	84.00	1274	91.40	1318	98.85	1364	106.91										
36448	3200	1158	75.57	1201	82.72	1243	89.90	1284	97.09</														



# BC SWSI 490

Outlet Area - 13.80 ft<sup>2</sup>

Wheel Dia. - 49.00 inches

Tip Speed - 12.83 x RPM

Max. BHP = 84.69 (RPM÷1000)<sup>3</sup>

CFM	OV	0.50" SP		1" SP		1.5" SP		2" SP		3" SP		4" SP		5" SP		6" SP		7" SP		8" SP		9" SP	
		RPM	BHP	RPM	BHP	RPM	BHP	RPM	BHP	RPM	BHP	RPM	BHP	RPM	BHP	RPM	BHP	RPM	BHP	RPM	BHP	RPM	BHP
11040	800	243	1.17	320	2.29																		
12420	900	254	1.36	324	2.54																		
13800	1000	267	1.60	332	2.87	392	4.26																
16560	1200	295	2.15	351	3.56	404	5.13	455	6.82														
19320	1400	327	2.88	376	4.46	423	6.18	468	8.01	554	11.94												
22080	1600	360	3.78	403	5.50	446	7.40	486	9.35	564	13.59												
24840	1800	394	4.87	433	6.77	472	8.84	509	10.97	580	15.51	640	18.28										
27600	2000	430	6.24	465	8.28	500	10.49	534	12.78	600	17.67	648	20.34	716	25.71								
30360	2200	466	7.84	498	10.03	530	12.41	562	14.92	623	20.10	681	25.53	739	31.44	794	37.38	849	43.75	905	50.68		
33120	2400	502	9.70	532	12.08	562	14.65	591	17.29	648	22.81	703	28.63	756	34.69	808	41.03	859	47.58	909	54.35	960	
35880	2600	539	11.90	567	14.46	595	17.20	621	19.92	674	25.74	726	31.90	776	38.28	825	44.93	874	51.99	921	59.03	967	
38640	2800	576	14.42	602	17.14	628	20.01	653	22.95	703	29.18	751	35.53	799	42.32	845	49.24	891	56.55	936	64.04	979	
41400	3000	614	17.36	638	20.21	662	23.21	686	26.37	733	32.94	778	39.59	823	46.61	867	53.89	911	61.59	953	69.24	995	
46920	3400	690	24.39	711	27.56	733	30.97	754	34.39	795	41.47	836	48.93	877	56.71	917	64.64	956	72.73	994	80.96	1032	
52440	3800	766	33.13	785	36.65	805	40.44	824	44.19	861	51.88	898	60.00	935	68.46	971	76.97	1007	85.76	1042	94.61	1077	
57960	4200	842	43.76	860	47.74	878	51.85	895	55.88	929	64.24	963	73.04	997	82.22	1030	91.46	1063	100.93	1095	110.36	1127	

CFM	OV	10" SP		11" SP		12" SP		13" SP		14" SP		15" SP		16" SP		17" SP		18" SP		19" SP		20" SP	
		RPM	BHP	RPM	BHP	RPM	BHP	RPM	BHP	RPM	BHP	RPM	BHP	RPM	BHP	RPM	BHP	RPM	BHP	RPM	BHP	RPM	BHP
33120	2400	1012	69.54																				
35880	2600	1013	73.80	1061	82.13																		
38640	2800	1022	79.12	1066	87.40																		
41400	3000	1036	85.29	1076	93.38	1116	101.77	1157	110.77	1197	119.81	1239	129.64										
44160	3200	1052	91.69	1090	100.07	1129	109.01	1166	117.65	1204	126.88	1242	136.43	1280	146.28	1319	156.63						
46920	3400	1070	98.41	1107	107.33	1144	116.53	1180	125.68	1215	134.76	1251	144.44	1286	154.06	1322	164.33	1358	174.89	1394	185.59	1432	
49680	3600	1090	105.59	1125	114.68	1160	124.06	1195	133.72	1229	143.27	1263	153.07	1297	163.12	1330	173.05	1364	183.64	1397	194.10	1431	
52440	3800	1111	113.04	1146	122.89	1179	132.39	1213	142.50	1246	152.54	1278	162.43	1311	172.93	1343	183.28	1374	193.44	1406	204.27	1438	
55200	4000	1135	121.48	1167	131.09	1200	141.33	1232	151.51	1264	161.95	1295	172.26	1326	182.80	1357	193.55	1388	204.52	1418	215.27	1448	
57960	4200	1159	130.06	1191	140.38	1222	150.65	1253	161.20	1283	171.62	1314	182.69	1344	193.61	1374	204.77	1403	215.68	1433	227.26	1462	
63480	4600	1211	149.21	1241	160.21	1270	171.11	1298	181.89	1327	193.36	1355	204.64	1383	216.16	1411	227.93	1439	239.94	1466	251.66	1494	
69000	5000	1267	170.93	1294	182.17	1322	194.07	1348	205.33	1375	217.29	1402	229.53	1428	241.55	1454	253.79	1480	266.26	1506	278.96	1532	

MAXIMUM RPM: Class I — 742 Class II — 956 Class III — 1286 Class IV — 1401

# BC SWSI 542

Outlet Area - 16.92 ft<sup>2</sup>

Wheel Dia. - 54.25 inches

Tip Speed - 14.20 x RPM

Max. BHP = 140.88 (RPM÷1000)<sup>3</sup>

CFM	OV	0.50" SP		1" SP		1.5" SP		2" SP		3" SP		4" SP		5" SP		6" SP		7" SP		8" SP		9" SP	
		RPM	BHP	RPM	BHP	RPM	BHP	RPM	BHP	RPM	BHP	RPM	BHP	RPM	BHP	RPM	BHP	RPM	BHP	RPM	BHP	RPM	BHP
13536	800	220	1.44	289	2.80																		
15228	900	230	1.68	293	3.13																		
16920	1000	241	1.95	300	3.52	354	5.22																
20304	1200	267	2.65	317	4.37	365	6.29	411	8.36														
23688	1400	295	3.52	339	5.44	382	7.57	423	9.83	501	14.69												
27072	1600	325	4.62	364	6.74	403	9.08	439	11.46	510	16.72	578	22.41										
30456	1800	356	5.97	392	8.35	426	10.81	460	13.46	524	19.02	586	25.03	646	31.42								
33840	2000	388	7.62	420	10.15	452	12.90	482	15.63	542	21.66	599	28.03	654	34.68	709	41.92						
37224	2200	421	9.62	450	12.32	479	15.24	507	18.22	562	24.55	616	31.44	667	38.46	717	45.80	767	53.67	817	62.03		
40608	2400	454	11.94	481	14.85	508	18.00	534	21.22	585	27.92	635	35.10	683	42.56	730	50.34	776	58.36	821	66.62	867	
43992	2600	487	14.61	512	17.71	537	21.03	561	24.43	609	31.59	656	39.14	701	46.94	746	55.27	789	63.63	832	72.41	873	
47376	2800	521	17.75	544	21.03	567	24.50	590	28.16	635	35.77	679	43.68	722	51.95	764	60.54	805	69.38	845	78.39	885	
50760	3000	555	21.33	577	24.87	598	28.46	620	32.38	662	40.36	703	48.59	744	57.28	784	66.29	822	75.26	861	84.95	899	
57528	3400	623	29.87	643	33.91	662	37.95	681	42.14	719	51.02	756	60.20	792	69.48	828	79.16	863	89.01	898	99.31	932	
64296	3800	692	40.63	709	44.92	727	49.54	744	54.11	778	63.67	812	73.79	845	84.06	877	94.33	910	105.27	941	115.91	973	
71064	4200	761	53.74	777	58.57	793	63.54	809	68.65	840	78.99	870	89.58	900	100.61	930	111.99	960	123.67	989	135.27	1018	

CFM	OV	10" SP		11" SP		12" SP		13" SP		14" SP		15" SP		16" SP		17" SP		18" SP		19" SP		20" SP	
		RPM	BHP	RPM	BHP	RPM	BHP	RPM	BHP	RPM	BHP	RPM	BHP	RPM	BHP	RPM	BHP	RPM	BHP	RPM	BHP	RPM	BHP
40608	2400	914	85.24																				
43992	2600	915	90.49	958	100.59																		
47376	2800	924	97.28	962	106.86	1002	117.55	1042	128.54														
50760	3000	936	104.64	972	114.52	1008	124.77	1045	135.79	1082	147.22	1119	158.89										
54144	3200	950	112.33	985	122.86	1019	133.34	1053	144.16	1087	155.34	1122	167.35	1156	179.27	1191	191.86						
57528	3400	966	120.46	1000	131.62	1033	142.73	1065	153.72	1098	165.46	1130	177.10	1162	189.09	1194	201.43	1226	214.10	1260	228.02	1293	
60912	3600	984	129.23	1016	140.53	1048	152.20	1080	164.22	1111	176.08	1141	187.76	1171	199.72	1202	212.52	1232	225.13	1262	238.07	1293	
64296	3800	1004	138.78	1035	150.60	1065	162.33	1095	174.40	1125	186.79	1155	199.48	1184	211.93	1213	224.67	1241	237.13	1270	250.46	1299	
67680	4000	1025	148.84	1054	160.67	1084	173.31	1113	185.84	1141	198.17	1170	211.34	1198	224.27	1226	237.46	1254	250.92	1281	264.05	1308	
71064	4200	1047	159.50	1075	171.73	1104	184.80	1132	197.74	1159	210.46	1187	224.05	1214	237.38	1241	251.00	1268	264.89	1294	278.39	1320	
77832	4600	1094	183.00	1121	196.44	1147	209.70	1173	223.31	1199	237.27	1224	250.93	1250	265.52	1275	279.77	1300	294.30	1325	309.12	1349	
84600	5000	1145	209.85	1169	223.42	1194	237.84	1218	251.97	1242	266.39	1266	281.14	1290	296.22	1314	311.60	1337	326.56	1360	341.77	1384	

# BC SWSI 600

Outlet Area - 20.70 ft<sup>2</sup>      Wheel Dia. - 60.00 inches      Tip Speed - 15.71 x RPM      Max. BHP = 233.14 (RPM ÷ 1000)<sup>3</sup>

CFM	OV	0.50" SP		1" SP		1.5" SP		2" SP		3" SP		4" SP		5" SP		6" SP		7" SP		8" SP		9" SP	
		RPM	BHP	RPM	BHP	RPM	BHP	RPM	BHP	RPM	BHP	RPM	BHP	RPM	BHP	RPM	BHP	RPM	BHP	RPM	BHP	RPM	BHP
16560	800	199	1.77	261	3.41																		
18630	900	208	2.06	265	3.83																		
20700	1000	218	2.39	271	4.30	320	6.38																
24840	1200	241	3.23	287	5.36	330	7.70	371	10.17														
28980	1400	267	4.32	307	6.68	345	9.23	382	11.99	453	17.98												
33120	1600	294	5.66	330	8.31	364	11.07	397	14.02	461	20.43	523	27.48										
37260	1800	322	7.31	354	10.18	385	13.20	416	16.48	474	23.30	530	30.65	584	38.41								
41400	2000	351	9.34	380	12.43	408	15.69	436	19.15	490	26.49	542	34.37	591	42.36	641	51.26						
45540	2200	380	11.70	407	15.08	433	18.63	459	22.38	509	30.18	557	38.46	603	47.03	648	55.95	693	65.52	739	75.98		
49680	2400	410	14.55	435	18.18	459	21.97	483	25.98	529	34.16	574	42.91	618	52.17	660	61.56	702	71.50	743	81.73	784	92.55
53820	2600	440	17.83	463	21.68	486	25.80	508	30.01	551	38.72	593	47.85	634	57.47	674	67.45	714	78.04	752	88.48	790	99.44
57960	2800	471	21.71	492	25.75	513	30.03	534	34.55	574	43.72	614	53.45	653	63.60	690	73.81	728	84.92	764	95.89	800	107.31
62100	3000	502	26.12	521	30.30	541	34.87	560	39.48	599	49.48	636	59.54	673	70.16	708	80.80	744	92.36	778	103.72	813	116.00
70380	3400	563	36.48	581	41.39	599	46.52	616	51.62	650	62.39	683	73.46	716	84.96	749	96.97	781	109.17	812	121.51	843	134.33
78660	3800	626	49.78	642	55.19	657	60.51	673	66.27	704	78.07	734	90.19	764	102.81	793	115.41	822	128.40	851	141.88	880	155.90
86940	4200	688	65.71	703	71.79	717	77.72	731	83.81	759	96.43	787	109.74	814	123.18	841	137.05	868	151.28	894	165.34	921	180.38

CFM	OV	10" SP		11" SP		12" SP		13" SP		14" SP		15" SP		16" SP		17" SP		18" SP		19" SP		20" SP	
		RPM	BHP	RPM	BHP	RPM	BHP	RPM	BHP	RPM	BHP	RPM	BHP	RPM	BHP	RPM	BHP	RPM	BHP	RPM	BHP	RPM	BHP
49680	2400	827	104.51																				
53820	2600	828	110.97	866	122.97																		
57960	2800	835	118.81	870	130.82	906	143.82	942	157.18														
62100	3000	846	127.87	879	140.17	912	152.93	945	166.19	978	179.94	1012	194.52										
66240	3200	859	137.43	891	150.49	922	163.47	952	176.31	983	190.13	1014	204.44	1045	219.18	1077	234.81						
70380	3400	874	147.65	904	160.92	934	174.60	963	188.08	992	201.94	1021	216.21	1050	230.89	1079	246.03	1109	262.27	1139	278.77	1169	295.57
74520	3600	890	158.24	919	172.12	948	186.44	976	200.58	1004	215.06	1032	229.92	1059	244.48	1086	259.41	1114	275.46	1141	291.20	1169	308.11
78660	3800	908	169.89	936	184.33	963	198.62	990	213.29	1017	228.37	1044	243.80	1070	258.87	1097	275.02	1122	290.03	1148	306.16	1174	322.67
82800	4000	927	182.20	953	196.54	980	211.93	1006	227.10	1032	242.66	1058	258.62	1083	274.20	1109	290.87	1134	307.09	1158	322.81	1183	339.70
86940	4200	947	195.31	972	210.08	998	225.92	1023	241.52	1048	257.50	1073	273.88	1098	290.65	1122	306.98	1146	323.62	1170	340.56	1194	357.82
95220	4600	989	223.74	1013	239.88	1037	256.45	1061	273.48	1084	290.16	1107	307.20	1130	324.61	1153	342.40	1175	359.63	1198	378.11	1220	395.99
103500	5000	1035	256.49	1057	273.32	1080	291.28	1101	307.98	1123	325.88	1145	344.20	1167	362.93	1188	381.10	1209	399.59	1230	418.41	1251	437.57

MAXIMUM RPM:    Class I — 606            Class II — 780            Class III — 1050          Class IV — 1146

# BC SWSI 660

Outlet Area - 25.04 ft<sup>2</sup>      Wheel Dia. - 66.00 inches      Tip Speed - 17.28 x RPM      Max. BHP = 375.47 (RPM ÷ 1000)<sup>3</sup>

CFM	OV	0.50" SP		1" SP		1.5" SP		2" SP		3" SP		4" SP		5" SP		6" SP		7" SP		8" SP		9" SP	
		RPM	BHP	RPM	BHP	RPM	BHP	RPM	BHP	RPM	BHP	RPM	BHP	RPM	BHP	RPM	BHP	RPM	BHP	RPM	BHP	RPM	BHP
20040	800	181	2.14	238	4.17																		
22545	900	189	2.49	241	4.64																		
25050	1000	198	2.89	246	5.18	291	7.73																
30060	1200	219	3.90	261	6.50	300	9.31	338	12.39														
35070	1400	243	5.24	279	8.08	314	11.20	347	14.47	412	21.78												
40080	1600	267	6.83	300	10.06	331	13.41	361	16.98	419	24.71	475	33.15										
45090	1800	293	8.87	322	12.34	350	15.98	378	19.91	431	28.22	481	36.90	531	46.51								
50100	2000	319	11.29	346	15.12	371	19.00	397	23.28	445	31.96	492	41.41	538	51.46	583	62.12						
55110	2200	346	14.23	370	18.24	394	22.60	417	27.02	462	36.34	506	46.44	548	56.85	589	67.67	630	79.28	672	92.02		
60120	2400	373	17.64	395	21.92	417	26.53	439	31.42	481	41.36	522	51.97	561	62.86	600	74.50	638	86.45	675	98.70	713	112.13
65130	2600	400	21.57	421	26.24	442	31.26	462	36.36	501	46.87	539	57.87	576	69.41	613	81.73	649	94.39	684	107.24	718	120.24
70140	2800	428	26.23	447	31.10	467	36.48	485	41.69	522	52.96	558	64.61	593	76.71	628	89.62	661	102.38	695	116.26	727	129.71
75150	3000	456	31.52	474	36.75	492	42.24	510	48.03	544	59.69	578	71.97	611	84.56	644	97.93	676	111.57	708	125.90	739	140.32
85170	3400	512	44.18	528	50.03	544	56.12	560	62.45	591	75.52	621	88.92	651	102.84	681	117.38	710	132.10	738	146.92	767	162.95
95190	3800	569	60.20	583	66.56	598	73.48	612	80.26	640	94.46	667	109.00	694	124.11	721	139.69	748	155.82	774	171.91	800	188.64
105210	4200	626	79.72	639	86.82	652	94.12	665	101.61	690	116.68	715	132.52	740	149.05	765	166.13	789	182.98	813	200.26	837	218.05

CFM	OV	10" SP		11" SP		12" SP		13" SP		14" SP		15" SP		16" SP		17" SP		18" SP		19" SP		20" SP	
		RPM	BHP	RPM	BHP	RPM	BHP	RPM	BHP	RPM	BHP	RPM	BHP	RPM	BHP	RPM	BHP	RPM	BHP	RPM	BHP	RPM	BHP
60120	2400	752	126.56																				
65130	2600	752	133.90	788	149.22																		
70140	2800	759	143.72	791	158.35	823	173.63	856	189.97														
75150	3000	769	154.68	799	169.55	829	185.00	859	201.04	889	217.67	920	235.39										
80160	3200	781	166.36	810	182.11	838																	

# BC SWSI 730

Outlet Area - 30.63 ft<sup>2</sup> Wheel Dia. - 73.00 inches Tip Speed - 19.11 x RPM Max. BHP = 621.54 (RPM ÷ 1000)<sup>3</sup>

CFM	OV	0.50" SP		1" SP		1.5" SP		2" SP		3" SP		4" SP		5" SP		6" SP		7" SP		8" SP		9" SP	
		RPM	BHP	RPM	BHP	RPM	BHP	RPM	BHP	RPM	BHP	RPM	BHP	RPM	BHP	RPM	BHP	RPM	BHP	RPM	BHP	RPM	BHP
24512	800	163	2.59	215	5.09																		
27576	900	171	3.05	218	5.69																		
30640	1000	179	3.53	223	6.38	263	9.44																
36768	1200	198	4.77	236	7.95	271	11.36	305	15.07														
42896	1400	219	6.35	252	9.85	284	13.72	314	17.75	372	26.54												
49024	1600	242	8.42	271	12.27	299	16.36	326	20.70	379	30.27	430	40.71										
55152	1800	265	10.87	291	15.07	317	19.65	342	24.41	389	34.34	435	45.17	480	56.86								
61280	2000	288	13.75	312	18.35	336	23.37	359	28.50	403	39.29	445	50.71	486	62.79	527	75.95						
67408	2200	313	17.44	335	22.42	356	27.60	377	33.06	418	44.56	457	56.63	496	69.78	533	83.01	570	97.19	607	112.25		
73536	2400	337	21.54	357	26.79	377	32.46	397	38.46	435	50.64	472	63.60	508	77.25	543	91.40	577	105.85	610	120.57	644	136.76
79664	2600	362	26.47	381	32.20	399	38.07	417	44.26	453	57.36	487	70.66	521	85.02	554	99.86	586	115.01	618	130.92	649	146.98
85792	2800	387	32.10	404	38.01	422	44.56	439	51.18	472	64.81	505	79.28	536	93.77	567	109.18	598	125.48	628	141.98	657	158.46
91920	3000	412	38.49	429	45.10	445	51.74	461	58.72	492	73.10	523	88.27	553	103.78	582	119.65	611	136.37	640	153.93	668	171.54
104176	3400	463	54.09	478	61.45	492	68.73	506	76.27	534	92.22	562	109.10	589	126.09	615	143.11	642	161.67	667	179.54	693	198.95
116432	3800	514	73.46	527	81.39	540	89.57	553	98.02	578	115.18	603	133.32	628	152.23	652	171.01	676	190.39	700	210.51	723	230.49
128688	4200	566	97.54	578	106.37	589	114.87	601	124.17	624	142.86	647	162.55	669	182.31	691	202.67	713	223.53	735	244.96	757	267.03

CFM	OV	10" SP		11" SP		12" SP		13" SP		14" SP		15" SP		16" SP		17" SP		18" SP		19" SP		20" SP	
		RPM	BHP	RPM	BHP	RPM	BHP	RPM	BHP	RPM	BHP	RPM	BHP	RPM	BHP	RPM	BHP	RPM	BHP	RPM	BHP	RPM	BHP
73536	2400	680	154.88																				
79664	2600	680	163.87	712	182.20																		
85792	2800	686	175.64	715	193.58																		
91920	3000	695	189.00	722	207.08	744	212.32	774	232.44														
						749	225.84	776	245.32	804	266.51	832	288.16										
98048	3200	706	203.41	732	222.47	758	242.15	783	261.51	808	281.50	833	302.15	859	324.54	885	347.32						
104176	3400	718	218.23	743	238.19	768	258.78	792	278.93	816	299.64	839	319.83	863	341.76	887	364.36	911	387.57	936	412.42	961	437.75
110304	3600	732	234.71	755	254.43	779	275.79	802	296.69	825	318.11	848	340.07	871	362.62	893	384.49	915	406.92	938	431.31	961	456.32
116432	3800	746	251.17	769	272.53	792	294.55	814	316.08	836	338.17	858	360.78	880	383.90	901	406.23	923	430.44	944	453.81	965	477.73
122560	4000	762	269.79	784	291.73	805	313.15	827	336.35	848	358.92	869	382.05	890	405.70	911	429.84	932	454.49	952	478.17	972	502.33
128688	4200	778	288.71	799	311.08	820	334.09	841	357.73	861	380.68	882	405.53	902	429.57	922	454.13	942	479.17	962	504.67	981	529.05
140944	4600	813	331.35	833	355.60	852	379.17	872	404.75	891	429.57	910	454.94	929	480.88	947	505.76	966	532.75	984	558.58	1003	586.62
153200	5000	851	380.10	869	404.91	887	430.20	905	456.00	923	482.37	941	509.35	959	536.94	976	563.36	994	592.03	1011	619.43	1028	647.30

MAXIMUM RPM: Class I — 498 Class II — 641 Class III — 863 Class IV — 940

# BC SWSI 807

Outlet Area - 37.49 ft<sup>2</sup> Wheel Dia. - 80.75 inches Tip Speed - 21.14 x RPM Max. BHP = 1029.2 (RPM ÷ 1000)<sup>3</sup>

CFM	OV	0.50" SP		1" SP		1.5" SP		2" SP		3" SP		4" SP		5" SP		6" SP		7" SP		8" SP		9" SP	
		RPM	BHP	RPM	BHP	RPM	BHP	RPM	BHP	RPM	BHP	RPM	BHP	RPM	BHP	RPM	BHP	RPM	BHP	RPM	BHP	RPM	BHP
29992	800	148	3.21	194	6.19																		
33741	900	154	3.69	197	6.95																		
37490	1000	162	4.34	201	7.74	238	11.59																
44988	1200	179	5.84	213	9.68	245	13.90	276	18.50														
52486	1400	198	7.78	228	12.08	257	16.84	284	21.75	336	32.39												
59984	1600	218	10.19	245	15.02	270	19.95	295	25.41	342	36.83	388	49.53										
67482	1800	239	13.20	263	18.43	286	23.90	309	29.82	352	42.14	393	55.17	434	69.61								
74980	2000	261	16.95	282	22.44	303	28.38	324	34.69	364	47.95	402	61.92	439	76.64	476	92.68						
82478	2200	283	21.34	302	27.20	322	33.83	341	40.51	378	54.57	414	69.73	448	85.15	482	101.66	515	118.71	549	137.54		
89976	2400	305	26.45	323	32.86	341	39.78	359	47.10	393	61.84	426	77.44	459	94.38	491	111.91	521	129.05	552	147.96	583	168.03
97474	2600	327	32.31	344	39.25	361	46.69	377	54.16	409	69.91	441	86.90	471	104.03	501	122.32	530	140.92	559	160.46	587	180.11
104972	2800	350	39.33	366	46.80	381	54.31	397	62.69	427	79.47	456	96.66	485	115.05	513	133.92	541	153.88	568	173.97	594	193.95
112470	3000	373	47.30	387	54.83	402	63.17	416	71.46	445	89.58	472	107.45	500	127.04	526	146.28	553	167.44	578	187.78	604	210.01
127466	3400	419	66.39	432	75.13	445	84.22	458	93.67	483	113.02	508	133.45	532	153.87	556	175.13	580	197.42	603	219.70	626	242.87
142462	3800	465	90.08	477	99.95	488	109.48	500	119.99	523	141.32	545	163.02	567	185.56	589	208.79	611	232.83	632	256.58	654	282.54
157458	4200	511	118.88	522	129.76	533	140.97	543	151.66	564	174.70	585	199.00	605	223.31	625	248.37	645	274.06	665	300.46	684	326.24

CFM	OV	10" SP		11" SP		12" SP		13" SP		14" SP		15" SP		16" SP		17" SP		18" SP		19" SP		20" SP	
		RPM	BHP	RPM	BHP	RPM	BHP	RPM	BHP	RPM	BHP	RPM	BHP	RPM	BHP	RPM	BHP	RPM	BHP	RPM	BHP	RPM	BHP
89976	2400	614	188.82																				
97474	2600	615	200.76	644	223.28																		
104972	2800	620	214.74	647	237.55	673	260.26	700	284.76														
112470	3000	629	232.03	653	253.72	677	276.19	702	300.78	727	326.31	752	352.38										
119968	3200	638	248.60	662	272.52	685	295.97	708	320.18	731	345.21	753	369.63	777	397.78	800	424.87						
127466	3400	649	266.92	672	291.85	694	316.24	716	341.31	737	365.62	759	392.15	780	417.89	802	446.04	824	474.97	846	504.33	869	536.05
134964	3600	661	286.22	683	311.95	704	337.11	725	362.98	746	389.51	767	416.74	787	443.01	807	469.94	828	499.38	848	527.78	869	558.79
142462	3800	675	308.15	695	333.18	716	360.43	736	386.95	756	414.17	776	442.04	795	468.78	815	497.92	834	525.89	853	554.50	872	583.77
149960	4000	689	330.31	708	355.82	728	383.58	748	412.17	767	439.84	786	468.19	805	497.18	824	526.77	842	555.01	861	585.83	879	615.24
157458	4200	703	352.77	723	381.72	741	408.30	760	437.23	779	466.94	797	495.54	816	526.72	834	556.64	852	587.15	869	616.08	887	647.67
172454	4600	735	405.48	753	435.01	771	465.35	788	494.67	805	524.67	822	555.32</										



# BC DWDI 122

Outlet Area - 1.55 ft<sup>2</sup>

Wheel Dia. - 12.25 inches

Tip Speed - 3.21 x RPM

Max. BHP = 0.136 (RPM÷1000)<sup>3</sup>

CFM	OV	0.5" SP		1" SP		2" SP		3" SP		4" SP		5" SP		6" SP		8" SP		10" SP		12" SP		14" SP	
		RPM	BHP	RPM	BHP	RPM	BHP	RPM	BHP	RPM	BHP	RPM	BHP	RPM	BHP	RPM	BHP	RPM	BHP	RPM	BHP	RPM	BHP
1240	800	1046	0.15	1363	0.31																		
1550	1000	1153	0.21	1417	0.37																		
1860	1200	1267	0.28	1514	0.46	1938	0.91	2335	1.48	2671	2.09												
2170	1400	1393	0.37	1622	0.58	<u>1997</u>	<u>1.04</u>	2363	1.63	2699	2.30	2994	3.00										
2480	1600	1528	0.48	1734	0.71	2092	1.21	<u>2402</u>	<u>1.78</u>	2727	2.50	3022	3.26	3289	4.05								
2790	1800	1670	0.63	1854	0.87	2196	1.42	2485	2.01	2761	2.68	3050	3.50	3318	4.36	3791	6.13						
3100	2000	1815	0.80	1983	1.06	2305	1.66	2583	2.29	2833	2.96	3084	3.73	3345	4.64	3820	6.55	4237	8.53	4617	10.61		
3410	2200	1964	1.00	2118	1.29	2417	1.92	2688	2.60	2927	3.31	<u>3151</u>	<u>4.07</u>	3381	4.93	3849	6.95	4265	9.05	4643	11.25	4991	13.51
3720	2400	2115	1.24	2258	1.56	2533	2.21	2796	2.95	3029	3.71	3244	4.50	3448	5.33	3875	7.30	4295	9.57	4671	11.87	5018	14.26
4030	2600	2268	1.52	2400	1.86	2657	2.55	2907	3.33	3136	4.14	3343	4.97	3540	5.83	<u>3919</u>	<u>7.72</u>	4321	10.02	4701	12.49	5046	14.99
4340	2800	2422	1.84	2546	2.20	2786	2.94	3020	3.75	3245	4.61	3448	5.49	3638	6.39	<u>3994</u>	<u>8.29</u>	4355	10.49	4727	13.04	5076	15.71
4650	3000	2578	2.20	2694	2.59	2920	3.38	3139	4.21	3355	5.12	3556	6.06	3742	7.00	4086	8.97	<u>4412</u>	<u>11.09</u>	4757	13.58	5102	16.35
4960	3200	2735	2.62	2844	3.03	3057	3.87	3264	4.73	3468	5.67	3666	6.66	3849	7.66	4184	9.71	<u>4497</u>	<u>11.88</u>	<u>4805</u>	<u>14.24</u>	5131	16.98
5270	3400	2893	3.08	2995	3.52	3197	4.41	3393	5.31	3586	6.28	3777	7.31	3958	8.37	4287	10.51	4590	12.74	<u>4879</u>	<u>15.10</u>	<u>5174</u>	<u>17.70</u>
5890	3800	3210	4.18	3302	4.67	3484	5.67	3662	6.66	3836	7.66	4008	8.77	4180	9.92	4501	12.28	4792	14.68	5065	17.16	<u>5327</u>	<u>19.76</u>
6510	4200	3529	5.53	3613	6.07	3778	7.16	3941	8.27	4100	9.38	4258	10.51	4414	11.71	4721	14.26	5006	16.88	5269	19.53		

MAXIMUM RPM: Class I — 3196 Class II — 4168 Class III — 5500 Selections above 4000 RPM not recommended. Consult factory.

# BC DWDI 135

Outlet Area - 1.89 ft<sup>2</sup>

Wheel Dia. - 13.50 inches

Tip Speed - 3.53 x RPM

Max. BHP = 0.221 (RPM÷1000)<sup>3</sup>

CFM	OV	0.5" SP		1" SP		2" SP		3" SP		4" SP		5" SP		6" SP		8" SP		10" SP		12" SP		14" SP	
		RPM	BHP	RPM	BHP	RPM	BHP	RPM	BHP	RPM	BHP	RPM	BHP	RPM	BHP	RPM	BHP	RPM	BHP	RPM	BHP	RPM	BHP
1512	800	951	0.19	1238	0.38																		
1890	1000	1048	0.25	1287	0.45																		
2268	1200	1152	0.34	1377	0.57	1733	1.00	2095	1.61														
2646	1400	1267	0.45	1475	0.70	<u>1814</u>	<u>1.26</u>	2145	1.98	2450	2.80	2717	3.65	2961	4.54								
3024	1600	1391	0.59	1577	0.87	1901	1.48	<u>2182</u>	<u>2.17</u>	2475	3.04	2743	3.97	2985	4.92								
3402	1800	1520	0.77	1687	1.06	1997	1.74	2258	2.46	<u>2507</u>	<u>3.27</u>	2769	4.26	3012	5.31	3441	7.46						
3780	2000	1652	0.98	1805	1.30	2096	2.02	2347	2.79	<u>2574</u>	<u>3.62</u>	2800	4.55	3036	5.64	3467	7.97	3846	10.39	4190	12.91		
4158	2200	1788	1.23	1928	1.58	2197	2.34	2443	3.18	2660	4.04	2863	4.96	3069	5.99	3493	8.45	3871	11.02	4214	13.69	4530	16.45
4536	2400	1926	1.52	2055	1.91	2304	2.71	2542	3.60	2753	4.53	2948	5.49	3132	6.49	3518	8.89	3898	11.64	4239	14.45	4554	17.35
4914	2600	2065	1.86	2185	2.28	2417	3.12	2643	4.07	2850	5.06	3039	6.07	3216	7.11	3559	9.40	3922	12.19	4267	15.21	4580	18.25
5292	2800	2206	2.26	2318	2.70	2535	3.60	2747	4.58	2950	5.64	3134	6.70	3306	7.80	<u>3629</u>	<u>10.12</u>	3954	12.77	4290	15.87	4608	19.13
5670	3000	2348	2.70	2453	3.18	2657	4.14	2855	5.15	3051	6.26	3233	7.40	3401	8.55	3713	10.95	<u>4008</u>	<u>13.53</u>	4319	16.54	4631	19.91
6048	3200	2491	3.21	2589	3.72	2782	4.74	2969	5.79	3154	6.94	3333	8.14	3499	9.36	3802	11.85	<u>4086</u>	<u>14.49</u>	<u>4363</u>	<u>17.35</u>	4658	20.67
6426	3400	2635	3.79	2727	4.32	2910	5.41	3087	6.50	3261	7.68	3434	8.93	3598	10.22	3896	12.83	4171	15.55	<u>4432</u>	<u>18.41</u>	<u>4698</u>	<u>21.57</u>
7182	3800	2924	5.14	3007	5.73	3171	6.94	3332	8.16	3490	9.40	3646	10.73	3801	12.13	4092	15.01	4355	17.92	4603	20.95	4840	24.10
7938	4200	3215	6.79	3290	7.44	3440	8.78	3587	10.13	3731	11.47	3873	12.85	4014	14.32	4292	17.42	4551	20.62	4789	23.85		

MAXIMUM RPM: Class I — 2904 Class II — 3787 Class III — 4991 Selections above 4000 RPM not recommended. Consult factory.

# BC DWDI 150

Outlet Area - 2.33 ft<sup>2</sup>

Wheel Dia. - 15.00 inches

Tip Speed - 3.93 x RPM

Max. BHP = 0.411 (RPM÷1000)<sup>3</sup>

CFM	OV	0.5" SP		1" SP		2" SP		3" SP		4" SP		5" SP		6" SP		8" SP		10" SP		12" SP		14" SP	
		RPM	BHP	RPM	BHP	RPM	BHP	RPM	BHP	RPM	BHP	RPM	BHP	RPM	BHP	RPM	BHP	RPM	BHP	RPM	BHP	RPM	BHP
1864	800	843	0.24	1116	0.49																		
2330	1000	926	0.32	<u>1153</u>	<u>0.59</u>																		
2796	1200	1019	0.43	1219	0.72	1589	1.46																
3262	1400	1121	0.57	1303	0.90	<u>1627</u>	<u>1.65</u>	1935	2.59														
3728	1600	1228	0.75	1395	1.12	1687	1.90	1968	2.85	2232	3.96												
4194	1800	1338	0.96	1493	1.36	1765	2.22	<u>2014</u>	<u>3.17</u>	2264	4.31	2497	5.55	<u>2711</u>	<u>6.83</u>								
4660	2000	1452	1.21	1595	1.65	1852	2.60	2081	3.58	<u>2306</u>	<u>4.70</u>	2529	5.99	2740	7.38								
5126	2200	1568	1.51	1702	1.99	1943	3.01	2160	4.07	<u>2363</u>	<u>5.19</u>	2569	6.47	2772	7.90	3147	10.96						
5592	2400	1686	1.86	1812	2.39	2039	3.48	2246	4.63	2437	5.79	2623	7.06	2812	8.48	3177	11.67	3511	15.05				
6058	2600	1805	2.27	1923	2.83	2139	4.01	2336	5.23	2519	6.48	2693	7.77	2864	9.16	3212	12.38	3539	15.94	3842	19.62		
6524	2800	1925	2.74	2037	3.34	2241	4.59	2430	5.90	2606	7.23	2772	8.59	2932	9.99	3254	13.18	3571	16.81	3870	20.71	4148	24.66
6990	3000	2047	3.29	2153	3.92	2347	5.24	2527	6.62	2696	8.04	2857	9.49	3009	10.94	3307	14.10	<u>3609</u>	<u>17.74</u>	3901	21.75	4177	25.95
7456	3200	2169	3.90	2269	4.56	2455	5.97	2627	7.42	2790	8.92	2945	10.46	3092	11.99	3374	15.19	<u>3655</u>	<u>18.80</u>	3936	22.82	4207	27.16
7922	3400	2292	4.58	2387	5.29	2565	6.77	2730	8.30	2886	9.87	3035	11.48	3179	13.12	3449	16.42	<u>3711</u>	<u>20.00</u>	<u>3979</u>	<u>24.03</u>	4241	28.40
8854	3800	2539	6.20	2626	6.99	2790	8.61	2942	10.30	3087	12.03	3226	13.79	3360	15.58	3616	19.25	3856	22.95	4090	26.89	<u>4328</u>	<u>31.25</u>
9786	4200	2789	8.19	2868	9.05	3020	10.83	3162	12.66	3297	14.55	3427	16.47	3553	18.42	3793	22.39	4022	26.45	4239	30.53	4451	34.83

MAXIMUM RPM: Class I — 2594 Class II — 3383 Class III — 4492 Selections above 4000 RPM not recommended. Consult factory.

Performance certified is for installation Type B & D: Free or ducted inlet, ducted outlet. Power rating (BHP) does not include transmission losses. Performance ratings do not include the effects of appurtenances (accessories).

**Legend:**

- Class I = Regular face to left of Class II
- Class III = *Italic face* to right of Class II
- Class II = Regular face in light shaded area
- Class IV = Italic face in darker shaded area
- Max. Static Efficiency = Underlined

# BC DWDI 165

Outlet Area - 2.82 ft<sup>2</sup>      Wheel Dia. - 16.50 inches      Tip Speed - 4.32 x RPM      Max. BHP = 0.662 (RPM ÷ 1000)<sup>3</sup>

CFM	OV	0.5" SP		1" SP		2" SP		3" SP		4" SP		5" SP		6" SP		8" SP		10" SP		12" SP		14" SP	
		RPM	BHP	RPM	BHP	RPM	BHP	RPM	BHP	RPM	BHP	RPM	BHP	RPM	BHP	RPM	BHP	RPM	BHP	RPM	BHP	RPM	BHP
2256	800	767	0.29	1015	0.60																		
2820	1000	842	0.39	<u>1048</u>	<u>0.71</u>																		
3384	1200	927	0.53	1108	0.88	1444	1.76																
3948	1400	1019	0.70	1185	1.10	<u>1479</u>	<u>1.99</u>	1759	3.13														
4512	1600	1116	0.90	1268	1.35	1534	2.30	1789	3.45	2029	4.79												
5076	1800	1217	1.16	1357	1.65	1605	2.69	<u>1831</u>	<u>3.84</u>	2058	5.21	2270	6.72	2465	8.27								
5640	2000	1320	1.46	1451	2.01	1684	3.15	1892	4.33	<u>2096</u>	<u>5.69</u>	2299	7.25	2491	8.93								
6204	2200	1426	1.83	1548	2.42	1767	3.65	1964	4.93	<u>2149</u>	<u>6.29</u>	<u>2336</u>	<u>7.84</u>	2520	9.56	2861	13.26						
6768	2400	1533	2.26	1647	2.89	1854	4.22	2042	5.60	2216	7.01	<u>2385</u>	<u>8.55</u>	2557	10.27	2888	14.11	3192	18.22				
7332	2600	1641	2.75	1749	3.43	1945	4.85	2124	6.33	2291	7.85	2448	9.40	<u>2604</u>	<u>11.09</u>	2920	14.99	3218	19.30	3493	23.75		
7896	2800	1751	3.33	1852	4.04	2038	5.56	2209	7.13	<u>2369</u>	<u>8.75</u>	2520	10.39	2666	12.10	<u>2958</u>	<u>15.94</u>	3247	20.36	3518	25.05	3771	29.85
8460	3000	1861	3.98	1957	4.74	2134	6.35	2298	8.02	2451	9.73	2597	11.48	2736	13.25	<u>3006</u>	<u>17.06</u>	3281	21.47	3546	26.31	3797	31.40
9024	3200	1972	4.72	2064	5.53	2232	7.22	<u>2389</u>	<u>8.99</u>	2536	10.79	2677	12.65	2811	14.51	3067	18.38	<i>3323</i>	<i>22.75</i>	<i>3579</i>	<i>27.64</i>	<i>3825</i>	<i>32.88</i>
9588	3400	2084	5.55	2171	6.41	2332	8.19	2482	10.05	2624	11.95	2760	13.90	2890	15.88	3136	19.88	<u>3374</u>	<u>24.21</u>	<u>3617</u>	<u>29.07</u>	<u>3856</u>	<u>34.38</u>
10716	3800	2309	7.51	<u>2388</u>	<u>8.46</u>	2537	10.43	2675	12.47	2807	14.56	2934	16.70	3055	18.86	3287	23.28	3506	27.78	<u>3718</u>	<u>32.54</u>	<u>3935</u>	<u>37.82</u>
11844	4200	2536	9.91	2608	10.95	2746	13.11	2875	15.33	2997	17.60	3116	19.93	3230	22.28	3449	27.11	3656	31.99	3854	36.96	4047	42.16

MAXIMUM RPM: Class I — 2358      Class II — 3075      Class III — 4083      Selections above 4000 RPM not recommended. Consult factory.

# BC DWDI 182

Outlet Area - 3.45 ft<sup>2</sup>      Wheel Dia. - 18.25 inches      Tip Speed - 4.78 x RPM      Max. BHP = 1.11 (RPM ÷ 1000)<sup>3</sup>

CFM	OV	0.5" SP		1" SP		2" SP		3" SP		4" SP		5" SP		6" SP		8" SP		10" SP		12" SP		14" SP	
		RPM	BHP	RPM	BHP	RPM	BHP	RPM	BHP	RPM	BHP	RPM	BHP	RPM	BHP	RPM	BHP	RPM	BHP	RPM	BHP	RPM	BHP
2760	800	692	0.33	<u>888</u>	<u>0.64</u>																		
3450	1000	755	0.45	938	0.81																		
4140	1200	824	0.61	1000	1.02	1270	1.91																
4830	1400	901	0.80	1063	1.27	1323	2.26	1541	3.34														
5520	1600	982	1.04	1131	1.56	1385	2.68	<u>1587</u>	<u>3.83</u>	1776	5.10												
6210	1800	1067	1.33	1204	1.90	1446	3.13	1647	4.41	1820	5.73	1988	7.17										
6900	2000	1157	1.69	1282	2.31	1510	3.64	1709	5.05	1877	6.47	2031	7.94	2183	9.55								
7590	2200	1249	2.12	1362	2.77	1578	4.21	1770	5.74	1939	7.29	2088	8.87	2227	10.49	2501	14.07						
8280	2400	1344	2.62	1447	3.32	1649	4.86	1833	6.48	2000	8.17	2150	9.89	2284	11.59	2539	15.24						
8970	2600	1439	3.21	1534	3.95	1723	5.58	1900	7.32	2062	9.11	2211	10.96	2346	12.81	2588	16.57	2822	20.68				
9660	2800	1536	3.88	1623	4.67	1801	6.40	1969	8.23	2126	10.14	2272	12.09	2408	14.10	2646	18.07	<u>2866</u>	<u>22.25</u>	<u>3082</u>	<u>26.75</u>		
10350	3000	1634	4.66	1715	5.49	1881	7.30	2041	9.24	2193	11.25	2335	13.32	2468	15.42	2708	19.70	2919	24.00	<u>3123</u>	<u>28.57</u>	3325	33.48
11040	3200	1733	5.54	1808	6.41	1964	8.32	2116	10.35	2262	12.46	2400	14.64	2530	16.85	2770	21.41	2979	25.93	<u>3174</u>	<u>30.62</u>	<u>3365</u>	<u>35.58</u>
11730	3400	1832	6.53	1903	7.45	2048	9.43	2194	11.57	2334	13.79	2467	16.05	2594	18.38	2837	23.18	3042	28.01	<u>3232</u>	<u>32.87</u>	<u>3413</u>	<u>37.88</u>
13110	3800	2032	8.87	2095	9.88	2224	12.03	2356	14.36	2484	16.77	2609	19.26	2729	21.79	2955	27.01	3164	32.36	<u>3356</u>	<u>37.79</u>	<u>3529</u>	<u>43.15</u>
14490	4200	2233	11.73	2290	12.83	2406	15.16	2524	17.64	2643	20.26	2759	22.96	2871	25.68	3087	31.33	3288	37.12	3478	43.07	3654	49.04

MAXIMUM RPM: Class I — 2149      Class II — 2776      Class III — 3504      Class IV — 3766

# BC DWDI 200

Outlet Area - 4.14 ft<sup>2</sup>      Wheel Dia. - 20.00 inches      Tip Speed - 5.24 x RPM      Max. BHP = 1.76 (RPM ÷ 1000)<sup>3</sup>

CFM	OV	0.5" SP		1" SP		2" SP		3" SP		4" SP		5" SP		6" SP		8" SP		10" SP		12" SP		14" SP	
		RPM	BHP	RPM	BHP	RPM	BHP	RPM	BHP	RPM	BHP	RPM	BHP	RPM	BHP	RPM	BHP	RPM	BHP	RPM	BHP	RPM	BHP
3312	800	632	0.40	810	0.76																		
4140	1000	689	0.55	856	0.97																		
4968	1200	752	0.73	912	1.22	1158	2.29																
5796	1400	821	0.96	970	1.52	1207	2.71	1406	4.01														
6624	1600	895	1.24	1032	1.87	1263	3.21	1448	4.59	1621	6.12												
7452	1800	973	1.60	1098	2.28	1319	3.75	1502	5.29	1660	6.87	1814	8.60										
8280	2000	1055	2.03	1169	2.77	1377	4.36	1559	6.06	1712	7.76	1853	9.53	1992	11.46								
9108	2200	1139	2.54	1243	3.33	1439	5.05	1614	6.87	1769	8.75	1904	10.63	<u>2032</u>	<u>12.59</u>	2282	16.88						
9936	2400	1225	3.14	1319	3.98	1504	5.83	1672	7.78	1825	9.81	1961	11.86	2083	13.90	2317	18.30						
10764	2600	1313	3.85	1399	4.74	1572	6.70	1733	8.78	1881	10.93	2017	13.15	2140	15.37	<u>2361</u>	<u>19.89</u>	<u>2575</u>	<u>24.82</u>				
11592	2800	1401	4.66	1480	5.59	1643	7.68	1796	9.87	1939	12.15	2073	14.52	2196	16.90	2414	21.69	<u>2614</u>	<u>26.68</u>	<u>2812</u>	<u>32.11</u>		
12420	3000	1490	5.59	1564	6.58	1716	8.77	1862	11.08	2000	13.49	2130	15.98	2252	18.52	2470	23.62	<u>2663</u>	<u>28.79</u>	<u>2849</u>	<u>34.28</u>	<u>3033</u>	<u>40.15</u>
13248	3200	1580	6.64	1649	7.69	1791	9.97	1930	12.41	2063	14.94	2189	17.55	2308	20.22	2527	25.68	<u>2718</u>	<u>31.13</u>	<u>2895</u>	<u>36.72</u>	<u>3070</u>	<u>42.70</u>
14076	3400	1670	7.82	1735	8.92	1868	11.31	2001	13.87	2129	16.54	2251	19.27	2366	22.05	2582	27.79	2775	33.61	2948	39.41	<u>3113</u>	<u>45.43</u>
15732	3800	1853	10.63	1910	11.83	<u>2028</u>	<u>14.42</u>	2148	17.20	2266	20.12	2379	23.07	2489	26.13	2695	32.38	2887	38.85	3061	45.32	<u>3220</u>	<u>51.80</u>
17388	4200	2036	14.06	2088	15.38	2194	18.17	2302	21.16	2411	24.31	2516	27.52	2619	30.81	2815	37.55	2999	44.51	3173	51.68	<u>3333</u>	<u>58.82</u>

MAXIMUM RPM: Class I — 1961      Class II — 2533      Class III — 3197      Class IV — 3442

Performance certified is for installation Type B & D: Free or ducted inlet, ducted outlet.  
 Power rating (BHP) does not include transmission losses.  
 Performance ratings do not include the effects of appurtenances (accessories).

**Legend:**

Class I = Regular face to left of Class II      Class III = *Italic face* to right of Class II  
 Class II = Regular face in light shaded area      Class IV = *Italic face* in darker shaded area  
 Max. Static Efficiency = Underlined

# BC DWDI 222

Outlet Area - 5.12 ft<sup>2</sup>

Wheel Dia. - 22.25 inches

Tip Speed - 5.83 x RPM

Max. BHP = 3.00 (RPM÷1000)<sup>3</sup>

CFM	OV	0.5" SP		1" SP		2" SP		3" SP		4" SP		5" SP		6" SP		8" SP		10" SP		12" SP		14" SP	
		RPM	BHP	RPM	BHP	RPM	BHP	RPM	BHP	RPM	BHP	RPM	BHP	RPM	BHP	RPM	BHP	RPM	BHP	RPM	BHP	RPM	BHP
4096	800	568	0.50	728	0.95																		
5120	1000	619	0.67	769	1.20																		
6144	1200	676	0.90	820	1.52	1041	2.83																
7168	1400	738	1.19	871	1.88	1085	3.36	1264	4.97														
8192	1600	804	1.54	927	2.31	1135	3.97	1301	5.68	1457	7.58												
9216	1800	875	1.98	987	2.82	1185	4.64	1350	6.54	1492	8.50	1630	10.64										
10240	2000	948	2.50	1050	3.42	1237	5.39	1401	7.49	1539	9.60	1665	11.78	1790	14.17								
11264	2200	1023	3.13	1116	4.11	1293	6.24	1451	8.51	1590	10.83	1711	13.14	1826	15.56	2051	20.88						
12288	2400	1101	3.89	1185	4.92	1351	7.20	1502	9.61	1640	12.13	1762	14.65	1872	17.19	2082	22.62						
13312	2600	1179	4.75	1256	5.84	1412	8.28	1557	10.85	1690	13.51	1813	16.27	1923	19.00	2122	24.60	2314	30.69				
14336	2800	1258	5.75	1330	6.92	1476	9.49	1614	12.21	1742	15.02	1863	17.95	1974	20.91	2169	26.81	2350	33.02	2527	39.69		
15360	3000	1338	6.89	1405	8.13	1542	10.84	1673	13.70	1797	16.67	1914	19.76	2024	22.91	2220	29.23	2393	35.60	2561	42.42	2726	49.66
16384	3200	1419	8.20	1481	9.49	1609	12.32	1734	15.34	1854	18.48	1967	21.70	2074	25.00	2271	31.76	2442	38.46	2602	45.42	2759	52.80
17408	3400	1500	9.66	1559	11.03	1678	13.97	1798	17.15	1913	20.44	2022	23.80	2126	27.25	2321	34.39	2494	41.57	2649	48.72	2798	56.20
19456	3800	1664	13.12	1716	14.62	1822	17.82	1930	21.26	2036	24.87	2138	28.54	2237	32.32	2422	40.04	2594	48.01	2751	56.05	2893	64.01
21504	4200	1829	17.37	1876	19.01	1971	22.45	2068	26.14	2166	30.04	2261	34.03	2353	38.08	2530	46.45	2695	55.04	2851	63.87	2996	72.79

MAXIMUM RPM: Class I — 1762 Class II — 2277 Class III — 2874 Class IV — 3088

# BC DWDI 245

Outlet Area - 6.21 ft<sup>2</sup>

Wheel Dia. - 24.50 inches

Tip Speed - 6.41 x RPM

Max. BHP = 4.85 (RPM÷1000)<sup>3</sup>

CFM	OV	0.5" SP		1" SP		2" SP		3" SP		4" SP		5" SP		6" SP		8" SP		10" SP		12" SP		14" SP	
		RPM	BHP	RPM	BHP	RPM	BHP	RPM	BHP	RPM	BHP	RPM	BHP	RPM	BHP	RPM	BHP	RPM	BHP	RPM	BHP	RPM	BHP
4968	800	516	0.60	661	1.15																		
6210	1000	562	0.82	699	1.46																		
7452	1200	614	1.09	745	1.84	946	3.44																
8694	1400	670	1.44	791	2.28	985	4.06	1148	6.03														
9936	1600	731	1.87	842	2.80	1031	4.81	1182	6.89	1323	9.18												
11178	1800	794	2.39	896	3.42	1077	5.64	1226	7.93	1355	10.30	1481	12.91										
12420	2000	861	3.04	954	4.15	1124	6.54	1272	9.08	1398	11.65	1513	14.31	1626	17.19								
13662	2200	930	3.81	1014	4.99	1175	7.58	1318	10.32	1444	13.13	1554	15.93	1659	18.90	1863	25.34						
14904	2400	1000	4.71	1077	5.98	1227	8.73	1365	11.67	1489	14.70	1601	17.80	1701	20.88	1891	27.44						
16146	2600	1071	5.76	1141	7.09	1283	10.05	1414	13.15	1535	16.39	1646	19.71	1747	23.06	1927	29.82	2102	37.24				
17388	2800	1143	6.98	1208	8.39	1341	11.52	1466	14.81	1583	18.24	1692	21.77	1793	25.37	1970	32.51	2134	40.03	2295	48.14		
18630	3000	1216	8.37	1276	9.86	1400	13.13	1520	16.63	1633	20.25	1738	23.95	1838	27.77	2016	35.43	2174	43.21	2326	51.45	2476	60.25
19872	3200	1289	9.94	1346	11.53	1461	14.93	1575	18.60	1684	22.41	1786	26.30	1884	30.34	2062	38.49	2218	46.66	2363	55.07	2506	64.06
21114	3400	1363	11.73	1416	13.38	1524	16.94	1633	20.80	1737	24.78	1837	28.89	1931	33.06	2108	41.71	2265	50.41	2406	59.10	2541	68.14
23598	3800	1512	15.94	1559	17.75	1655	21.62	1753	25.79	1849	30.15	1942	34.62	2032	39.21	2200	48.58	2356	58.23	2499	68.02	2628	77.68
26082	4200	1661	21.06	1704	23.06	1790	27.22	1878	31.69	1967	36.42	2053	41.24	2137	46.18	2298	56.35	2448	66.78	2590	77.52	2721	88.28

MAXIMUM RPM: Class I — 1601 Class II — 2068 Class III — 2610 Class IV — 2808

# BC DWDI 270

Outlet Area - 7.54 ft<sup>2</sup>

Wheel Dia. - 27.00 inches

Tip Speed - 7.07 x RPM

Max. BHP = 8.10 (RPM÷1000)<sup>3</sup>

CFM	OV	0.5" SP		1" SP		2" SP		3" SP		4" SP		5" SP		6" SP		8" SP		10" SP		12" SP		14" SP	
		RPM	BHP	RPM	BHP	RPM	BHP	RPM	BHP	RPM	BHP	RPM	BHP	RPM	BHP	RPM	BHP	RPM	BHP	RPM	BHP	RPM	BHP
6032	800	447	0.68	588	1.33																		
7540	1000	488	0.92	611	1.66																		
9048	1200	537	1.24	645	2.06	836	3.96																
10556	1400	590	1.64	687	2.56	861	4.63	1019	6.98														
12064	1600	646	2.14	735	3.17	895	5.44	1038	7.88	1175	10.64												
13572	1800	705	2.76	786	3.89	933	6.32	1069	9.03	1193	11.83	1315	14.96										
15080	2000	765	3.51	839	4.73	976	7.35	1103	10.23	1221	13.26	1332	16.42	1442	19.89								
16588	2200	828	4.41	895	5.71	1023	8.54	1142	11.58	1254	14.84	1360	18.21	1461	21.71								
18096	2400	891	5.47	953	6.86	1073	9.90	1185	13.11	1291	16.55	1392	20.14	1488	23.81	1672	31.65						
19604	2600	956	6.72	1013	8.19	1126	11.45	1231	14.83	1331	18.41	1428	22.23	1520	26.13	1694	34.20	1863	43.05				
21112	2800	1021	8.15	1074	9.71	1179	13.12	1279	16.73	1374	20.47	1466	24.44	1555	28.59	1723	37.12	1881	46.01	2037	55.75		
22620	3000	1087	9.80	1136	11.43	1235	15.04	1330	18.86	1420	22.77	1508	26.91	1593	31.22	1755	40.21	1907	49.46	2054	59.27	2199	69.82
24128	3200	1153	11.66	1199	13.38	1292	17.15	1383	21.21	1469	25.33	1552	29.58	1633	34.03	1790	43.49	1937	53.19	2077	63.17	2214	73.77
25636	3400	1219	13.74	1263	15.58	1350	19.49	1437	23.77	1519	28.08	1599	32.54	1677	37.18	1827	46.92	1970	57.13	2105	67.47	2236	78.23
28652	3800	1353	18.71	1392	20.71	1469	24.91	1548	29.56	1625	34.40	1698	39.23	1770	44.21	1908	54.51	2042	65.51	2171	76.92	2294	88.47
31668	4200	1487	24.75	1523	26.98	1593	31.54	1664	36.47	1734	41.65	1803	47.00	1870	52.41	1999	63.45	2123	74.97	2244	87.10	2362	99.71

MAXIMUM RPM: Class I — 1392 Class II — 1830 Class III — 2267 Class IV — 2544

Performance certified is for installation Type B & D: Free or ducted inlet, ducted outlet.  
Power rating (BHP) does not include transmission losses.  
Performance ratings do not include the effects of appurtenances (accessories).

### Legend:

Class I = Regular face to left of Class II Class III = *Italic face* to right of Class II  
Class II = Regular face in light shaded area Class IV = *Italic face* in darker shaded area  
Max. Static Efficiency = Underlined

# BC DWDI 300

Outlet Area - 9.31 ft<sup>2</sup>

Wheel Dia. - 30.00 inches

Tip Speed - 7.85 x RPM

Max. BHP = 13.72 (RPM÷1000)<sup>3</sup>

CFM	OV	0.5" SP		1" SP		2" SP		3" SP		4" SP		5" SP		6" SP		8" SP		10" SP		12" SP		14" SP	
		RPM	BHP	RPM	BHP	RPM	BHP	RPM	BHP	RPM	BHP	RPM	BHP	RPM	BHP	RPM	BHP	RPM	BHP	RPM	BHP	RPM	BHP
7448	800	403	0.84	529	1.64																		
9310	1000	439	1.13	550	2.05																		
11172	1200	483	1.53	581	2.55	<u>752</u>	<u>4.88</u>																
13034	1400	531	2.03	618	3.15	<u>775</u>	<u>5.72</u>	917	8.61														
14896	1600	581	2.64	661	3.91	805	6.70	<u>935</u>	<u>9.76</u>	1058	13.15												
16758	1800	634	3.40	707	4.80	840	7.81	962	11.14	<u>1074</u>	<u>14.62</u>	1183	18.45										
18620	2000	689	4.34	756	5.86	879	9.09	993	12.64	1099	16.38	<u>1199</u>	<u>20.28</u>	<u>1298</u>	<u>24.57</u>								
20482	2200	745	5.45	806	7.06	921	10.55	1028	14.31	1129	18.34	1224	22.49	<u>1315</u>	<u>26.80</u>	1493	36.36						
22344	2400	802	6.75	858	8.47	966	12.23	1066	16.17	1162	20.44	1253	24.88	<u>1339</u>	<u>29.39</u>	1505	39.09						
24206	2600	860	8.29	912	10.12	1013	14.12	1108	18.32	1198	22.74	<u>1285</u>	<u>27.44</u>	<u>1368</u>	<u>32.26</u>	<u>1525</u>	<u>42.25</u>	1677	53.19				
26068	2800	919	10.07	966	11.96	1062	16.24	1151	20.65	1237	25.30	1320	30.22	1400	35.33	1551	45.86	<u>1693</u>	<u>56.82</u>	1834	68.91		
27930	3000	978	12.09	1022	14.09	1111	18.54	1197	23.28	1279	28.17	1357	33.21	1434	38.57	1580	49.70	<u>1716</u>	<u>61.04</u>	<u>1848</u>	<u>73.11</u>	1979	86.19
29792	3200	1037	14.37	1079	16.51	1163	21.19	1245	26.21	1322	31.26	1397	36.53	1470	42.04	1611	53.69	1743	65.63	<u>1869</u>	<u>77.95</u>	<u>1993</u>	<u>91.13</u>
31654	3400	1097	16.96	1136	19.19	1215	24.06	1293	29.32	1368	34.74	1439	40.17	1509	45.87	1644	57.90	1773	70.53	<u>1895</u>	<u>83.36</u>	<u>2013</u>	<u>96.67</u>
35378	3800	1218	23.11	1253	25.58	1323	30.82	1393	36.48	1462	42.43	1529	48.50	1593	54.59	1718	67.39	1838	80.90	1954	94.99	<u>2065</u>	<u>109.29</u>
39102	4200	1339	30.61	1371	33.33	1434	38.96	1497	44.97	1561	51.45	1623	58.05	1683	64.70	1799	78.32	1911	92.60	2020	107.59	<u>2125</u>	<u>122.97</u>

MAXIMUM RPM: Class I — 1253 Class II — 1647 Class III — 2040 Class IV — 2290

# BC DWDI 330

Outlet Area - 11.27 ft<sup>2</sup>

Wheel Dia. - 33.00 inches

Tip Speed - 8.64 x RPM

Max. BHP = 22.10 (RPM÷1000)<sup>3</sup>

CFM	OV	0.5" SP		1" SP		2" SP		3" SP		4" SP		5" SP		6" SP		8" SP		10" SP		12" SP		14" SP	
		RPM	BHP	RPM	BHP	RPM	BHP	RPM	BHP	RPM	BHP	RPM	BHP	RPM	BHP	RPM	BHP	RPM	BHP	RPM	BHP	RPM	BHP
9016	800	366	1.01	481	1.99																		
11270	1000	399	1.37	500	2.48																		
13524	1200	439	1.85	528	3.09	<u>684</u>	<u>5.91</u>																
15778	1400	483	2.46	562	3.82	705	6.94	834	10.44														
18032	1600	529	3.21	601	4.73	732	8.11	<u>850</u>	<u>11.81</u>	962	15.93												
20286	1800	577	4.13	643	5.82	764	9.46	874	13.46	<u>976</u>	<u>17.67</u>	1076	22.37										
22540	2000	627	5.26	687	7.08	799	10.99	903	15.31	999	19.82	<u>1090</u>	<u>24.54</u>	<u>1180</u>	<u>29.73</u>								
24794	2200	678	6.61	733	8.56	838	12.80	935	17.34	1027	22.23	1113	27.23	<u>1195</u>	<u>32.40</u>	1357	43.98						
27048	2400	730	8.20	780	10.25	878	14.79	969	19.56	1056	24.70	1139	30.10	1218	35.63	<u>1368</u>	<u>47.29</u>						
29302	2600	782	10.03	829	12.24	921	17.09	1007	22.15	1089	27.51	1168	33.19	1244	39.08	1386	51.10	<u>1524</u>	<u>64.30</u>				
31556	2800	836	12.21	879	14.51	965	19.63	1047	25.03	1125	30.65	1200	36.56	1273	42.78	1410	55.50	<u>1539</u>	<u>68.75</u>	1667	83.36		
33810	3000	889	14.62	930	17.10	1011	22.50	1089	28.24	1163	34.11	1234	40.22	1303	46.61	1436	60.10	<u>1560</u>	<u>73.87</u>	<u>1680</u>	<u>88.48</u>	1799	104.30
36064	3200	944	17.46	981	19.99	1057	25.62	1132	31.73	1202	37.85	1270	44.21	1337	50.94	1465	65.04	1585	79.50	<u>1700</u>	<u>94.49</u>	<u>1812</u>	<u>110.33</u>
38318	3400	998	20.57	1034	23.31	1105	29.15	1176	35.53	1244	42.07	1309	48.70	1372	55.53	1495	70.12	1612	85.38	1723	100.93	<u>1830</u>	<u>117.00</u>
42826	3800	1107	27.95	1139	30.94	1203	37.31	1267	44.20	1330	51.44	1390	58.69	1449	66.16	1562	81.58	1671	97.91	1776	114.88	<u>1877</u>	<u>132.20</u>
47334	4200	1218	37.10	1246	40.29	1304	47.18	1362	54.55	1420	62.38	1476	70.32	1531	78.44	1636	94.87	1738	112.19	1837	130.34	<u>1933</u>	<u>149.08</u>

MAXIMUM RPM: Class I — 1139 Class II — 1497 Class III — 1855 Class IV — 2081

# BC DWDI 365

Outlet Area - 13.79 ft<sup>2</sup>

Wheel Dia. - 36.50 inches

Tip Speed - 9.65 x RPM

Max. BHP = 38.41 (RPM÷1000)<sup>3</sup>

CFM	OV	0.5" SP		1" SP		2" SP		3" SP		4" SP		5" SP		6" SP		8" SP		10" SP		12" SP		14" SP	
		RPM	BHP	RPM	BHP	RPM	BHP	RPM	BHP	RPM	BHP	RPM	BHP	RPM	BHP	RPM	BHP	RPM	BHP	RPM	BHP	RPM	BHP
11032	800	326	1.22																				
13790	1000	353	1.64	447	2.96																		
16548	1200	388	2.22	469	3.70	<u>616</u>	<u>7.02</u>																
19306	1400	426	2.93	498	4.60	630	8.25																
22064	1600	466	3.81	531	5.66	652	9.75	<u>762</u>	<u>14.00</u>														
24822	1800	508	4.89	567	6.93	677	11.32	780	16.08	876	20.92												
27580	2000	552	6.22	606	8.44	707	13.18	803	18.35	893	23.63	978	29.01										
30338	2200	597	7.80	646	10.17	740	15.29	829	20.78	915	26.65	995	32.38	<u>1072</u>	<u>38.30</u>								
33096	2400	643	9.69	688	12.20	775	17.67	858	23.47	939	29.72	1016	36.09	1089	42.34	1231	55.99						
35854	2600	690	11.90	731	14.53	813	20.42	890	26.50	966	33.06	1039	39.85	1110	46.82	<u>1243</u>	<u>60.57</u>	1374	76.30				
38612	2800	736	14.38	775	17.22	851	23.38	925	29.96	995	36.67	1065	43.90	1132	51.23	1260	65.98	<u>1382</u>	<u>81.34</u>				
41370	3000	784	17.31	820	20.28	891	26.74	961	33.70	1028	40.84	1093	48.22	1157	55.94	1281	71.94	<u>1397</u>	<u>87.68</u>	<u>1510</u>	<u>104.66</u>		
44128	3200	831	20.54	865	23.69	932	30.46	998	37.77	1062	45.30	1124	53.04	1185	61.10	<u>1304</u>	<u>78.00</u>	<u>1416</u>	<u>94.82</u>	<u>1523</u>	<u>111.76</u>	<u>1629</u>	<u>130.38</u>
46886	3400	879	24.23	911	27.55	974	34.60	1037	42.32	1098	50.24	1156	58.16	1214	66.50	1328	84.12	1437	102.21	1541	120.10	<u>1641</u>	<u>138.38</u>
52402	3800	976	33.01	1004	36.59	<u>1060</u>	<u>44.20</u>	1117	52.56	1173	61.31	1227	70.11	1280	79.11	1383	97.72	1485	117.61	1583	137.84	<u>1677</u>	<u>157.82</u>
57918	4200	1073	43.69	1098	47.57	1149	55.84	1200	64.67	1252	74.23	1302	83.86	1351	93.61	1446	113.51	1539	134.34	1631	156.25	<u>1721</u>	<u>178.78</u>

MAXIMUM RPM: Class I — 1015 Class II — 1302 Class III — 1651 Class IV — 1883

Performance certified is for installation Type B & D: Free or ducted inlet, ducted outlet. Power rating (BHP) does not include transmission losses. Performance ratings do not include the effects of appurtenances (accessories).

**Legend:**

Class I = Regular face to left of Class II     Class III = *Italic face* to right of Class II  
Class II = **Regular face in light shaded area**     Class IV = *Italic face in darker shaded area*  
Max. Static Efficiency = Underlined



# BC DWDI 402

Outlet Area - 16.77 ft<sup>2</sup>

Wheel Dia. - 40.25 inches

Tip Speed - 10.54 x RPM

Max. BHP = 62.63 (RPM÷1000)<sup>3</sup>

CFM	OV	0.5" SP		1" SP		2" SP		3" SP		4" SP		5" SP		6" SP		8" SP		10" SP		12" SP		14" SP	
		RPM	BHP	RPM	BHP	RPM	BHP	RPM	BHP	RPM	BHP	RPM	BHP	RPM	BHP	RPM	BHP	RPM	BHP	RPM	BHP	RPM	BHP
13416	800	296	1.49																				
16770	1000	321	2.01	405	3.59																		
20124	1200	352	2.70	426	4.53	558	8.50																
23478	1400	386	3.56	451	5.57	571	10.01																
26832	1600	423	4.64	481	6.86	591	11.84	691	17.02														
30186	1800	461	5.95	514	8.41	614	13.78	708	19.60	794	25.41												
33540	2000	501	7.58	549	10.23	641	16.01	728	22.30	810	28.75	887	35.29										
36894	2200	542	9.52	586	12.37	671	18.59	752	25.30	829	32.32	902	39.33	973	46.70								
40248	2400	583	11.77	624	14.84	703	21.50	778	28.53	851	36.08	921	43.84	987	51.41	1116	68.03						
43602	2600	625	14.43	663	17.68	737	24.81	807	32.22	876	40.21	942	48.43	1006	56.84	1127	73.62	1246	92.79				
46956	2800	668	17.53	703	20.95	772	28.46	838	36.32	903	44.69	966	53.42	1027	62.38	1143	80.32	1253	98.85				
50310	3000	711	21.05	743	24.60	808	32.51	871	40.92	932	49.62	991	58.61	1050	68.18	1162	87.56	1267	106.66	1370	127.46		
53664	3200	754	25.02	784	28.76	845	37.02	905	45.93	963	55.08	1019	64.45	1074	74.18	1182	94.74	1284	115.29	1381	135.87	1478	158.80
57018	3400	797	29.45	826	33.48	883	42.04	940	51.40	995	60.96	1049	70.86	1101	80.89	1204	102.23	1303	124.25	1397	145.92	1488	168.24
63726	3800	885	40.13	910	44.43	962	53.87	1013	63.93	1064	74.61	1113	85.33	1161	96.27	1254	118.79	1346	142.82	1435	167.44	1520	191.64
70434	4200	973	53.13	996	57.90	1042	67.91	1089	78.81	1135	90.18	1181	102.05	1225	113.80	1311	137.94	1396	163.49	1479	189.99	1560	217.13

**MAXIMUM RPM:** Class I — 920 Class II — 1181 Class III — 1497 Class IV — 1706

# BC DWDI 445

Outlet Area - 20.49 ft<sup>2</sup>

Wheel Dia. - 44.50 inches

Tip Speed - 11.65 x RPM

Max. BHP = 103.5 (RPM÷1000)<sup>3</sup>

CFM	OV	0.5" SP		1" SP		2" SP		3" SP		4" SP		5" SP		6" SP		8" SP		10" SP		12" SP		14" SP	
		RPM	BHP	RPM	BHP	RPM	BHP	RPM	BHP	RPM	BHP	RPM	BHP	RPM	BHP	RPM	BHP	RPM	BHP	RPM	BHP	RPM	BHP
16392	800	267	1.80																				
20490	1000	290	2.45	366	4.38																		
24588	1200	318	3.29	385	5.52	505	10.41																
28686	1400	349	4.34	408	6.81	517	12.28																
32784	1600	382	5.65	435	8.39	535	14.51	625	20.80														
36882	1800	417	7.28	465	10.29	556	16.89	640	23.92	718	31.03												
40980	2000	453	9.25	497	12.54	580	19.59	659	27.32	732	35.04	803	43.24										
45078	2200	490	11.62	530	15.12	607	22.73	680	30.89	750	39.53	816	48.09	880	57.05								
49176	2400	527	14.37	564	18.10	636	26.30	704	34.92	770	44.14	833	53.57	893	62.88	1010	83.27						
53274	2600	565	17.61	599	21.54	666	30.24	730	39.39	792	49.08	852	59.18	910	69.48	1019	89.87	1127	113.39				
57372	2800	604	21.41	635	25.51	698	34.75	758	44.40	816	54.47	873	65.13	929	76.26	1034	98.20	1133	120.69				
61470	3000	643	25.72	672	30.07	731	39.77	788	50.05	843	60.65	896	71.55	949	83.14	1051	107.00	1146	130.35	1239	155.70		
65568	3200	682	30.58	709	35.14	764	45.20	819	56.23	871	67.32	922	78.85	972	90.83	1069	115.74	1161	140.75	1249	166.00	1337	194.13
69666	3400	721	36.02	747	40.91	799	51.46	850	62.78	900	74.52	948	86.39	996	98.91	1089	124.94	1179	152.02	1263	178.08	1346	205.64
77862	3800	800	48.96	823	54.29	869	65.60	916	78.08	962	91.09	1006	104.08	1049	117.29	1134	145.09	1218	174.79	1298	204.66	1375	234.28
86058	4200	879	64.70	901	70.80	942	82.89	984	96.05	1026	110.04	1068	124.67	1108	139.10	1186	168.69	1262	199.51	1338	232.33	1411	265.35

**MAXIMUM RPM:** Class I — 832 Class II — 1068 Class III — 1354 Class IV — 1545

# BC DWDI 490

Outlet Area - 24.85 ft<sup>2</sup>

Wheel Dia. - 49.00 inches

Tip Speed - 12.83 x RPM

Max. BHP = 167.5 (RPM÷1000)<sup>3</sup>

CFM	OV	0.5" SP		1" SP		2" SP		3" SP		4" SP		5" SP		6" SP		8" SP		10" SP		12" SP		14" SP	
		RPM	BHP	RPM	BHP	RPM	BHP	RPM	BHP	RPM	BHP	RPM	BHP	RPM	BHP	RPM	BHP	RPM	BHP	RPM	BHP	RPM	BHP
19880	800	243	2.20																				
24850	1000	263	2.96	333	5.34																		
29820	1200	289	3.99	350	6.71	459	12.65																
34790	1400	317	5.27	371	8.29	469	14.84																
39760	1600	347	6.86	395	10.16	486	17.61	567	25.14														
44730	1800	379	8.85	423	12.54	505	20.49	581	28.97	652	37.62												
49700	2000	411	11.19	451	15.17	527	23.79	598	33.05	665	42.54	729	52.38										
54670	2200	445	14.09	481	18.30	551	27.52	617	37.36	681	47.90	741	58.31	799	69.14								
59640	2400	479	17.46	512	21.92	578	31.95	639	42.27	699	53.46	757	65.09	811	76.25	917	100.90						
64610	2600	514	21.46	544	26.12	605	36.69	663	47.77	719	59.45	774	71.83	826	84.12	926	109.19	1024	137.70				
69580	2800	549	26.02	577	30.98	634	42.15	689	53.98	741	66.03	793	79.02	844	92.57	939	119.07	1029	146.38				
74550	3000	584	31.19	610	36.40	664	48.25	716	60.78	765	73.38	814	86.85	862	100.87	954	129.56	1040	157.72	1125	188.71		
79520	3200	619	37.01	644	42.62	694	54.84	744	68.24	791	81.62	837	95.50	882	109.86	971	140.42	1055	170.98	1135	201.68	1214	235.29
84490	3400	655	43.72	678	49.51	725	62.23	772	76.13	818	90.58	861	104.77	905	120.12	989	151.50	1071	184.49	1147	215.94	1222	249.14
94430	3800	727	59.48	748	65.98	790	79.78	832	94.71	874	110.58	914	126.35	953	142.37	1030	176.00	1106	211.86	1179	248.30	1249	284.28
104370	4200	799	78.66	818	85.76	856	100.68	894	116.59	932	133.51	970	151.20	1006	168.53	1077	204.50	1147	242.48	1215	281.64	1282	322.21

**MAXIMUM RPM:** Class I — 748 Class II — 966 Class III — 1222 Class IV — 1401

Performance certified is for installation Type B & D: Free or ducted inlet, ducted outlet.  
 Power rating (BHP) does not include transmission losses.  
 Performance ratings do not include the effects of appurtenances (accessories).

**Legend:**

Class I = Regular face to left of Class II Class III = *Italic face* to right of Class II  
 Class II = Regular face in light shaded area Class IV = Italic face in darker shaded area  
 Max. Static Efficiency = Underlined

# BC DWDI 542

Outlet Area - 30.46 ft<sup>2</sup>      Wheel Dia. - 54.25 inches      Tip Speed - 14.20 x RPM      Max. BHP = 278.6 (RPM÷1000)<sup>3</sup>

CFM	OV	0.5" SP		1" SP		2" SP		3" SP		4" SP		5" SP		6" SP		8" SP		10" SP		12" SP		14" SP	
		RPM	BHP	RPM	BHP	RPM	BHP	RPM	BHP	RPM	BHP	RPM	BHP	RPM	BHP	RPM	BHP	RPM	BHP	RPM	BHP	RPM	BHP
24368	800	219	2.68																				
30460	1000	238	3.65	300	6.50																		
36552	1200	261	4.89	316	8.22	414	15.45																
42644	1400	286	6.44	335	10.15	424	18.24																
48736	1600	314	8.45	357	12.48	439	21.59	512	30.80														
54828	1800	342	10.81	382	15.36	456	25.10	525	35.55	589	46.13												
60920	2000	372	13.80	408	18.68	476	29.16	540	40.48	601	52.23	658	64.07										
67012	2200	402	17.28	435	22.51	498	33.80	558	45.97	615	58.69	669	71.38	722	84.86								
73104	2400	433	21.46	463	26.96	522	39.15	577	51.77	632	65.73	683	79.53	733	93.65	828	123.57						
79196	2600	464	26.26	492	32.14	547	45.11	599	58.60	650	73.06	699	88.01	747	103.50	836	133.65	925	168.84				
85288	2800	495	31.73	521	37.94	573	51.77	622	66.07	670	81.20	716	96.75	762	113.33	848	145.88	930	179.77				
91380	3000	527	38.13	551	44.63	600	59.22	646	74.26	691	89.95	735	106.36	779	123.85	862	158.98	940	193.73	1016	231.22		
97472	3200	559	45.34	582	52.33	627	67.28	672	83.64	714	99.86	756	117.06	797	134.84	877	172.11	953	209.65	1025	247.09	1096	288.00
103564	3400	591	53.24	613	60.88	655	76.33	698	93.61	738	110.65	778	128.59	817	147.01	894	186.15	967	225.89	1036	264.69	1104	305.60
115748	3800	656	72.70	675	80.06	713	97.56	751	115.87	789	135.33	825	154.57	861	174.64	931	216.21	999	259.71	1065	304.44	1128	348.34
127932	4200	722	96.55	739	105.19	773	123.33	808	143.19	842	163.77	876	185.25	909	206.82	973	250.84	1036	297.22	1098	345.77	1158	395.01

MAXIMUM RPM:      Class I — 676      Class II — 872      Class III — 1104      Class IV — 1260

# BC DWDI 600

Outlet Area - 37.26 ft<sup>2</sup>      Wheel Dia. - 60.00 inches      Tip Speed - 15.71 x RPM      Max. BHP = 461.0 (RPM÷1000)<sup>3</sup>

CFM	OV	0.5" SP		1" SP		2" SP		3" SP		4" SP		5" SP		6" SP		8" SP		10" SP		12" SP		14" SP	
		RPM	BHP	RPM	BHP	RPM	BHP	RPM	BHP	RPM	BHP	RPM	BHP	RPM	BHP	RPM	BHP	RPM	BHP	RPM	BHP	RPM	BHP
29808	800	198	3.28																				
37260	1000	215	4.45	272	8.01																		
44712	1200	236	5.99	285	9.97	374	18.84																
52164	1400	259	7.91	303	12.43	383	22.24																
59616	1600	283	10.24	323	15.30	397	26.42	463	37.69														
67068	1800	309	13.20	345	18.73	412	30.63	475	43.58	533	56.57												
74520	2000	336	16.83	369	22.87	430	35.58	489	49.74	543	63.75	595	78.40										
81972	2200	363	21.06	393	27.47	450	41.27	504	56.05	556	71.77	605	87.36	652	103.42								
89424	2400	391	26.15	418	32.83	472	47.90	522	63.43	571	80.22	618	97.50	662	114.17	749	151.36						
96876	2600	419	32.00	445	39.36	494	54.99	542	71.84	587	89.05	632	107.65	675	126.37	756	163.56	836	206.27				
104328	2800	448	38.92	471	46.39	518	63.29	562	80.64	605	98.93	648	118.69	689	138.64	767	178.64	841	220.00				
111780	3000	477	46.79	499	54.86	542	72.24	584	90.79	625	110.15	665	130.36	704	151.27	779	194.18	850	237.04	919	283.18		
119232	3200	506	55.65	526	63.93	567	82.33	607	102.01	646	122.39	684	143.47	721	165.20	793	210.56	861	255.85	927	302.47	991	352.33
126684	3400	535	65.58	554	74.36	592	93.26	631	114.44	668	135.79	704	157.66	739	180.04	808	227.43	874	276.00	937	324.07	998	373.59
141588	3800	593	88.86	611	99.00	645	119.52	679	141.71	713	165.26	746	189.12	778	213.23	841	263.74	903	317.41	963	372.47	1020	426.23
156492	4200	652	117.67	668	128.57	699	150.91	730	174.75	761	200.08	792	226.56	822	253.09	880	307.09	936	362.74	992	421.96	1047	483.16

MAXIMUM RPM:      Class I — 611      Class II — 789      Class III — 998      Class IV — 1146

# BC DWDI 660

Outlet Area - 45.08 ft<sup>2</sup>      Wheel Dia. - 66.00 inches      Tip Speed - 17.28 x RPM      Max. BHP = 743 (RPM÷1000)<sup>3</sup>

CFM	OV	0.5" SP		1" SP		2" SP		3" SP		4" SP		5" SP		6" SP		8" SP		10" SP		12" SP		14" SP	
		RPM	BHP	RPM	BHP	RPM	BHP	RPM	BHP	RPM	BHP	RPM	BHP	RPM	BHP	RPM	BHP	RPM	BHP	RPM	BHP	RPM	BHP
36064	800	180	3.97																				
45080	1000	195	5.34	247	9.66																		
54096	1200	214	7.19	260	12.20	340	22.80																
63112	1400	235	9.52	275	14.96	348	26.87																
72128	1600	258	12.49	294	18.58	360	31.73	421	45.63														
81144	1800	281	15.99	314	22.74	375	37.20	432	52.79	484	68.22												
90160	2000	305	20.27	335	27.56	391	43.08	444	59.97	494	77.31	541	94.90										
99176	2200	330	25.48	357	33.17	409	49.91	458	67.74	506	87.12	550	105.70	593	125.30								
108192	2400	356	31.78	380	39.73	429	57.92	475	76.97	519	97.01	562	118.08	602	138.26	681	183.21						
117208	2600	381	38.74	404	47.43	449	66.50	492	86.54	534	107.97	575	130.56	614	153.18	687	197.67	760	249.57				
126224	2800	407	47.00	428	56.05	471	76.63	511	97.63	550	119.71	589	143.55	626	167.46	697	215.88	764	265.61				
135240	3000	433	56.36	453	66.10	493	87.55	531	109.91	568	133.15	604	157.30	640	183.03	708	234.77	772	286.00	835	342.07		
144256	3200	460	67.34	478	77.27	515	99.36	552	123.56	587	147.88	621	172.91	655	199.47	721	254.87	783	309.88	842	365.02	901	426.42
153272	3400	486	79.17	504	90.17	539	113.36	573	138.01	607	164.08	640	190.77	672	218.02	734	274.56	795	334.52	852	392.35	907	451.61
171304	3800	539	107.47	555	119.49	586	144.35	618	172.08	649	200.73	678	228.65	708	258.80	765	319.69	821	384.18	875	449.97	927	515.25
189336	4200	593	142.57	607	155.36	636	183.07	664	211.79	692	242.29	720	274.14	747	305.91	800	371.57	851	439.04	902	510.87	952	584.93

MAXIMUM RPM:      Class I — 555      Class II — 717      Class III — 907      Class IV — 1040

Performance certified is for installation Type B & D: Free or ducted inlet, ducted outlet.  
Power rating (BHP) does not include transmission losses.  
Performance ratings do not include the effects of appurtenances (accessories).

**Legend:**

Class I = Regular face to left of Class II      Class III = *Italic face* to right of Class II  
Class II = Regular face in light shaded area      Class IV = *Italic face* in darker shaded area  
Max. Static Efficiency = Underlined

# BC DWDI 730

Outlet Area - 55.15 ft<sup>2</sup>

Wheel Dia. - 73.00 inches Tip Speed - 19.11 x RPM

Max. BHP = 1229 (RPM÷1000)<sup>3</sup>

CFM	OV	0.5" SP		1" SP		2" SP		3" SP		4" SP		5" SP		6" SP		8" SP		10" SP		12" SP		14" SP	
		RPM	BHP	RPM	BHP	RPM	BHP	RPM	BHP	RPM	BHP	RPM	BHP	RPM	BHP	RPM	BHP	RPM	BHP	RPM	BHP	RPM	BHP
44120	800	163	4.87																				
55150	1000	177	6.62	223	11.77																		
66180	1200	194	8.87	235	14.91	<u>308</u>	<u>28.06</u>																
77210	1400	213	11.73	249	18.39	315	32.99																
88240	1600	233	15.23	265	22.52	326	39.00	<u>381</u>	<u>55.98</u>														
99270	1800	254	19.55	284	27.85	339	45.50	390	64.30	<u>438</u>	<u>83.69</u>												
110300	2000	276	24.86	303	33.76	353	52.48	402	73.68	446	94.17	489	116.01										
121330	2200	299	31.38	323	40.66	370	61.16	414	82.82	457	106.24	497	129.10	<u>536</u>	<u>153.17</u>								
132360	2400	321	38.57	344	48.79	388	70.93	429	93.87	469	118.50	508	144.36	544	168.89	616	<u>224.47</u>						
143390	2600	345	47.62	365	57.90	406	81.38	445	106.00	483	132.25	519	158.94	555	187.27	<u>621</u>	<u>241.67</u>	687	305.15				
154420	2800	368	57.51	387	68.60	426	93.85	462	119.44	498	147.10	532	175.10	566	204.89	630	<u>263.90</u>	<u>691</u>	<u>325.31</u>				
165450	3000	392	69.23	410	81.12	446	107.31	480	134.39	514	163.34	546	192.35	579	224.34	640	<u>287.06</u>	<u>698</u>	<u>349.92</u>	755	<u>418.59</u>		
176480	3200	416	82.45	432	94.43	466	121.85	499	151.09	531	181.21	562	212.16	592	243.79	652	<u>311.99</u>	708	<u>379.24</u>	<u>762</u>	<u>447.86</u>	<u>815</u>	<u>522.43</u>
187510	3400	440	97.26	455	109.83	487	138.42	518	168.79	549	200.96	578	232.62	607	265.98	664	<u>336.48</u>	719	<u>409.64</u>	<u>770</u>	<u>479.43</u>	<u>820</u>	<u>552.44</u>
209570	3800	488	132.03	502	146.37	530	176.79	558	209.68	586	244.60	613	279.75	640	316.44	692	<u>391.70</u>	742	<u>469.48</u>	<u>791</u>	<u>550.28</u>	<u>838</u>	<u>630.10</u>
231630	4200	536	174.29	549	190.28	575	223.95	600	258.67	626	296.91	651	335.43	675	373.62	723	<u>454.03</u>	770	<u>538.37</u>	816	<u>626.11</u>	860	<u>713.82</u>

MAXIMUM RPM: Class I — 502      Class II — 648      Class III — 820      Class IV — 940

# BC DWDI 807

Outlet Area - 67.48 ft<sup>2</sup>

Wheel Dia. - 80.75 inches Tip Speed - 21.14 x RPM

Max. BHP = 2036 (RPM÷1000)<sup>3</sup>

CFM	OV	0.5" SP		1" SP		2" SP		3" SP		4" SP		5" SP		6" SP		8" SP		10" SP		12" SP		14" SP	
		RPM	BHP	RPM	BHP	RPM	BHP	RPM	BHP	RPM	BHP	RPM	BHP	RPM	BHP	RPM	BHP	RPM	BHP	RPM	BHP	RPM	BHP
53984	800	147	5.92																				
67480	1000	160	8.09	202	14.49																		
80976	1200	175	10.78	212	18.13	<u>278</u>	<u>34.17</u>																
94472	1400	192	14.23	225	22.47	285	40.46																
107968	1600	211	18.73	240	27.71	295	47.86	<u>344</u>	<u>68.24</u>														
121464	1800	230	24.03	256	33.79	306	55.41	353	78.96	<u>396</u>	<u>102.43</u>												
134960	2000	250	30.60	274	41.34	319	64.14	363	89.84	404	115.92	442	<u>141.88</u>										
148456	2200	270	38.26	292	49.75	334	74.51	375	101.94	413	129.87	450	158.71	<u>485</u>	<u>187.94</u>								
161952	2400	291	47.59	311	59.71	350	86.23	388	115.01	424	145.01	459	176.36	492	206.92	<u>556</u>	<u>273.35</u>						
175448	2600	312	58.33	330	70.87	367	99.55	402	129.42	436	161.11	470	195.48	502	229.50	<u>562</u>	<u>296.66</u>	621	373.26				
188944	2800	333	70.57	350	84.04	385	114.73	418	146.50	450	179.75	481	214.32	512	251.18	570	<u>323.70</u>	<u>625</u>	<u>398.65</u>				
202440	3000	354	84.44	370	98.74	403	131.11	434	164.52	464	199.00	494	235.94	523	273.83	579	<u>352.01</u>	<u>631</u>	<u>428.14</u>	683	<u>513.22</u>		
215936	3200	376	100.82	391	115.95	421	148.81	451	184.74	480	221.68	508	259.50	535	297.99	589	<u>380.93</u>	640	<u>463.92</u>	<u>688</u>	<u>545.93</u>	<u>737</u>	<u>639.81</u>
229432	3400	397	118.31	412	135.04	440	169.07	469	207.48	496	245.43	523	285.41	549	325.91	600	<u>411.15</u>	650	<u>501.24</u>	696	<u>586.37</u>	<u>742</u>	<u>677.87</u>
256424	3800	441	161.37	454	179.32	479	216.14	505	257.41	530	299.71	555	343.84	578	386.05	625	<u>477.94</u>	671	<u>575.00</u>	715	<u>673.08</u>	<u>758</u>	<u>772.28</u>
283416	4200	485	213.84	496	232.39	519	272.74	543	317.54	566	363.46	588	409.35	611	458.93	654	<u>556.54</u>	696	<u>658.47</u>	737	<u>763.98</u>	<u>778</u>	<u>875.23</u>

MAXIMUM RPM: Class I — 459      Class II — 589      Class III — 746      Class IV — 851

# BC DWDI 890

Outlet Area - 81.98 ft<sup>2</sup>

Wheel Dia. - 89.00 inches Tip Speed - 23.30 x RPM

Max. BHP = 3311 (RPM÷1000)<sup>3</sup>

CFM	OV	0.5" SP		1" SP		2" SP		3" SP		4" SP		5" SP		6" SP		8" SP		10" SP		12" SP		14" SP	
		RPM	BHP	RPM	BHP	RPM	BHP	RPM	BHP	RPM	BHP	RPM	BHP	RPM	BHP	RPM	BHP	RPM	BHP	RPM	BHP	RPM	BHP
65584	800	134	7.30																				
81980	1000	145	9.80	183	17.52																		
98376	1200	159	13.15	192	21.90	<u>252</u>	<u>41.40</u>																
114772	1400	175	17.52	204	27.24	258	48.82																
131168	1600	191	22.60	218	33.78	267	57.71	<u>312</u>	<u>82.81</u>														
147564	1800	208	28.91	233	41.43	278	67.58	320	95.67	<u>359</u>	<u>124.13</u>												
163960	2000	226	36.77	248	49.86	290	78.38	329	108.79	366	140.19	401	172.33										
180356	2200	245	46.49	265	60.48	303	90.48	340	123.57	375	158.12	408	192.40	<u>440</u>	<u>228.25</u>								
196752	2400	264	57.79	282	72.40	318	105.19	352	139.68	385	176.58	417	215.09	447	252.40	505	<u>333.15</u>						
213148	2600	283	70.79	300	86.60	333	120.95	365	157.56	396	196.33	426	236.75	455	277.95	<u>510</u>	<u>360.60</u>	564	454.82				
229544	2800	302	85.62	318	102.52	349	139.00	379	177.61	408	217.89	437	261.41	464	304.07	517	<u>392.86</u>	<u>567</u>	<u>484.13</u>				
245940	3000	321	102.39	336	120.27	365	158.43	394	200.21	421	241.76	448	286.21	475	333.66	525	<u>426.83</u>	<u>573</u>	<u>521.46</u>	619	<u>621.40</u>		
262336	3200	341	122.32	355	141.14	382	180.80	409	224.10	435	268.35	461	315.42	486	363.33	535	<u>464.31</u>	581	<u>564.54</u>	625	<u>665.69</u>	<u>668</u>	<u>774.89</u>
278732	3400	361	144.68	374	164.30	399	205.05	425	251.10	450	298.10	474	345.57	498	395.65	545	<u>501.17</u>	589	<u>606.61</u>	632	<u>714.10</u>	<u>673</u>	<u>822.69</u>
311524	3800	400	195.85	412	217.96	435	263.28	458	312.31	481	364.37	503	416.32	525	470.52	567	<u>580.40</u>	609	<u>699.20</u>	649	<u>818.72</u>	<u>688</u>	<u>939.27</u>
344316	4200	440	259.69	450</																			

"BC", "BAE", "BC" & "BAF" ARR. NO. 9 SWSI ROTATABLE CLASS I & II

**TWIN CITY FAN & BLOWER**  
MINNEAPOLIS, MINNESOTA 55442

DRAWN 8-13-82  
REVISED 7-15-05  
DWG. NO. AC-9239F

JOB: \_\_\_\_\_  
LOC. \_\_\_\_\_  
CONT. \_\_\_\_\_  
ENG./ARCH. \_\_\_\_\_  
S.O. NO. \_\_\_\_\_

SIZE CLASS DISCH. ROT. MTR. HP MTR. LOC. UNIT NO.  
CFM SP RPM BHP OV TS

ACCESSORIES REQ'D.

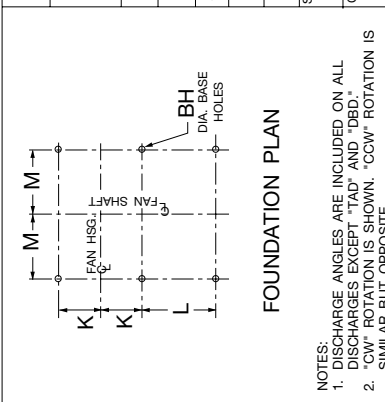

FOUNDATION PLAN

- NOTES:  
1. DISCHARGE ANGLES ARE INCLUDED ON ALL DISCHARGES EXCEPT "TAD" AND "DBD." "CW" ROTATION IS SHOWN. "CCW" ROTATION IS SIMILAR BUT OPPOSITE.  
\*3. SHAFT DIAMETER IS INCREASED TO 1.187 ON HI-TEMP. FANS WHICH REQUIRE SHAFT COOLERS.  
4. STANDARD ARR. 9 MOTOR LOCATION IS ON THE LEFT FOR "CW" ROTATION UNITS, AND ON THE RIGHT FOR "CCW" ROTATION. DIMENSION "FR" EQUALS MAX. MOTOR FRAME.

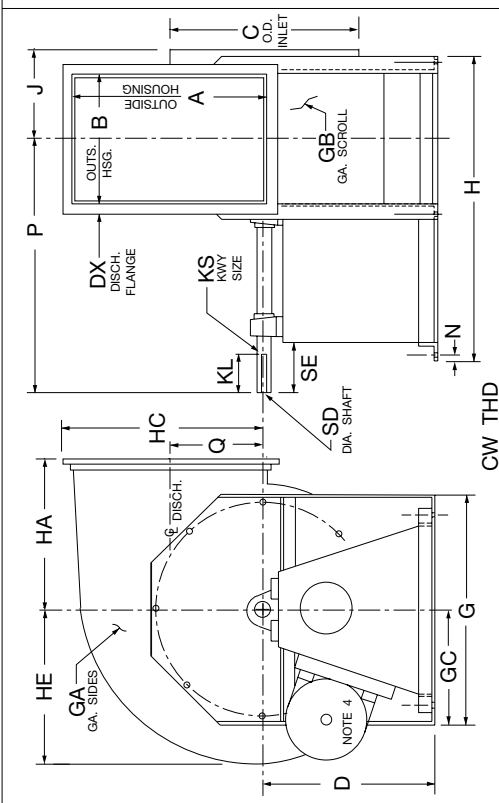

CW THD

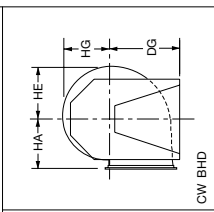

CW BHD

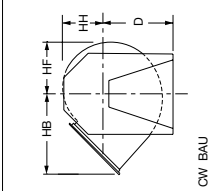

CW BAU

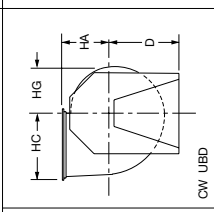

CW UBD

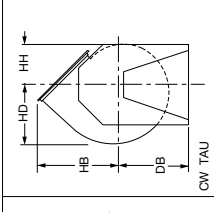

CW TAU

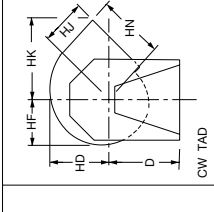

CW TAD

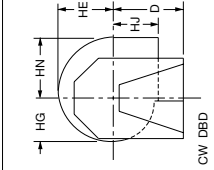

CW DBD

SIZE	A	B	BH	C	D	DX	FR	G	GA	GB	GC	H	HA	HB	HC	HD	HE	HF	SIZE
122	13.00	9.75	0.44	13.25	14.50	1.00	145T	16.00	14	14	8.00	27.00	9.75	16.75	13.94	11.19	10.56	9.94	122
135	14.31	10.81	0.44	14.56	15.75	1.00	184T	17.50	14	14	8.75	30.63	10.75	18.38	15.25	12.31	11.63	10.94	135
150	15.88	11.94	0.44	16.19	17.75	1.00	184T	19.00	14	14	9.50	31.75	11.94	20.31	16.81	13.75	12.88	12.13	150
165	17.44	13.19	0.44	17.75	19.00	1.00	215T	20.50	14	14	10.25	36.13	13.13	22.25	18.38	15.06	14.13	13.31	165
182	19.38	14.56	0.44	19.50	21.00	1.25	254T	22.50	12	14	11.25	41.88	14.50	24.81	20.56	16.69	15.69	14.75	182
200	21.19	15.94	0.56	21.38	22.75	1.25	254T	25.00	12	14	12.50	43.25	15.81	27.00	22.38	18.38	17.31	16.25	200
222	23.56	17.69	0.56	23.75	25.50	1.25	266T	27.25	12	14	13.63	45.25	17.69	30.00	24.75	20.44	19.06	17.94	222
245	25.94	19.44	0.56	26.06	28.00	1.25	266T	29.75	12	14	14.88	47.00	19.50	33.00	27.13	22.38	21.00	19.75	245
270	28.63	21.38	0.56	28.50	30.50	1.50	284T	33.00	12	14	16.50	51.75	21.44	36.44	30.06	24.69	23.19	21.81	270

SIZE	HG	HH	HJ	HK	HN	J	K	KL	KS CL I	KS CL II	L	M	N	P	Q	SD CL I	SD CL II	SE	SIZE
122	9.31	8.69	9.25	15.69	12.94	7.44	5.75	2.5	0.25x0.13	0.25x0.13	14.50	6.75	0.50	22.50	6.44	1.000	1.000*	3.25	122
135	10.25	9.56	10.25	17.31	14.25	8.00	6.31	2.5	0.25x0.13	0.25x0.13	17.00	7.38	0.50	25.56	7.13	1.000	1.000*	3.25	135
150	11.38	10.63	11.44	19.25	15.81	9.06	6.88	3.0	0.25x0.13	0.25x0.13	17.00	8.25	0.50	26.63	7.88	1.000	1.187	3.75	150
165	12.50	11.69	12.63	21.19	17.38	9.69	7.50	3.0	0.25x0.13	0.25x0.13	19.88	8.75	0.63	29.75	8.69	1.000*	1.188	3.75	165
182	13.81	12.88	14.00	23.56	19.31	10.88	8.19	3.5	0.38x0.19	0.38x0.19	24.25	9.63	0.63	35.31	9.63	1.187	1.437	4.25	182
200	15.91	14.13	15.31	25.75	21.13	11.56	8.88	4.0	0.38x0.19	0.38x0.19	24.25	10.63	0.63	36.00	10.56	1.437	1.437	4.25	200
222	16.81	15.69	17.19	28.75	23.50	12.44	10.00	4.5	0.38x0.19	0.38x0.19	23.50	11.75	0.88	37.13	11.75	1.437	1.437	4.75	222
245	18.50	17.25	19.00	31.75	25.88	13.31	10.88	4.5	0.38x0.19	0.38x0.19	23.50	12.88	0.88	38.50	12.94	1.437	1.687	5.25	245
270	20.44	19.06	20.94	35.00	28.56	14.25	11.81	4.5	0.38x0.19	0.38x0.19	26.38	14.13	0.88	42.31	14.25	1.687	1.687	5.25	270

DIMENSIONS ARE NOT TO BE USED FOR CONSTRUCTION. CERTIFIED DRAWINGS AVAILABLE UPON REQUEST.

"BCE", "BAE", "BC" & "BAF" ARR. NO. 1 & ARR. NO. 9 SWSI  
NON-ROTATABLE CLASS I & II

 **TWIN CITY FAN & BLOWER**  
MINNEAPOLIS, MINNESOTA 55442

**JOB:**

**LOC.**

**ENG./ARCH.**

**CERT. BY:**

**S.O. NO.**

DRAWN 8-14-82  
REVISED 7-15-05  
DWG. NO. AC-9238E

SIZE	CLASS	DISCH.	ROT.	MTR. LOC.	UNIT NO.
	CFM	SP	RPM	BHP	OV
ACCESSORIES REQ'D.					

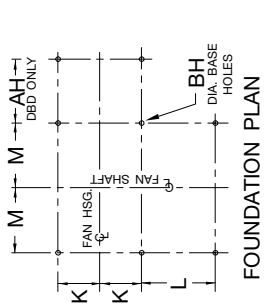

- NOTES:**
- DISCHARGE ANGLES ARE INCLUDED ON ALL DISCHARGES.
  - "CW" ROTATION IS SHOWN. "CCW" ROTATION IS SIMILAR BUT OPPOSITE.
  - STANDARD ARR. 9 MOTOR LOCATION IS ON THE LEFT FOR "CW" ROTATION UNITS, AND ON THE RIGHT FOR "CCW" ROTATION. DIMENSION "FR" EQUALS MAX. MOTOR FRAME.
  - FOR FANS WITH INLET BOX AT 90 DEGREES OR 270 DEGREES, USE "BAU" DISCHARGE DIMENSION "DF" FOR CENTERLINE HEIGHT.

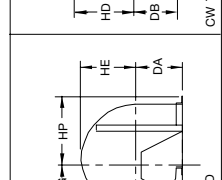
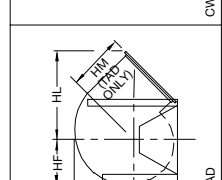
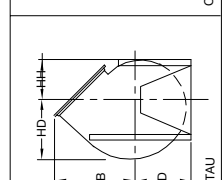
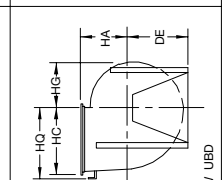
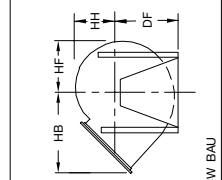
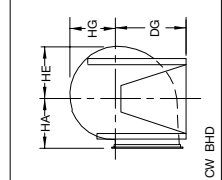
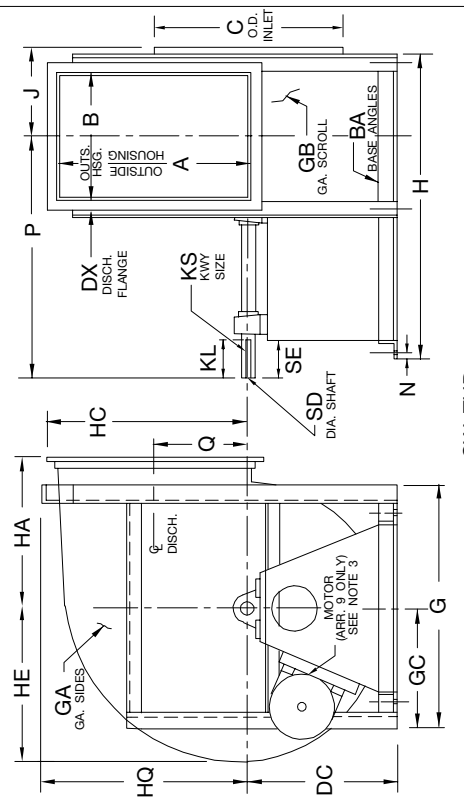

SIZE	A	AH	B	BA	BH	C	DA	DB	DC	DD	DE	DF	DG	DX	FR	GA	GB	GC	H	HA	HB	HC	SIZE
300	31.81	17.25	23.81	2.5x2.5	0.56	31.63	26.75	26.75	26.75	28.50	30.00	30.00	35.50	1.50	286T	10	12	20.50	55.75	23.81	40.31	33.25	300
330	35.13	19.06	26.06	2.5x2.5	0.56	34.75	30.00	30.00	30.00	31.00	32.75	39.00	39.00	1.50	324T	10	12	22.00	60.63	26.25	44.44	36.56	330
365	38.69	21.13	28.88	2.5x2.5	0.56	38.50	29.00	30.50	29.50	31.50	33.50	35.50	41.00	1.50	324T	10	12	24.00	63.38	29.00	48.88	40.13	365
402	42.63	23.31	31.81	3.0x3.0	0.81	42.44	32.00	32.50	33.00	35.25	37.00	39.50	45.50	1.50	326T	10	12	26.25	67.88	32.00	53.81	44.06	402
445	47.13	25.81	35.19	3.0x3.0	0.81	46.88	35.38	36.25	35.50	38.50	40.00	43.25	50.00	1.50	364T	10	12	28.25	72.88	35.38	59.38	48.56	445
490	51.94	28.13	38.63	3.0x3.0	0.81	51.63	39.00	38.75	39.00	42.25	44.00	47.50	54.75	2.00	364T	10	12	30.75	76.63	39.00	65.69	53.88	490
542	57.38	31.81	42.88	3.0x4.0	0.81	57.13	43.06	42.25	43.50	46.50	49.00	52.25	60.25	2.00	404T	10	12	33.50	87.50	43.06	72.38	59.31	542
600	63.50	34.94	47.31	3.0x4.0	0.81	63.13	47.69	45.00	48.00	51.25	54.00	57.50	66.25	2.00	404T	10	12	36.50	91.75	47.69	80.00	65.44	600
660	69.69	39.13	52.19	3.5x5.0	0.81	69.38	52.44	49.50	52.50	55.75	59.00	63.00	73.25	2.50	405T	10	12	40.00	101.25	52.44	88.06	72.13	660
730	77.25	42.63	57.56	3.5x5.0	0.81	76.75	58.00	54.25	57.00	61.75	64.50	69.50	80.75	2.50	405T	10	10	44.00	109.63	58.00	97.31	79.63	730
SIZE	HD	HE	HF	HG	HH	HL	HM	HP	HQ	J	K	KL	KS	KS	L	M	N	P	Q	SD	SD	SE	SIZE
300	27.44	25.75	24.25	22.75	21.25	47.13	33.44	34.25	34.25	15.50	13.31	5.0	0.50x0.25	0.50x0.25	26.88	15.88	1.13	44.56	15.81	1.937	1.937	5.75	300
330	30.13	28.38	26.69	25.00	23.31	51.00	35.56	37.56	37.56	16.63	14.44	5.0	0.50x0.25	0.50x0.25	29.50	17.38	1.13	48.31	17.50	1.937	2.187	5.75	330
365	33.50	31.50	29.63	27.75	25.88	55.50	38.38	41.13	41.13	18.00	15.81	5.0	0.50x0.25	0.63x0.31	29.50	18.88	1.13	49.69	19.25	1.937	2.437	5.75	365
402	37.00	34.69	32.63	30.56	28.50	60.50	41.56	45.56	45.56	20.00	17.56	5.0	0.50x0.25	0.63x0.31	30.00	20.88	1.38	51.69	21.25	2.187	2.437	5.75	402
445	40.88	38.25	36.00	33.75	31.50	65.69	44.38	50.06	50.06	21.69	19.25	5.5	0.63x0.31	0.63x0.31	31.63	22.88	1.38	55.50	23.50	2.437	2.687	6.25	445
490	44.88	42.19	39.69	37.19	34.69	72.31	48.44	54.88	54.88	23.38	20.94	5.5	0.63x0.31	0.75x0.38	32.00	25.38	1.38	57.56	25.88	2.687	2.937	6.25	490
542	49.75	46.69	43.94	41.19	38.44	78.88	52.31	61.31	59.75	26.50	23.56	6.0	0.75x0.38	0.88x0.44	36.63	27.63	1.88	64.81	28.63	2.937	3.437	6.75	542
600	55.00	51.89	48.63	45.56	42.50	86.25	56.56	67.44	65.75	28.75	25.81	7.0	0.75x0.38	0.88x0.44	36.38	30.63	1.88	66.81	31.69	2.937	3.437	6.75	600
660	60.38	56.81	53.38	49.94	46.50	94.81	62.00	74.63	72.25	32.19	28.75	7.0	0.88x0.44	1.0x0.50	39.00	33.13	2.38	72.88	34.75	3.437	3.937	7.75	660
730	66.94	62.88	59.13	55.38	51.63	104.19	67.69	82.13	79.75	34.94	31.44	7.5	0.88x0.44	1.0x0.50	42.00	37.13	2.38	79.06	38.50	3.437	3.937	8.25	730

DIMENSIONS ARE NOT TO BE USED FOR CONSTRUCTION. CERTIFIED DRAWINGS AVAILABLE UPON REQUEST.

"BCE", "BAE", "BC" & "BAF" ARR. NO. 1 SWSI NON-ROTATABLE CLASS I & II

TWIN CITY FAN & BLOWER MINNEAPOLIS, MINNESOTA 55442

3-11-87 DRAWN  
7-15-05 REVISED  
DWG. NO. AC-9259G

JOB: \_\_\_\_\_  
LOC: \_\_\_\_\_  
CONT: \_\_\_\_\_  
ENG./ARCH: \_\_\_\_\_  
S.O. NO. \_\_\_\_\_

SIZE DISCH ROT. UNIT NO.  
CFM SP RPM BHP OV TS

ACCESSORIES REQ'D.

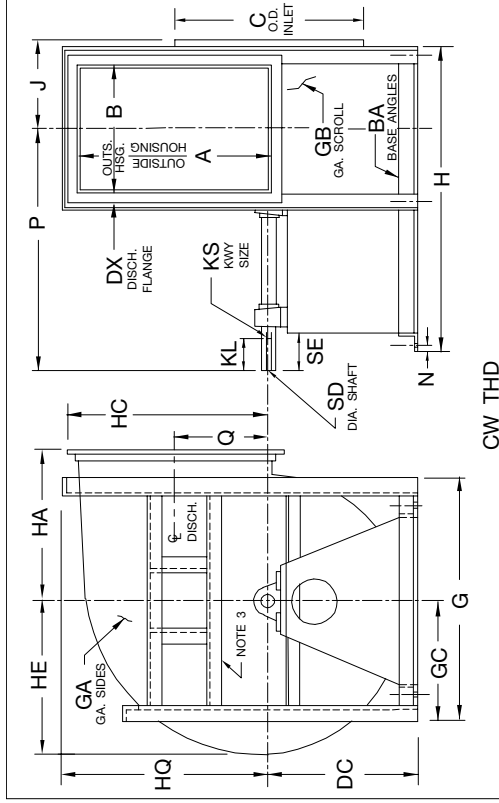
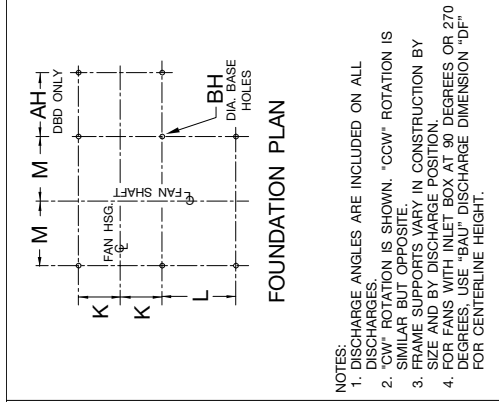

- NOTES:  
1. DISCHARGE ANGLES ARE INCLUDED ON ALL DISCHARGES.  
2. "CW" ROTATION IS SHOWN. "CCW" ROTATION IS SIMILAR BUT OPPOSITE.  
3. FRAME SUPPORTS VARY IN CONSTRUCTION BY SIZE AND BY DISCHARGE POSITION.  
4. FOR FANS WITH INLET BOX AT 90 DEGREES OR 270 DEGREES, USE "BAU" DISCHARGE DIMENSION "DF" FOR CENTERLINE HEIGHT.

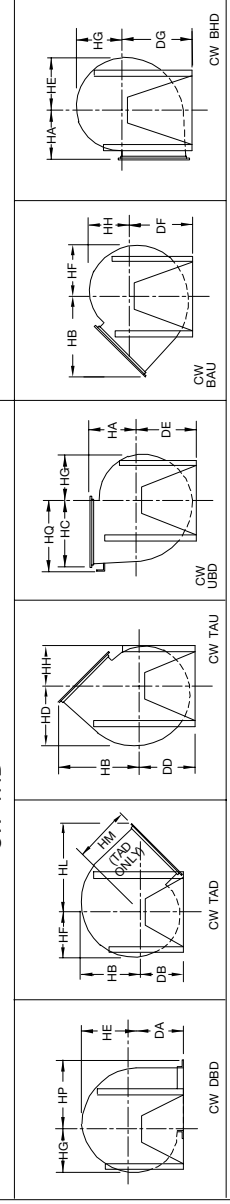

SIZE	AH	B	BA	BH	C	DA	DB	DC	DD	DE	DF	DG	DX	G	GA	GB	GC	H	HA	HB	HC	SIZE
807	85.44	63.63	3.5 x 5.0	0.81	84.88	64.19	59.50	63.00	67.50	72.00	76.50	89.00	2.50	95.50	10	10	47.75	118.63	64.19	107.50	87.81	807
890	94.13	70.13	3.5 x 5.0	0.81	93.38	70.00	65.50	69.25	73.75	78.25	85.00	97.75	2.50	106.50	7	10	53.25	128.13	70.00	117.75	96.50	890
982	104.00	77.50	4.0 x 6.0	0.81	103.50	77.75	71.50	76.50	80.00	86.50	92.00	108.25	2.50	122.00	7	7	61.00	140.63	77.75	130.13	106.31	982

SIZE	HD	HE	HF	HG	HH	HL	HM	HP	HQ	J	K	KL	KS	KS	L	M	N	P	Q	SD	SD	SE	SIZE
													CL I	CL II						CL I	CL II		
807	74.00	69.50	65.38	61.25	57.13	113.69	73.00	90.31	87.75	37.81	34.44	8.00	1.00x0.50	1.00x0.50	45.00	40.88	2.38	85.81	42.63	3.937	4.437	9.00	807
890	81.56	76.63	72.06	67.50	62.94	125.38	80.75	99.00	96.50	41.06	37.69	8.00	1.00x0.50	1.25x0.63	48.00	46.38	2.38	92.06	46.94	3.937	4.937	9.00	890
982	90.06	84.63	79.56	74.50	69.44	140.06	91.75	109.75	106.75	45.75	41.88	8.00	1.25x0.63	1.25x0.63	51.13	53.13	2.88	98.88	51.81	4.937	5.437	9.00	982

DIMENSIONS ARE NOT TO BE USED FOR CONSTRUCTION. CERTIFIED DRAWINGS AVAILABLE UPON REQUEST.

"BCE", "BAE", "BC" & "BAF" ARR. NO. 3 SWSI NON-ROTATABLE  
CLASS I & II

**TWIN CITY FAN & BLOWER**  
MINNEAPOLIS, MINNESOTA 55442

DRAWN 10-20-83  
REVISED 7-15-05  
DWG. NO. AC-9834G

JOB:  
LOC.  
ENG./ARCH.  
CERT. BY.  
S.O. NO.

SIZE CLASS DISCH. ROT. MTR. HP. MTR. LOC. UNIT NO.  
CFM SP RPM BHP OV TS  
ACCESSORIES REQ'D.

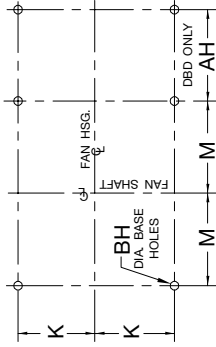

**FOUNDATION PLAN**

- NOTES:  
1. DISCHARGE ANGLES ARE INCLUDED ON ALL DISCHARGES.  
2. INLET BEARING BAR SUPPORT IS REMOVABLE. CW ROTATION IS SHOWN. "CCW" ROTATION IS SHOWN.  
3. INLET BEARING BAR SUPPORTS MAY EXTEND BEYOND BASE ANGLES. SEE DRAWING AC1000851 FOR DIMENSIONS IF SPACE LIMITATIONS ARE REQUIRED FOR MOUNTING FAN.  
4. BEARING BAR SUPPORTS MAY EXTEND BEYOND BASE ANGLES. SEE DRAWING AC1000851 FOR DIMENSIONS IF SPACE LIMITATIONS ARE REQUIRED FOR MOUNTING FAN.

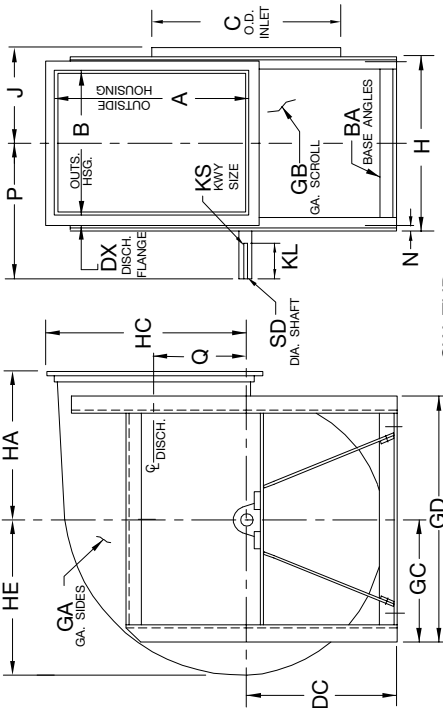

**CW THD**

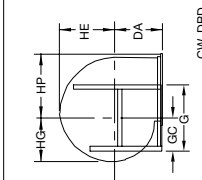
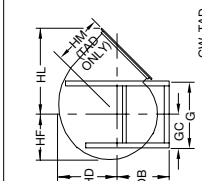
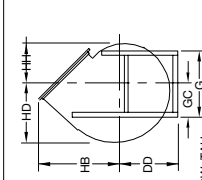
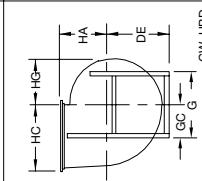
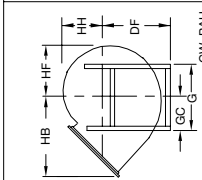
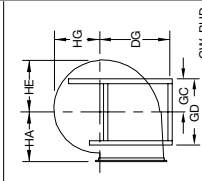

SIZE	A	AH	B	BA	BH	C	DA	DB	DC	DD	DE	DF	DG	DX	G	GA	GB	GC	GD	H	HA	HB	HC	SIZE
122	13.00	7.06	9.75	1.5 x 1.5	0.44	13.25	9.75	15.25	10.25	11.00	11.50	12.25	15.00	1.00	19.75	14	14	9.88	18.50	12.75	9.75	16.75	13.94	122
135	14.31	7.75	10.81	1.5 x 1.5	0.44	14.56	10.75	16.00	11.25	12.00	12.75	13.25	16.25	1.00	21.00	14	14	10.50	19.75	13.88	10.75	18.38	15.25	135
150	15.88	8.44	11.94	1.5 x 1.5	0.44	16.19	11.94	17.50	12.25	13.25	14.00	14.75	18.00	1.00	22.75	14	14	11.38	21.50	15.00	11.94	20.31	16.81	150
165	17.44	9.75	13.19	1.5 x 2.0	0.44	17.75	13.13	18.50	13.50	14.50	15.25	16.25	19.50	1.00	24.25	14	14	12.13	24.25	17.25	13.13	22.25	18.38	165
182	19.38	10.81	14.56	1.5 x 2.0	0.44	19.50	14.50	19.50	14.75	15.75	16.75	17.75	21.50	1.25	26.00	12	14	13.00	26.00	18.63	14.50	24.81	20.56	182
200	21.19	11.63	15.94	1.5 x 2.0	0.56	21.38	15.81	19.50	16.25	17.25	18.25	19.25	23.50	1.25	28.00	12	14	14.00	28.00	20.00	15.81	27.00	22.38	200
222	23.56	12.88	17.69	2.0 x 2.0	0.56	23.75	17.69	21.00	18.00	19.25	20.50	22.00	26.00	1.25	31.25	12	14	15.63	31.25	21.75	17.69	30.00	24.75	222
245	25.94	14.13	19.44	2.0 x 2.0	0.56	26.06	19.50	22.00	20.00	21.25	22.50	24.00	28.25	1.25	33.50	12	14	16.75	33.50	23.50	19.50	33.00	27.13	245
270	28.63	15.56	21.38	2.0 x 2.0	0.56	28.50	21.44	23.50	22.00	23.50	24.75	26.25	31.00	1.50	36.00	12	14	18.00	36.00	25.38	21.44	36.44	30.06	270

SIZE	HD	HE	HF	HG	HH	HL	HM	HP	J	K	KL	KS	CL I	CL II	M	N	P	Q	SD	CL I	SD	CL I	SD	SIZE
122	11.19	10.56	9.94	9.31	8.69	22.50	17.88	14.44	7.44	5.75	2.50	0.25 x 0.13	0.25 x 0.13	6.75	0.63	10.00	10.00	6.44	1.000	1.000	1.000	1.000	122	
135	12.31	11.63	10.94	10.25	9.56	24.06	18.75	15.75	8.00	6.31	3.00	0.25 x 0.13	0.25 x 0.13	7.38	0.63	10.56	10.56	7.13	1.000	1.000	1.000	1.000	135	
150	13.75	12.88	12.13	11.38	10.63	26.00	20.00	17.31	9.06	6.88	3.50	0.25 x 0.13	0.25 x 0.13	8.25	0.63	11.63	12.00	7.88	1.000	1.000	1.187	1.187	150	
165	15.06	14.13	13.31	12.50	11.69	27.88	21.06	19.38	9.69	7.75	3.00	0.25 x 0.13	0.25 x 0.13	8.75	0.88	12.25	12.63	8.69	1.000	1.000	1.187	1.187	165	
182	16.69	15.69	14.75	13.81	12.88	30.44	22.50	21.31	10.88	8.44	3.50	0.25 x 0.13	0.38 x 0.19	9.63	0.88	13.81	14.63	9.63	1.187	1.187	1.437	1.437	182	
200	18.38	17.31	16.25	15.19	14.13	32.75	23.94	23.13	11.56	9.13	3.50	0.38 x 0.19	0.38 x 0.19	10.63	0.88	15.31	15.31	10.56	1.437	1.437	1.437	1.437	200	
222	20.44	19.06	17.94	16.81	15.69	36.06	26.25	25.50	12.44	10.00	4.00	0.38 x 0.19	0.38 x 0.19	11.75	0.88	16.69	16.69	11.75	1.437	1.437	1.437	1.437	222	
245	22.38	21.00	19.75	18.50	17.25	38.88	27.81	27.88	13.31	10.88	4.50	0.38 x 0.19	0.38 x 0.19	12.88	0.88	18.06	18.44	12.94	1.437	1.437	1.687	1.687	245	
270	24.69	23.19	21.81	20.44	19.06	42.38	29.88	30.56	14.25	11.81	4.50	0.38 x 0.19	0.38 x 0.19	14.13	0.88	19.00	19.38	14.25	1.437	1.437	1.687	1.687	270	

DIMENSIONS ARE NOT TO BE USED FOR CONSTRUCTION. CERTIFIED DRAWINGS AVAILABLE UPON REQUEST.





"BCE", "BAE", "BC" & "BAF" ARR. NO. 1 SWSI NON-ROTATABLE  
CLASS III

**TWIN CITY FAN & BLOWER**  
MINNEAPOLIS, MINNESOTA 55442

DRAWN 8-16-82  
REVISED 7-15-05  
DWG. NO. AC-9244D

JOB:

LOC.

ENG./ARCH.

CERT. BY.

S.O. NO.

SIZE CLASS DISCH. ROT. MTR. HP MTR. LOC. UNIT NO.

CFM SP RPM BHP OV TS

ACCESSORIES REQD.

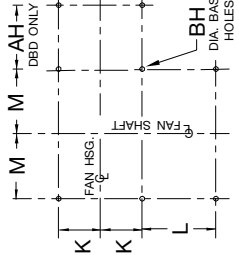

FOUNDATION PLAN

- NOTES:  
1. DISCHARGE ANGLES ARE INCLUDED ON ALL DRAWINGS.  
2. "CW" ROTATION IS SHOWN. "CCW" ROTATION IS SIMILAR BUT OPPOSITE.  
3. FOR FANS SIZE 182-300 (EXCEPT TAD, 182-200) WITH INLET BOX AT 90 DEGREES OR 270 DEGREES, USE "BAU" DISCHARGE DIMENSION "DF" FOR CENTERLINE HEIGHT.

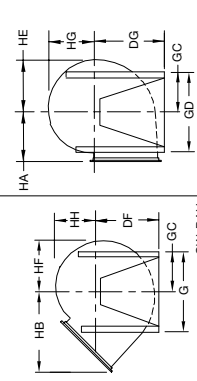
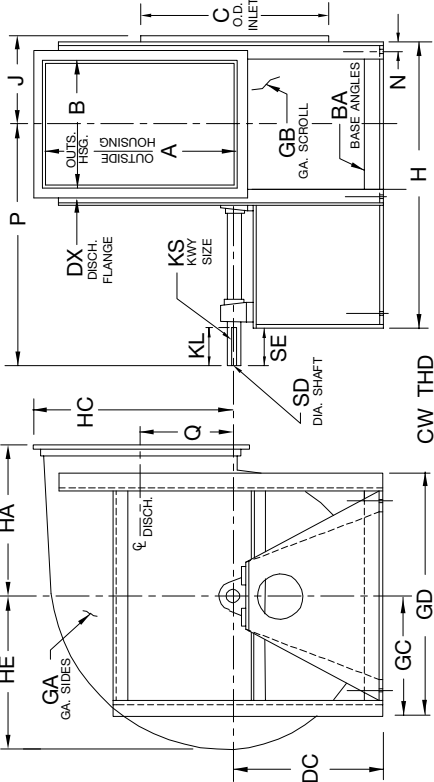

SIZE	A	HA	HE	HC	HD	BH	BA	BC	DA	DB	DC	DD	DE	DF	DG	DX	G	GA	GB	GC	GD	H	HA	SIZE
122	13.13	7.63	9.88	1.5 x 2.0	0.44	13.25	9.75	15.25	11.00	11.50	12.25	15.50	1.25	19.75	10	9.88	18.63	22.38	9.75	122				
135	14.44	8.31	10.94	1.5 x 2.0	0.44	14.56	10.75	16.00	11.25	12.00	12.75	13.25	16.75	21.00	10	10.50	19.88	24.00	10.75	135				
150	16.00	9.00	12.06	1.5 x 2.0	0.44	16.19	11.94	16.75	12.25	13.25	14.00	14.75	18.50	22.75	10	11.38	21.63	26.63	11.94	150				
165	17.56	9.81	13.31	1.5 x 2.0	0.44	17.75	13.13	17.50	13.50	14.50	15.25	16.25	19.50	24.25	10	12.13	23.13	27.88	13.13	165				
182	19.50	10.88	14.63	2.0 x 2.0	0.56	19.50	14.50	18.50	14.75	15.75	16.75	17.25	22.00	27.00	10	13.50	27.00	30.13	14.50	182				
200	21.31	11.69	16.00	2.0 x 2.0	0.56	21.38	15.81	19.50	16.25	17.25	18.25	19.25	24.00	29.00	10	14.50	29.00	32.50	15.81	200				
222	23.69	13.44	17.75	2.5 x 2.5	0.56	23.75	17.69	21.00	18.00	19.25	20.50	22.00	26.50	32.25	10	16.13	32.25	37.25	17.69	222				
245	26.19	14.63	19.63	2.5 x 2.5	0.56	26.06	19.50	22.00	20.00	21.25	22.50	24.00	28.75	34.50	7	17.25	34.50	40.63	19.50	245				
270	28.88	16.19	21.56	2.5 x 2.5	0.56	28.50	21.44	23.50	22.00	23.50	24.75	26.25	31.50	37.00	7	18.50	37.00	44.63	21.44	270				
300	32.00	17.81	23.94	3.0 x 3.0	0.81	31.63	23.81	26.00	24.50	26.00	27.50	29.50	34.75	42.00	7	21.00	42.00	49.50	23.81	300				
330	35.31	19.63	26.19	3.0 x 3.0	0.81	34.75	26.25	27.75	27.00	28.50	30.00	32.25	37.75	45.00	7	22.50	45.00	53.75	26.25	330				

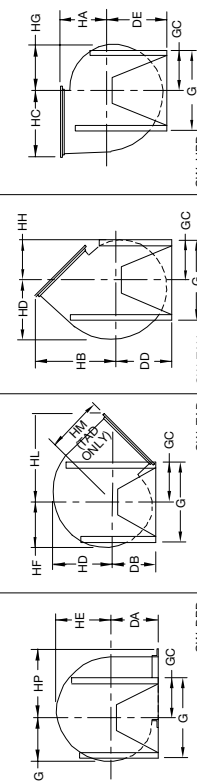

SIZE	A	HA	HE	HC	HD	BH	BA	BC	DA	DB	DC	DD	DE	DF	DG	DX	G	GA	GB	GC	GD	H	HA	SIZE
122	17.00	14.25	11.25	10.63	10.00	9.38	8.75	22.94	18.19	15.00	7.94	6.06	3.00	0.38 x 0.19	7.50	6.50	0.88	18.94	6.44	1.437	3.50	122		
135	18.63	15.56	12.38	11.69	11.00	10.31	9.63	24.50	19.06	16.31	8.50	6.63	3.00	0.38 x 0.19	8.00	7.13	0.88	20.00	7.13	1.437	3.50	135		
150	20.56	17.13	13.81	12.94	12.19	11.44	10.69	26.50	20.31	17.88	9.06	7.19	3.50	0.38 x 0.19	9.50	8.00	0.88	22.56	7.88	1.687	4.00	150		
165	22.50	18.69	15.13	14.19	13.38	12.56	11.75	28.31	21.38	19.44	9.69	7.81	3.50	0.38 x 0.19	9.50	8.75	0.88	23.19	8.69	1.687	4.00	165		
182	24.81	20.63	16.75	15.75	14.81	13.88	12.94	31.06	23.31	21.38	10.31	8.44	4.50	0.38 x 0.19	10.50	9.63	0.88	25.81	9.63	1.687	5.00	182		
200	27.06	22.44	18.38	17.38	16.31	15.25	14.19	33.31	24.89	23.19	11.00	9.13	4.50	0.50 x 0.25	11.50	10.63	0.88	27.50	10.56	1.937	5.00	200		
222	30.06	24.81	20.50	19.13	18.00	16.88	15.75	36.69	27.06	26.06	12.38	10.25	5.00	0.50 x 0.25	13.75	11.50	1.13	31.38	11.75	1.937	5.50	222		
245	33.25	27.50	22.50	21.13	19.88	18.63	17.38	38.88	27.50	28.50	13.31	11.19	6.00	0.50 x 0.25	15.25	12.63	1.13	34.81	12.94	2.187	6.50	245		
270	36.50	30.19	24.81	23.31	21.94	20.56	19.19	42.06	29.25	31.19	14.31	12.19	6.00	0.50 x 0.25	17.25	13.88	1.13	37.81	14.25	2.187	6.50	270		
300	40.38	33.31	27.50	25.81	24.31	22.81	21.13	46.75	32.81	34.81	16.00	13.63	7.00	0.63 x 0.31	19.00	15.63	1.38	42.25	15.81	2.437	7.75	300		
330	44.44	36.63	30.19	28.44	26.75	25.06	23.38	50.63	34.94	38.13	17.13	14.75	7.00	0.63 x 0.31	21.00	17.13	1.38	45.38	17.50	2.687	7.75	330		

DIMENSIONS ARE NOT TO BE USED FOR CONSTRUCTION. CERTIFIED DRAWINGS AVAILABLE UPON REQUEST.

"BCE", "BAE", "BC" & "BAF" ARR. NO. 1 SWSI NON-ROTATABLE CLASS III

**TWIN CITY FAN & BLOWER**  
MINNEAPOLIS, MINNESOTA 55442

DRAWN 8-16-82  
REVISED 7-15-05  
DWG. NO. AC-9245E

JOB: \_\_\_\_\_

LOC. \_\_\_\_\_

ENG./ARCH. \_\_\_\_\_

CERT. BY. \_\_\_\_\_

S.O. NO. \_\_\_\_\_

SIZE	CLASS	DISCH.	ROT.	MTR. HP	MTR. LOC.	UNIT NO.
CFM	SP	RPM	BHP	OV	TS	

ACCESSORIES REQ'D.

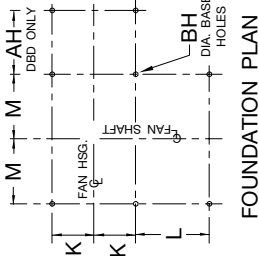

FOUNDATION PLAN

- NOTES:  
1. DISCHARGE ANGLES ARE INCLUDED ON ALL DISCHARGES.  
2. "CW" ROTATION IS SHOWN. "CCW" ROTATION IS SIMILAR BUT OPPOSITE.  
3. FOR FANS WITH INLET BOX AT 90 DEGREES OR 270 DEGREES, USE "BAU" DISCHARGE DIMENSION "DF" FOR CENTERLINE HEIGHT.

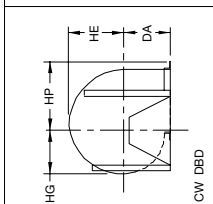
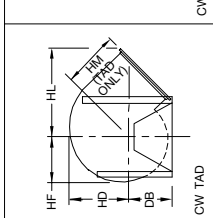
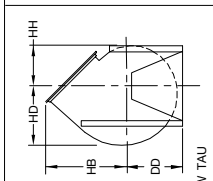
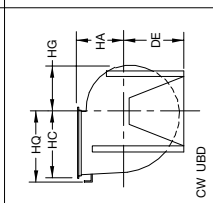
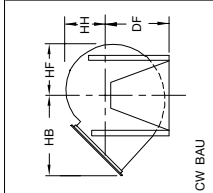
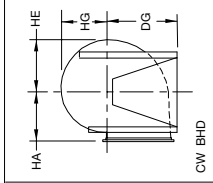
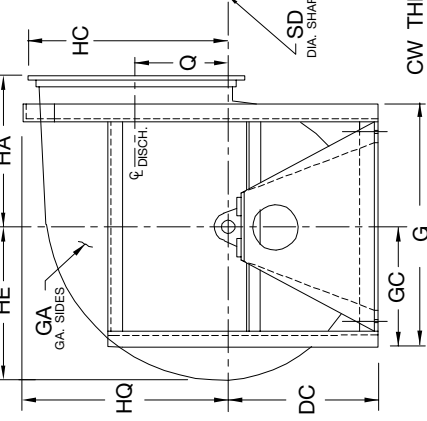
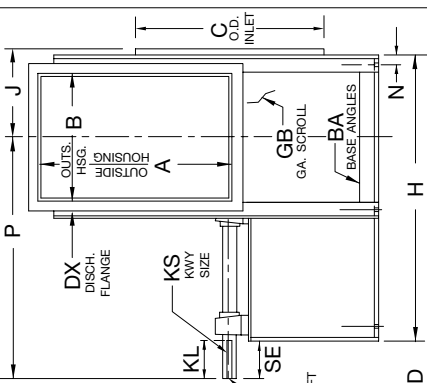

SIZE	A	AH	B	BA	BH	C	DA	DB	DC	DD	DE	DF	DG	DX	G	GA	GB	GC	H	HA	HB	SIZE
365	38.88	21.69	29.00	3.0 x 3.0	0.81	38.50	29.00	29.25	29.50	31.50	33.50	35.50	41.50	1.5 x 1.5	49.00	7	7	24.50	58.00	29.00	48.94	365
402	42.81	24.38	31.94	3.0 x 4.0	0.81	42.44	32.00	31.75	33.00	35.25	37.00	39.50	45.50	2.0 x 2.0	52.50	7	7	26.25	64.00	32.00	54.19	402
445	47.31	26.88	35.31	3.0 x 4.0	0.81	46.88	35.38	36.25	35.50	38.50	40.00	43.25	50.00	2.0 x 2.0	56.50	7	7	28.25	70.38	35.38	59.75	445
490	52.13	29.19	38.75	3.0 x 4.0	0.81	51.63	39.00	38.75	39.00	42.25	44.00	47.50	54.75	2.0 x 2.0	61.50	7	7	30.75	75.75	39.00	65.69	490
542	57.56	32.88	43.00	3.5 x 5.0	0.81	57.13	43.06	42.25	43.50	46.50	49.00	52.25	60.75	2.5 x 2.5	67.00	7	7	33.50	82.00	43.06	72.81	542
600	63.69	36.00	47.44	3.5 x 5.0	0.81	63.13	47.69	45.00	48.00	51.25	54.00	57.50	66.75	2.5 x 2.5	74.00	7	7	37.00	89.50	47.69	80.38	600
660	69.88	40.19	52.31	4.0 x 6.0	0.81	69.38	52.44	49.50	52.50	55.75	59.00	63.00	73.75	2.5 x 2.5	80.00	7	7	40.00	98.38	52.44	88.13	660
730	77.38	43.69	57.69	4.0 x 6.0	0.81	76.75	58.00	54.25	57.00	61.75	64.50	69.50	81.25	2.5 x 2.5	88.00	7	7	44.00	106.75	58.00	97.38	730
807	85.56	48.13	63.75	4.0 x 6.0	0.81	84.88	64.19	59.50	63.00	67.50	72.00	76.50	89.50	2.5 x 2.5	96.50	7	7	48.25	115.75	64.19	107.50	807
890	94.25	51.31	70.13	4.0 x 6.0	0.81	93.38	70.00	65.50	69.25	73.75	78.25	85.00	98.25	2.5 x 2.5	107.50	7	7	53.75	125.13	70.00	117.75	890
SIZE	HC	HD	HE	HF	HG	HH	HL	HM	HP	HQ	J	K	KL	KS	L	M	N	P	Q	SD	SE	SIZE
365	40.19	33.63	31.56	29.69	27.81	25.94	55.13	37.75	41.69		18.50	16.13	7.00	0.63 x 0.31	22.50	18.63	1.38	48.25	19.25	2.687	7.75	365
402	44.63	37.06	34.75	32.69	30.63	28.56	60.38	40.75	46.63		21.00	18.13	8.00	0.75 x 0.38	24.00	20.38	1.88	52.75	21.25	2.937	8.75	402
445	49.13	41.00	38.31	36.06	33.81	31.56	66.56	44.94	51.13		22.69	19.81	8.00	0.88 x 0.44	27.00	22.38	1.88	57.69	23.50	3.437	9.00	445
490	53.94	44.94	42.25	39.75	37.25	34.75	72.44	48.50	55.94		24.38	21.50	9.00	0.88 x 0.44	29.00	24.88	1.88	62.38	25.88	3.437	10.00	490
542	59.88	49.88	46.75	44.00	41.25	38.50	79.75	52.88	62.38		27.50	24.13	9.00	1.00 x 0.50	29.50	27.13	2.38	65.50	28.63	3.937	10.00	542
600	66.00	55.06	51.75	48.69	45.63	42.56	87.56	57.81	68.50		29.75	26.38	9.50	1.00 x 0.50	32.50	30.13	2.38	71.25	31.69	4.437	10.50	600
660	72.19	60.50	56.88	53.44	50.00	46.56	94.94	62.06	75.69		33.19	29.31	10.00	1.00 x 0.50	35.00	32.63	2.88	77.19	34.75	4.437	11.00	660
730	79.69	67.00	62.94	59.19	55.44	51.69	104.25	67.75	83.19		35.88	32.00	10.50	1.25 x 0.63	38.00	36.63	2.88	83.38	38.50	4.937	11.50	730
807	87.88	74.13	69.56	65.44	61.31	57.19	114.31	73.75	91.38		38.88	35.00	10.50	1.25 x 0.63	41.00	40.63	2.88	89.38	42.63	4.937	11.50	807
890	96.56	81.63	76.69	72.13	67.56	63.00	125.94	81.50	100.06		42.06	38.19	11.00	1.25 x 0.63	44.00	45.88	2.88	96.06	46.94	5.437	12.00	890

DIMENSIONS ARE NOT TO BE USED FOR CONSTRUCTION. CERTIFIED DRAWINGS AVAILABLE UPON REQUEST.

"BC", "BAE", "BC" & "BAF" ARR. NO. 9 SWSI NON-ROTATABLE CLASS III

TWIN CITY FAN & BLOWER  
MINNEAPOLIS, MINNESOTA 55442

DRAWN 10-29-90  
REVISED 7-15-05  
DWG. NO. AC-9128E

JOB:

LOC.

CONT.

ENG./ARCH.

S.O. NO.

SIZE	CLASS	DISCH.	ROT.	MTR. HP	MTR. LOC.	UNIT NO.
CFM	SP	RPM	BHP	CV	TS	

ACCESSORIES REQ'D.

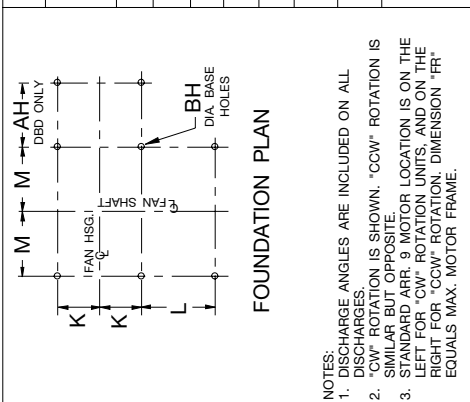

FOUNDATION PLAN

- NOTES:  
1. DISCHARGE ANGLES ARE INCLUDED ON ALL DISCHARGES.  
2. "CW" ROTATION IS SHOWN. "CCW" ROTATION IS SIMILAR BUT OPPOSITE.  
3. STANDARD ARR. 9 MOTOR LOCATION IS ON THE LEFT FOR "CW" ROTATION UNITS, AND ON THE RIGHT FOR "CCW" ROTATION. DIMENSION "FR" EQUALS MAX. MOTOR FRAME.

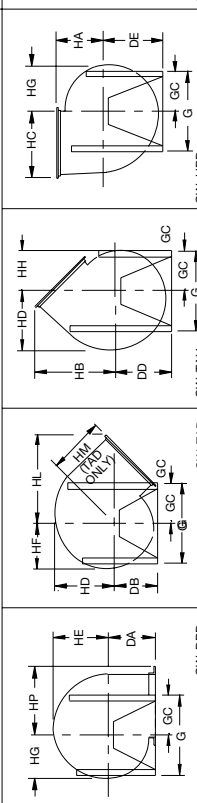
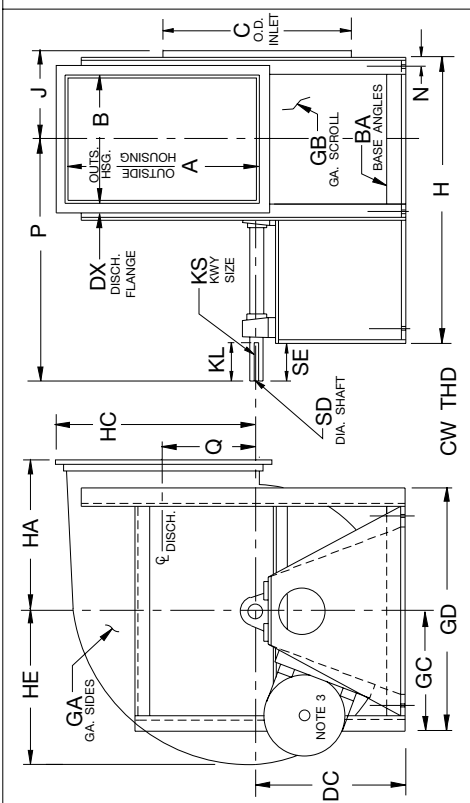

SIZE	AH	B	BA	BAH	C	DA	DB	DC	DD	DE	DF	DG	DX	FR	G	GA	GB	GC	GD	H	HA	SIZE
122	13.13	7.63	9.88	1.5 x 2.0	0.44	13.25	20.75	20.75	20.75	20.75	20.75	20.75	1.25	215T	19.75	10	9.88	18.63	32.25	9.75	122	
135	14.44	8.31	10.94	1.5 x 2.0	0.44	14.56	23.50	23.50	23.50	23.50	23.50	23.50	1.25	256T	21.00	10	10.50	19.88	38.75	10.75	135	
150	16.00	9.00	12.06	1.5 x 2.0	0.44	16.19	23.75	23.75	23.75	23.75	23.75	23.75	1.25	256T	22.75	10	11.38	21.63	39.88	11.94	150	
165	17.56	9.81	13.31	1.5 x 2.0	0.44	17.75	23.75	23.75	23.75	23.75	23.75	23.75	1.25	256T	24.25	10	12.13	23.13	41.13	13.14	165	
182	19.50	10.88	14.63	2.0 x 2.0	0.56	19.50	26.25	26.25	26.25	26.25	26.25	26.25	1.25	286T	27.00	10	13.50	27.00	44.63	14.50	182	
200	21.31	11.69	16.00	2.0 x 2.0	0.56	21.38	29.50	29.50	29.50	29.50	29.50	29.50	1.25	326T	29.00	10	14.50	29.00	47.50	15.81	200	
222	23.69	13.44	17.75	2.5 x 2.5	0.56	23.75	30.00	30.00	30.00	30.00	30.00	30.00	1.25	326T	32.25	10	16.13	32.25	50.25	17.69	222	
245	26.19	14.63	19.63	2.5 x 2.5	0.56	26.06	30.25	30.25	30.25	30.25	30.25	30.25	1.50	326T	34.50	7	17.25	34.50	52.13	19.50	245	
270	28.88	16.19	21.56	2.5 x 2.5	0.56	28.50	33.00	33.00	33.00	33.00	33.00	33.00	1.50	365T	37.00	7	18.50	37.00	55.25	21.44	270	
300	32.00	17.81	23.94	3.0 x 3.0	0.81	31.63	33.50	33.50	33.50	33.50	33.50	34.75	1.50	365T	42.00	7	21.00	42.00	58.63	23.81	300	
330	35.31	19.63	26.19	3.0 x 3.0	0.81	34.75	34.00	34.00	34.00	34.00	34.00	37.75	1.50	365T	45.00	7	22.50	45.00	60.88	26.25	330	

SIZE	HB	HC	HD	HE	HF	HG	HH	HL	HM	HP	J	K	KL	KS	L	M	N	P	Q	SD	SE	SIZE
122	17.00	14.25	11.25	10.63	10.00	9.38	8.75	22.94	18.19	15.00	7.94	6.06	3.50	0.38 x 0.19	17.38	6.50	0.88	29.31	6.44	1.4375	4.00	122
135	18.63	15.56	12.38	11.69	11.00	10.31	9.63	24.50	19.06	16.31	8.50	6.63	4.25	0.38 x 0.19	22.75	7.13	0.88	36.00	7.13	1.4375	4.75	135
150	20.56	17.13	13.81	12.94	12.19	11.44	10.69	26.50	20.31	17.88	9.06	7.19	4.25	0.38 x 0.19	22.75	8.00	0.88	36.56	7.88	1.6875	4.75	150
165	22.50	18.69	15.13	14.19	13.38	12.56	11.75	28.31	21.38	19.44	9.69	7.81	4.25	0.38 x 0.19	22.75	8.75	0.88	37.19	8.69	1.6875	4.75	165
182	24.81	20.63	16.75	15.75	14.81	13.88	12.94	31.06	23.31	21.38	10.31	8.44	5.00	0.38 x 0.19	25.00	9.63	0.88	40.81	9.63	1.6875	5.50	182
200	27.06	22.44	18.38	17.38	16.31	15.25	14.19	33.31	24.69	23.19	11.00	9.13	6.00	0.50 x 0.25	26.50	10.63	0.88	44.25	10.56	1.9375	6.75	200
222	30.06	24.81	20.50	18.00	16.88	15.75	14.50	36.69	27.06	26.06	12.38	10.25	6.00	0.50 x 0.25	26.75	11.50	1.13	45.63	11.75	1.9375	6.75	222
245	33.25	27.50	22.50	21.13	19.88	18.63	17.38	38.88	27.50	28.50	13.31	11.19	6.00	0.50 x 0.25	26.75	12.63	1.13	46.56	12.94	2.1875	6.75	245
270	36.50	30.19	24.81	23.31	21.94	20.56	19.19	42.06	29.25	31.19	14.31	12.19	7.00	0.50 x 0.25	27.88	13.88	1.13	49.69	14.25	2.1875	7.75	270
300	40.38	33.31	27.50	25.81	24.31	22.81	21.13	46.75	32.81	34.81	16.00	13.63	6.75	0.63 x 0.31	28.13	15.63	1.38	51.38	15.81	2.4375	7.75	300
330	44.44	36.63	30.19	28.44	26.75	25.06	23.38	50.63	34.94	38.13	17.13	14.75	6.75	0.63 x 0.31	28.13	17.13	1.38	52.50	17.50	2.6875	7.75	330

DIMENSIONS ARE NOT TO BE USED FOR CONSTRUCTION. CERTIFIED DRAWINGS AVAILABLE UPON REQUEST.

"BCE", "BAE", "BC" & "BAF" ARR. NO. 9 SWSI NON-ROTATABLE CLASS III

TWIN CITY FAN & BLOWER  
MINNEAPOLIS, MINNESOTA 55442

DRAWN 10-30-90  
REVISED 7-15-05  
DWG. NO. AC-9129D

JOB:  
LOC.  
CONT.  
ENG./ARCH.

S.O. NO.  
SIZE CLASS DISCH. ROT. MTR. HP MTR. LOC. UNIT NO.  
CFM SP RPM BHP OV TS  
ACCESSORIES REQ'D.

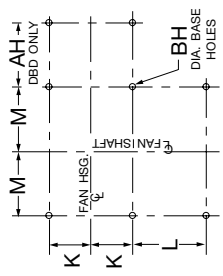

FOUNDATION PLAN

- NOTES:  
1. DISCHARGE ANGLES ARE INCLUDED ON ALL DISCHARGES.  
2. "CW" ROTATION IS SHOWN. "CCW" ROTATION IS SIMILAR BUT OPPOSITE.  
3. STANDARD ARR. 9 MOTOR LOCATION IS ON THE LEFT FOR CW ROTATION UNITS, AND ON THE RIGHT FOR CCW ROTATION. DIMENSION "FR" EQUALS MAX. MOTOR FRAME.

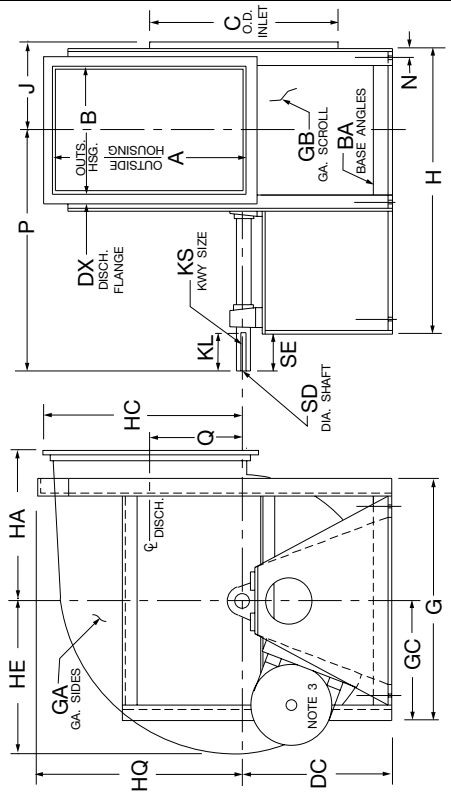

CW THD

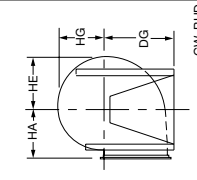

CW BHD

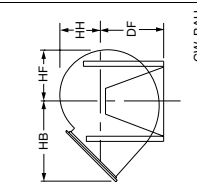

CW BAU

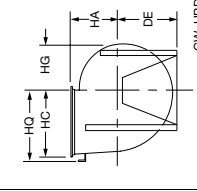

CW UBD

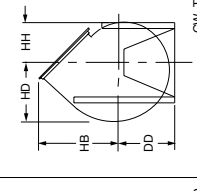

CW TAU

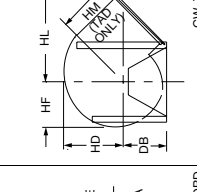

CW TAD

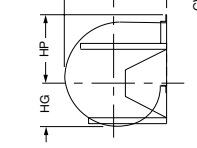

CW DBD

SIZE	A	AH	HE	HF	HG	HH	HL	HM	HP	HQ	J	K	KL	KS	L	M	N	P	Q	SD	SE	SIZE
365	38.88	21.69	29.00	3.0 x 3.0	0.81	38.50	37.50	37.50	37.50	37.50	16.13	8.00	0.63 x 0.31	34.88	18.63	1.38	61.88	19.25	2.687	9.00	365	
402	42.81	24.38	31.94	3.0 x 4.0	0.81	42.44	40.25	40.25	40.25	40.25	18.13	8.75	0.75 x 0.38	41.13	20.38	1.88	71.13	21.25	2.937	10.00	402	
445	47.31	26.88	35.31	3.0 x 4.0	0.81	46.88	41.00	41.00	41.00	41.00	19.81	8.75	0.88 x 0.44	41.13	22.38	1.88	72.81	23.50	3.437	10.00	445	
490	52.13	29.19	38.75	3.0 x 4.0	0.81	51.63	41.00	42.25	44.00	47.50	21.50	8.75	0.88 x 0.44	41.13	24.88	1.88	74.50	25.88	3.437	10.00	490	
542	57.56	32.88	43.00	3.5 x 5.0	0.81	57.13	43.06	42.25	43.50	49.00	24.13	9.00	1.00 x 0.50	41.25	27.13	2.38	77.75	28.63	3.937	10.50	542	
600	63.69	36.00	47.44	3.5 x 5.0	0.81	63.13	47.69	45.00	48.00	51.25	26.38	9.00	1.00 x 0.50	41.25	30.13	2.38	80.00	31.69	4.437	10.50	600	
660	69.88	40.19	52.31	4.0 x 6.0	0.81	69.38	52.44	49.50	52.50	55.75	29.31	9.00	1.00 x 0.50	41.75	32.63	2.88	83.44	34.75	4.437	10.50	660	
730	77.38	43.69	57.69	4.0 x 6.0	0.81	76.75	58.00	54.25	57.00	61.75	31.88	9.00	1.25 x 0.63	41.75	36.63	2.88	86.13	38.50	4.937	10.50	730	
807	85.56	48.13	63.75	4.0 x 6.0	0.81	84.88	64.19	59.50	63.00	67.50	35.00	9.00	1.25 x 0.63	41.75	40.38	2.88	89.13	42.63	4.937	10.50	807	
890	94.25	51.31	70.13	4.0 x 6.0	0.81	93.38	70.00	65.50	69.25	73.75	38.19	9.00	1.25 x 0.63	41.75	45.88	2.88	92.31	46.94	5.437	10.50	890	

DIMENSIONS ARE NOT TO BE USED FOR CONSTRUCTION. CERTIFIED DRAWINGS AVAILABLE UPON REQUEST.



"BCE", "BAE", "BC" & "BAF" ARR. NO. 1 SWSI NON-ROTATABLE CLASS IV

**TWIN CITY FAN & BLOWER**  
MINNEAPOLIS, MINNESOTA 55442

JOB: \_\_\_\_\_  
LOC. \_\_\_\_\_  
ENG./ARCH. \_\_\_\_\_  
CERT. BY. \_\_\_\_\_  
S.O. NO. \_\_\_\_\_

SIZE \_\_\_\_\_ CLASS \_\_\_\_\_ DISCH. \_\_\_\_\_ ROT. \_\_\_\_\_ MTR. HP \_\_\_\_\_ MTR. LOC. \_\_\_\_\_ UNIT NO. \_\_\_\_\_  
CFM \_\_\_\_\_ SP \_\_\_\_\_ RPM \_\_\_\_\_ BHP \_\_\_\_\_ OV \_\_\_\_\_ TS \_\_\_\_\_

ACCESSORIES REQ'D. \_\_\_\_\_

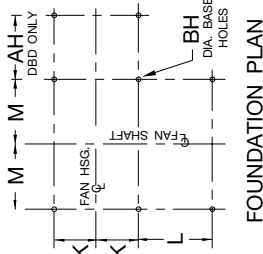

FOUNDATION PLAN

- NOTES:  
1. DISCHARGE ANGLES ARE INCLUDED ON ALL DISCHARGES.  
2. "CW" ROTATION IS SHOWN. "COW" ROTATION IS SIMILAR BUT OPPOSITE.  
3. FOR FANS WITH INLET BOX AT 90 DEGREES OR 270 DEGREES, USE "BAU" DISCHARGE DIMENSION "DF" FOR CENTERLINE HEIGHT.

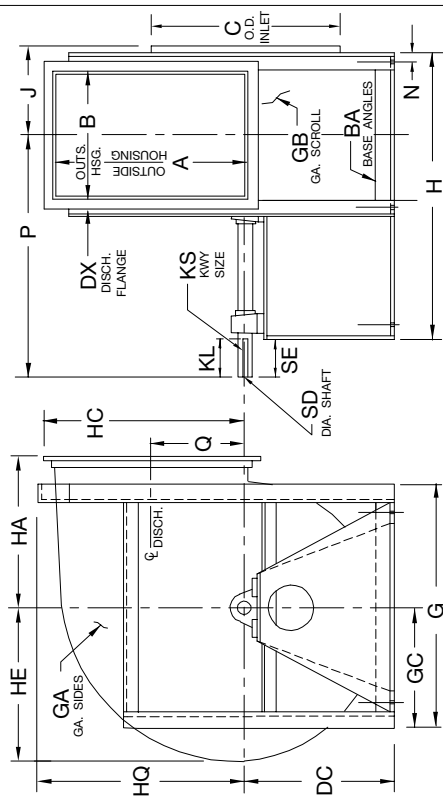

CW THD

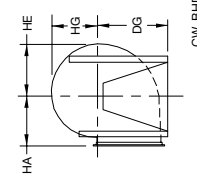

CW BAU

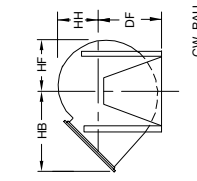

CW UBD

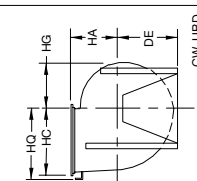

CW TAU

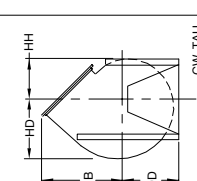

CW TAD

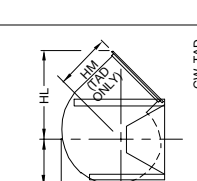

CW DBD

SIZE	A	AH	B	BA	BH	C	DA	DB	DC	DD	DE	DF	DG	DX	G	GA	GB	GC	H	HA	HB	HE	HP	SE	SIZE
365	39.00	22.25	29.13	3.0 x 4.0	0.81	38.50	29.00	29.25	29.50	31.50	33.50	35.50	41.50	2.00	49.00	0.25	0.25	24.50	60.13	29.00	49.31	365	365		
402	42.94	25.44	32.06	3.5 x 5.0	0.81	42.44	32.00	31.75	33.00	35.25	37.00	39.50	46.00	2.00	52.50	0.25	0.25	26.25	66.13	32.00	54.25	402	402		
445	47.44	28.94	35.44	4.0 x 6.0	0.81	46.88	35.58	36.25	35.50	38.50	40.00	43.25	50.50	2.00	57.50	0.25	0.25	28.75	74.50	35.38	59.81	445	445		
490	52.25	31.25	38.88	4.0 x 6.0	0.81	51.63	39.00	38.75	39.00	42.25	44.00	47.50	55.75	2.00	62.50	0.25	0.25	31.25	79.88	39.00	65.75	490	490		
542	57.69	33.94	43.13	4.0 x 6.0	0.81	57.13	43.06	42.25	43.50	46.50	49.00	52.25	61.25	2.50	68.00	0.25	0.25	34.00	84.13	43.06	72.81	542	542		
600	63.81	37.06	47.56	4.0 x 6.0	0.81	63.13	47.69	45.00	48.00	51.25	54.00	57.50	67.25	2.50	74.00	0.25	0.25	37.00	91.63	47.69	80.44	600	600		
660	70.00	40.25	52.44	4.0 x 6.0	0.81	69.38	52.44	49.50	52.50	55.75	59.00	63.00	73.75	2.50	81.00	0.25	0.25	40.50	98.50	52.44	88.19	660	660		
730	77.50	43.75	57.81	4.0 x 6.0	0.81	76.75	58.00	54.25	57.00	61.75	64.50	69.50	81.25	2.50	89.00	0.25	0.25	44.50	106.88	58.00	97.38	730	730		
807	85.69	48.19	63.88	4.0 x 6.0	0.81	84.88	64.19	59.50	63.00	67.50	72.00	76.50	89.50	2.50	96.50	0.25	0.25	48.25	115.88	64.19	107.56	807	807		
890	94.38	51.38	70.25	4.0 x 6.0	0.81	93.38	70.00	65.50	69.25	73.75	78.25	85.00	98.25	2.50	107.50	0.25	0.25	53.75	125.25	70.00	117.81	890	890		

SIZE	HC	HD	HE	HF	HG	HH	HL	HM	HN	HP	HQ	KL	KS	L	M	N	P	Q	SD	SE	SIZE
365	40.75	33.69	31.63	29.75	27.88	26.00	55.88	38.31	42.75	19.56	16.69	9.0	0.88 x 0.44	23.00	18.63	1.88	51.56	19.25	3.437	10.0	365
402	44.69	37.13	34.81	32.75	30.69	28.63	60.44	40.69	47.69	22.06	18.69	10.0	0.88 x 0.44	24.50	19.88	2.38	56.06	21.25	3.437	11.0	402
445	49.19	41.06	38.38	36.13	33.88	31.63	67.13	45.75	53.19	24.75	20.88	10.0	1.00 x 0.50	28.00	21.38	2.88	61.75	23.50	3.937	11.0	445
490	54.00	45.00	42.31	39.81	37.31	34.81	73.00	49.25	58.00	26.44	22.56	11.0	1.00 x 0.50	30.00	23.88	2.88	66.44	25.88	3.937	12.0	490
542	59.94	49.94	46.81	44.06	41.31	38.56	80.31	53.69	63.44	28.56	24.89	11.0	1.00 x 0.50	30.00	26.63	2.88	68.56	28.63	4.437	12.0	542
600	66.06	55.13	51.81	48.75	45.69	42.63	87.69	58.25	69.56	30.81	26.94	12.0	1.25 x 0.63	33.00	29.63	2.88	74.81	31.69	4.937	13.0	600
660	72.25	60.56	56.94	53.50	50.06	46.63	95.50	62.88	75.75	33.25	29.38	12.0	1.25 x 0.63	35.00	32.63	2.88	79.25	34.75	4.937	13.0	660
730	79.75	67.06	63.00	59.25	55.50	51.75	104.88	68.50	83.25	35.94	32.06	13.5	1.25 x 0.63	38.00	36.63	2.88	86.44	38.50	5.437	14.5	730
807	87.94	74.19	69.63	65.50	61.38	57.25	114.38	73.81	91.44	38.94	35.06	13.5	1.25 x 0.63	41.00	40.38	2.88	92.44	42.63	5.437	14.5	807
890	96.63	81.69	76.75	72.19	67.63	63.06	126.00	81.56	100.13	42.13	38.25	14.0	1.50 x 0.75	44.00	45.88	2.88	99.13	46.94	5.937	15.0	890

DIMENSIONS ARE NOT TO BE USED FOR CONSTRUCTION. CERTIFIED DRAWINGS AVAILABLE UPON REQUEST.

"BCE", "BAE", "BC", "BAF" & "NFC" ARR. 3 DWDI NON-ROTATABLE CLASS I & II	
	TWIN CITY FAN & BLOWER
	MINNEAPOLIS, MINNESOTA
JOB:	DRAWN 5-5-94
LOC.	REVISED 7-15-05
ENG./ARCH.	DWG. NO. AC14987D
CERT. BY:	
S.O. NO.	
SIZE	DISCH. ROT. UNIT NO.
CFM	SP RPM BHP OV TS
ACCESSORIES REQ'D.	

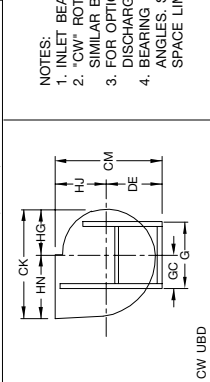
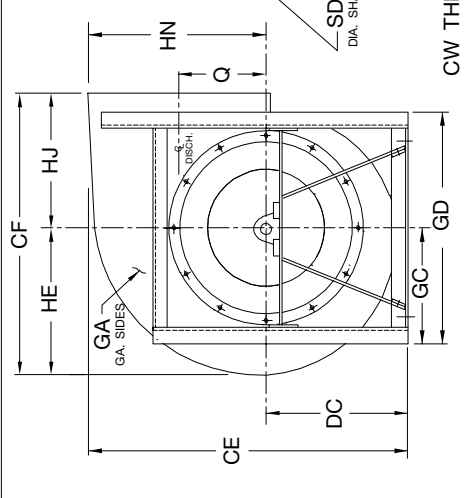
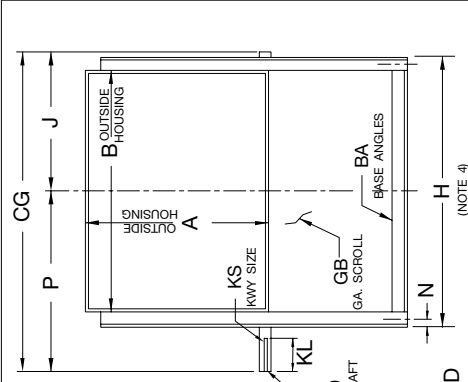
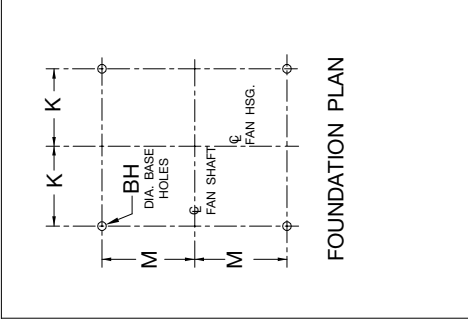

- NOTES:**
1. INLET BEARING BAR SUPPORTS ARE REMOVABLE.
  2. "CW" ROTATION IS SHOWN. "CCW" ROTATION IS SIMILAR BUT OPPOSITE.
  3. FOR OPTIONAL FLANGED OUTLET AND DOWNBLAST DISCHARGE SEE DWG. AC14895.
  4. BEARING BAR SUPPORTS MAY EXTEND BEYOND BASE ANGLES. SEE DWG. AC100648 FOR DIMENSIONS IF SPACE LIMITATIONS ARE REQUIRED FOR MOUNTING FAN.

SIZE	A	B	BA	BH	CG	CE	CF	CG	CL I	CL II	CJ	CK	CM	DC	DE	DG	G	GA	GB	GC	SIZE
122	13.00	17.44	1.5 x 1.5	0.44	23.19	19.81	26.69	28.63	24.31	22.25	20.75	10.25	11.50	15.00	19.75	14	14	9.88	122		
135	14.31	19.44	1.5 x 1.5	0.44	25.50	21.88	28.69	30.63	26.50	24.50	23.00	11.25	12.75	16.25	21.00	14	14	10.50	135		
150	15.88	21.44	1.5 x 1.5	0.44	28.06	24.32	33.13	33.13	29.38	27.19	25.44	12.25	14.00	18.00	22.75	14	14	11.38	150		
165	17.44	23.56	1.5 x 2.0	0.44	30.88	26.76	35.25	35.62	32.00	29.88	27.88	13.50	15.25	19.50	24.25	14	14	12.13	165		
182	19.38	26.00	1.5 x 2.0	0.44	34.06	29.69	38.13	38.50	35.31	33.13	30.75	14.75	16.75	21.50	26.00	12	14	13.00	182		
200	21.19	28.50	1.5 x 2.0	0.56	37.38	32.62	40.63	42.12	38.69	36.31	33.56	16.25	18.25	23.50	28.00	12	14	14.00	200		
222	23.56	31.63	2.0 x 2.0	0.56	41.50	36.25	44.62	46.88	42.81	40.31	37.69	18.00	20.50	26.00	31.25	12	14	15.63	222		
245	25.94	34.81	2.0 x 2.0	0.56	45.88	40.00	49.62	50.75	46.75	44.38	41.50	20.00	22.50	28.25	33.50	12	14	16.75	245		
270	28.63	38.25	2.0 x 2.0	0.56	50.56	44.13	53.00	54.75	51.44	49.00	45.69	22.00	24.75	31.00	36.00	12	14	18.00	270		

SIZE	GD	H	HE	HG	HJ	HN	J	J	CL I	CL II	K	KL	KS	CL I	KS	M	N	P	P	CL I	P	Q	SD	CL I	SD	CL II	SIZE
122	18.50	20.50	10.56	9.31	9.25	12.94	11.44	12.38	9.63	3.00	.25 x .13	.38 x .19	6.75	0.63	15.25	16.25	6.44	1.187	1.437	122							
135	19.75	22.50	11.63	10.25	10.25	14.25	12.44	13.38	10.63	3.00	.25 x .13	.38 x .19	7.38	0.63	16.25	17.25	7.13	1.187	1.687	135							
150	21.50	24.50	12.88	11.38	11.44	15.81	14.38	14.38	11.63	3.50	.38 x .19	.50 x .25	8.25	0.63	18.75	18.75	7.88	1.437	1.687	150							
165	24.25	27.63	14.13	12.50	12.63	17.38	15.44	15.56	12.94	3.50	.38 x .19	.50 x .25	8.75	0.88	19.81	20.06	8.69	1.437	1.937	165							
182	26.00	30.00	15.68	13.81	14.00	19.31	16.63	16.75	14.13	4.00	.38 x .19	.50 x .25	9.63	0.88	21.50	21.75	9.63	1.687	1.937	182							
200	28.00	32.50	17.31	15.19	15.31	21.13	17.78	18.56	15.38	4.00	.38 x .19	.50 x .25	10.63	0.88	22.75	23.56	10.56	1.687	2.187	200							
222	31.25	35.63	19.06	16.81	17.19	23.50	19.56	20.63	16.94	4.50	.50 x .25	.63 x .31	11.75	0.88	25.06	26.25	11.75	1.937	2.437	222							
245	33.50	38.88	21.00	18.50	19.00	25.88	21.81	22.31	18.56	5.00	.50 x .25	.63 x .31	12.88	0.88	27.81	28.44	12.94	2.187	2.437	245							
270	36.00	42.25	23.19	20.44	20.94	28.56	23.50	24.31	20.25	5.00	.50 x .25	.63 x .31	14.13	0.88	29.50	30.44	14.25	2.187	2.687	270							

DIMENSIONS ARE SUBJECT TO CHANGE. CERTIFIED DRAWINGS AVAILABLE UPON REQUEST.

"BAE", "BC", "BAF" & "NFC" ARR. NO. 3 DWDI NON-ROTATABLE  
CLASS I & II

**TWIN CITY FAN & BLOWER**  
MINNEAPOLIS, MINNESOTA 55442

DRAWN 5-5-94  
REVISED 1-30-07  
DWG. NO. AC14968F

JOB:

LOC.

ENG./ARCH.

CERT. BY:

S.O. NO.

SIZE	DISCH.	ROT.	UNIT NO.
CFM	SP	RPM	BHP
ACCESSORIES REQ'D.			

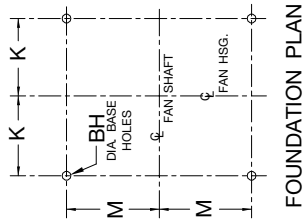

FOUNDATION PLAN

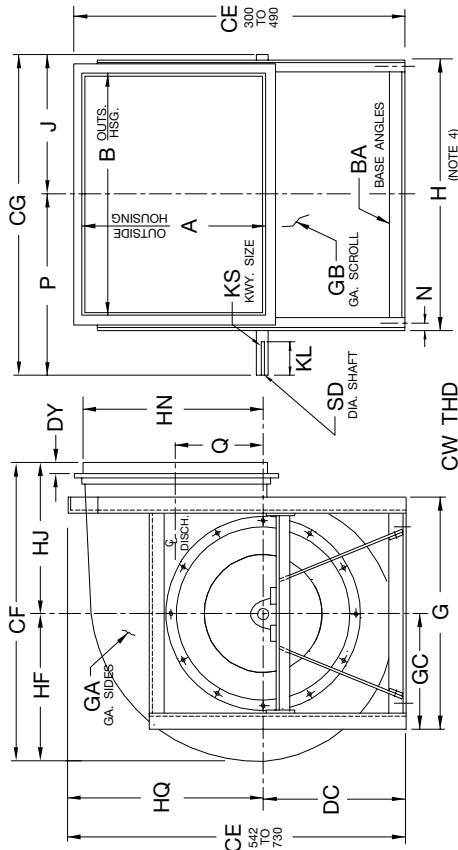

CW THD

- NOTES:  
1. INLET BEARING BAR SUPPORTS ARE REMOVABLE. ROTATIONS SHOWN. "CCW" ROTATION IS SIMILAR TO "CW".  
2. FOR OPTIONAL FLANGED OUTLET CONNECTION AND DOWNBLAST DISCHARGE SEE AC14896.  
3. BEARING BAR SUPPORTS MAY EXTEND BEYOND BASE ANGLES. SEE AC1000648 FOR DIMENSIONS IF SPACE LIMITATIONS ARE REQUIRED FOR MOUNTING FAN.

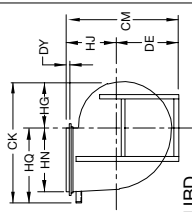

CW UBD

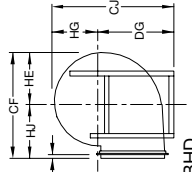

CW BHD

SIZE	A	B	BA	BH	CE	CF	CG CL I	CG CL II	CJ	CK	CM	DC	DE	DG	DY	G	GA	GB	GC
300	31.81	42.69	2.5x2.5	0.56	57.75	49.06	59.13	59.13	57.00	56.00	51.81	24.50	28.50	34.25	1.25	41.00	10	12	20.50
330	35.13	46.69	2.5x2.5	0.56	63.56	54.13	63.13	63.13	62.25	61.56	56.75	27.00	31.00	37.25	1.50	44.00	10	12	22.00
365	38.89	51.81	2.5x2.5	0.56	69.63	60.00	68.88	68.88	68.75	67.88	62.00	29.50	33.50	41.00	1.50	48.00	10	12	24.00
402	42.63	57.19	3.0x3.0	0.81	77.06	66.19	74.13	74.13	76.06	74.62	68.50	33.00	37.00	45.50	1.50	52.50	10	12	26.25
445	47.13	63.13	3.0x3.0	0.81	84.06	73.13	80.00	80.00	83.75	82.31	74.88	35.50	40.00	50.00	1.50	56.50	10	12	28.25
490	51.94	69.44	3.0x3.0	0.81	92.88	80.69	88.00	88.00	91.94	91.07	82.50	39.00	44.00	54.75	1.50	61.50	10	12	30.75
542	57.38	76.94	3.0x4.0	0.81	103.25	89.25	94.75	95.69	101.44	100.94	91.56	43.50	49.00	60.25	1.50	67.00	10	12	33.50
600	63.50	85.00	3.0x4.0	0.81	113.75	98.88	107.07	108.63	111.81	111.31	101.19	48.00	54.00	62.25	1.50	73.00	10	12	36.50
660	69.69	93.69	3.5x5.0	0.81	124.75	108.75	115.81	117.44	123.19	122.19	110.94	52.50	59.00	73.25	1.50	80.00	10	12	40.00
730	77.25	103.38	3.5x5.0	0.81	136.75	120.38	128.00	128.00	136.13	135.13	122.00	57.00	64.50	80.75	1.50	88.00	10	10	44.00

SIZE	H	HE	HG	HU	HN	HQ	J CL I	J CL II	K	KL	KS CL I	KS CL II	M	N	P CL I	P CL II	Q	SD CL I	SD CL II
300	47.75	25.75	22.75	23.31	31.75		26.25	26.25	22.75	5.50	.63x.31	.63x.31	15.88	1.13	32.88	32.88	15.81	2.437	2.437
330	51.75	28.38	25.00	25.75	35.06		28.25	28.25	24.75	5.50	.63x.31	.63x.31	17.38	1.13	34.88	34.88	17.50	2.437	2.437
365	56.88	31.50	27.75	28.50	38.63		31.13	31.13	27.31	5.50	.63x.31	.63x.31	18.88	1.13	37.75	37.75	19.25	2.687	2.687
402	63.25	34.69	30.56	31.50	42.56		33.50	33.81	30.25	6.00	.63x.31	.63x.31	20.88	1.38	40.63	40.94	21.25	2.437	2.687
445	69.13	38.25	33.75	34.88	47.06		36.44	36.56	33.19	6.00	.63x.31	.75x.38	22.88	1.38	43.56	43.81	23.50	2.437	2.937
490	75.50	42.19	37.19	38.50	51.88		39.94	41.13	36.38	7.00	.63x.31	.88x.44	25.38	1.38	48.06	49.44	25.88	2.687	3.437
542	85.00	46.69	41.19	42.56	57.31	59.75	43.75	44.19	40.63	8.00	.75x.38	.88x.44	27.63	1.88	51.00	51.50	28.63	2.937	3.437
600	93.00	51.69	45.56	46.69	63.44	65.75	48.88	49.63	44.63	8.00	.88x.44	1.00x.50	30.63	1.88	58.19	59.00	31.69	3.437	3.937
660	103.75	56.81	49.94	51.94	69.63	72.25	53.25	54.06	49.63	8.00	.88x.44	1.00x.50	33.13	2.38	62.56	63.38	34.75	3.437	3.937
730	113.38	62.88	55.38	57.50	77.13	79.75	58.81	58.81	54.31	9.00	1.00x.50	1.00x.50	37.13	2.38	69.19	69.19	38.50	3.937	3.937

DIMENSIONS ARE SUBJECT TO CHANGE. CERTIFIED DRAWINGS AVAILABLE UPON REQUEST.



**TWIN CITY FAN & BLOWER**  
MINNEAPOLIS, MINNESOTA

**JOB:**  
**LOC.**  
**ENG./ARCH.**  
**CERT. BY:**  
**S.O. NO.**

DRAWN 8-16-82  
REVISED 7-15-05  
DWG. NO. AC9258E

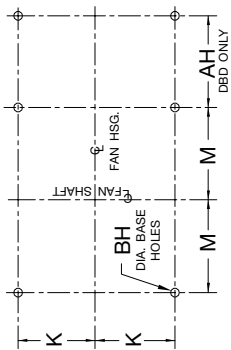

**FOUNDATION PLAN**

- NOTES:  
1. FOR SUP. CONNECTION ON DISCHARGE, CONTACT FACTORY FOR DWG. AC18864.  
2. INLET BEARING BAR SUPPORTS ARE REMOVABLE.  
3. "CW" ROTATION IS SHOWN. "CCW" ROTATION IS SIMILAR BUT OPPOSITE.  
4. FRAME SUPPORTS VARY IN CONSTRUCTION BY SIZE AND BY DISCHARGE POSITION.  
5. BEARING BAR SUPPORTS MAY EXTEND BEYOND BASE ANGLES. SEE DWG. AC1000648 FOR DIMENSIONS IF SPACE LIMITATIONS ARE REQUIRED FOR MOUNTING FAN.

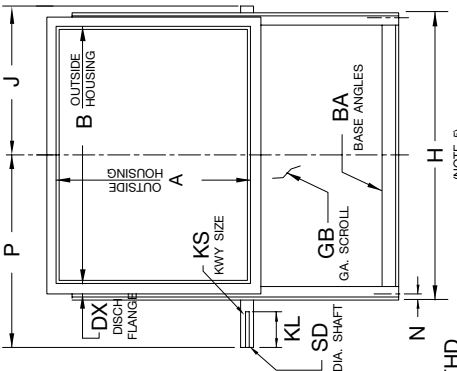

**CW THD**

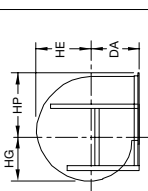
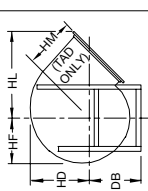
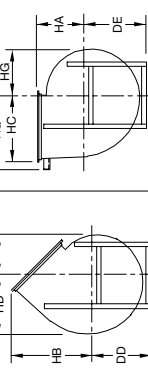

**CW BAU**

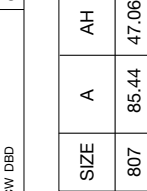
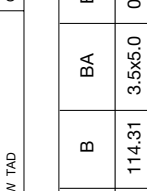
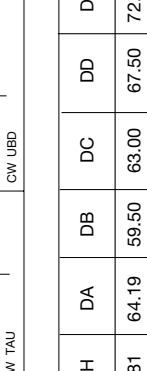

SIZE	A	AH	B	BA	BH	DA	DB	DC	DD	DE	DF	DG	DX	G	GA	GB	GC	GD	H	HA	HB	HC	SIZE
807	85.44	47.06	114.31	3.5x5.0	0.81	64.19	59.50	63.00	67.50	72.00	76.50	89.00	2.50	95.50	10	47.75	95.50	124.38	64.19	107.50	87.81	807	
890	94.13	50.25	126.13	3.5x5.0	0.81	70.00	65.50	69.25	73.75	78.25	85.00	97.81	2.50	106.50	7	53.25	106.50	136.13	70.00	117.75	96.50	890	
982	104.00	53.75	139.19	4.0x6.0	0.81	77.75	71.50	76.50	80.00	86.50	92.00	108.25	2.50	122.00	7	61.00	122.00	151.25	77.75	130.13	106.31	982	

SIZE	HD	HE	HF	HG	HH	HL	HM	HP	HQ	J	J	K	KL	KS	M	N	P	P	Q	SD	SD	SIZE
										CL I	CL II						CL I	CL II	CL I	CL II		
807	74.00	69.50	65.38	61.25	57.13	113.69	73.00	90.31	87.75	64.31	65.56	59.81	9.0	1.00x.50	40.88	2.38	74.69	75.44	42.63	3.937	4.437	807
890	81.56	76.63	72.06	67.50	62.94	125.38	80.75	99.00	96.50	70.19	71.50	65.69	9.0	1.00x.50	46.38	2.38	80.56	82.00	46.94	3.937	4.437	890
982	90.06	84.63	79.56	74.50	69.44	140.06	91.75	109.75	106.75	77.81	78.44	72.75	9.0	1.25x.63	53.13	2.88	88.31	88.88	51.81	4.937	5.437	982

DIMENSIONS ARE SUBJECT TO CHANGE. CERTIFIED DRAWINGS AVAILABLE UPON REQUEST.

"BCE", "BAE", "BC" & "BAF" ARR. 3F. DWDI, CLASS I  
NON-ROTATABLE

CW - POSITION "Z"  
CCW - POSITION "W"

**TWIN CITY FAN & BLOWER**  
MINNEAPOLIS, MINNESOTA

DRAWN 10-27-98  
REVISED 7-15-05  
DWG. NO. AC16026B

**JOB:**  
**LOC.**  
**ENG./ARCH.**  
**CERT. BY:**  
**S.O. NO.**

DISCH. ROT. UNIT NO.  
CFM SP RPM BHP OV TS  
ACCESSORIES REQ'D.

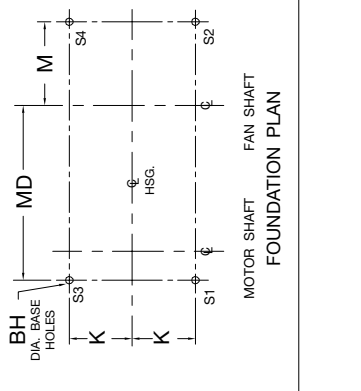

**NOTES:**  
1. "CW" ROTATION, MOTOR POSITION "Z" SHOWN. "CCW" ROTATION, MOTOR POSITION "W" IS SIMILAR BUT OPPOSITE.  
2. STANDARD ARR. 3F MOTOR LOCATION ON RIGHT FOR "CW" ROTATION UNITS AND ON LEFT FOR "CCW" ROTATION UNITS AND ON RIGHT FOR "CCW" ROTATION, DIMENSION "FR" EQUALS MAX. MOTOR FRAME.  
3. FOR OPTIONAL FLANGED OUTLET, CONTACT FACTORY FOR DWG. AC16038.  
4. SEE ES4-98 FOR POINT LOADS AT LOCATION "S1," "S2," ETC.

**NOTE: CONTACT FACTORY FOR BHD AND OTHER UBD ORIENTATIONS.**

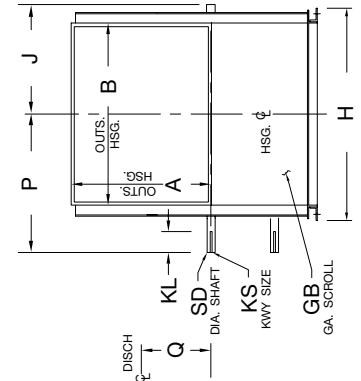

CW THD

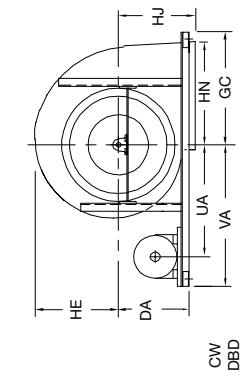

CW DBD

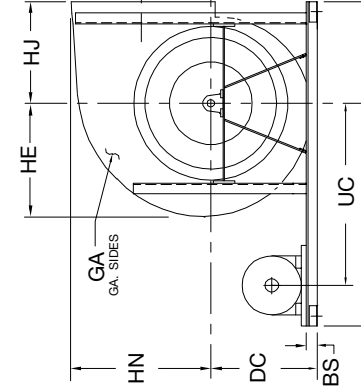

CW UBD

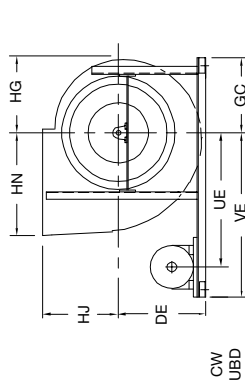

SIZE	A	B	BH	BS	BS	DA	DC	DE	FR	GA	GB	GC DBD	GC THD	GC UBD	H	H	H	H	HE	HG	HJ	HJ	HN	SIZE
122	13.00	17.44	0.69	4.00	12.38	12.38	12.38	184T	14	14	16.00	9.13	11.38	28.00	24.00	10.56	9.31	13.88	9.25	12.94	122			
135	14.31	19.44	0.69	4.00	13.00	13.00	13.00	184T	14	14	17.25	9.75	12.00	30.00	26.00	11.63	10.25	14.50	10.25	14.25	135			
150	15.88	21.44	0.69	4.00	13.88	13.88	13.88	213T	14	14	18.88	10.63	12.88	32.00	28.00	12.88	11.38	15.38	11.44	15.81	150			
165	17.44	23.56	0.69	4.00	14.63	14.63	15.13	215T	14	14	20.38	12.13	13.63	34.13	30.13	14.13	12.50	16.13	12.63	17.38	165			
182	19.38	26.00	0.69	4.00	15.50	15.50	16.69	254T	12	14	22.38	13.00	14.50	36.50	32.50	15.69	13.81	17.00	14.00	19.31	182			
200	21.19	28.50	0.69	4.00	16.50	16.50	18.31	254T	12	14	24.13	14.00	15.50	39.00	35.00	17.31	15.19	18.00	15.31	21.13	200			
222	23.56	31.63	0.69	5.00	18.63	18.63	20.06	254T	12	14	27.00	15.63	17.13	42.38	40.38	19.06	16.81	20.13	17.19	23.50	222			
245	25.94	34.81	0.69	5.00	19.75	19.75	22.00	256T	12	14	29.38	18.25	18.25	45.63	43.63	21.00	18.50	21.25	19.00	25.88	245			
270	28.63	38.25	0.69	5.00	21.00	21.44	24.19	256T	12	14	32.13	19.50	19.50	49.00	47.00	23.19	20.44	22.50	20.94	28.56	270			

SIZE	J	K	K	KL	KL	KS	M	M	M	M	MD	MD	MD	P	Q	SD	UA	UC	UE	VA	VC	VE	SIZE
122	11.44	12.75	10.63	3.00	25x.13	13.00	6.13	8.38	23.00	24.25	26.13	15.25	6.44	1.187	19.63	20.88	22.75	26.00	27.25	29.13	122		
135	12.44	13.75	11.63	3.00	25x.13	14.25	6.75	9.00	23.88	25.25	27.38	16.25	7.13	1.187	20.50	21.88	24.00	26.88	28.25	30.38	135		
150	14.38	14.75	12.63	3.50	38x.19	15.88	7.63	9.88	28.13	29.63	32.00	18.75	7.88	1.437	23.63	25.13	27.50	31.13	32.63	35.00	150		
165	15.44	15.81	13.69	3.50	38x.19	17.38	8.13	10.63	29.25	30.88	33.13	19.81	8.69	1.487	24.75	26.38	28.63	32.25	33.88	36.13	165		
182	16.63	17.00	14.88	4.00	38x.19	19.38	10.00	11.50	34.25	36.00	39.00	21.50	9.63	1.687	28.38	30.13	33.13	37.25	39.00	42.00	182		
200	17.88	18.25	16.13	4.00	38x.19	21.13	11.00	12.50	35.50	37.75	40.75	22.75	10.56	1.687	29.63	31.88	34.88	38.50	40.75	43.75	200		
222	19.56	19.94	18.31	4.50	50x.25	24.00	12.63	14.13	37.25	39.50	43.13	25.06	11.75	1.937	31.38	33.63	37.25	40.25	42.50	46.13	222		
245	21.81	21.56	19.94	5.00	50x.25	26.38	15.25	15.25	38.88	41.38	45.25	27.81	12.94	2.187	33.00	35.50	39.38	41.88	44.38	48.25	245		
270	23.50	23.25	21.63	5.00	50x.25	29.13	16.50	16.50	40.75	43.50	47.63	29.50	14.25	2.187	34.88	37.63	41.75	43.75	46.50	50.63	270		

DIMENSIONS ARE SUBJECT TO CHANGE. CERTIFIED DRAWINGS AVAILABLE UPON REQUEST.



**JOB:**  
**LOC.**  
**ENG./ARCH.**  
**CERT. BY:**  
**S.O. NO.**

UNIT NO.  
 BHP  
 OV  
 TS

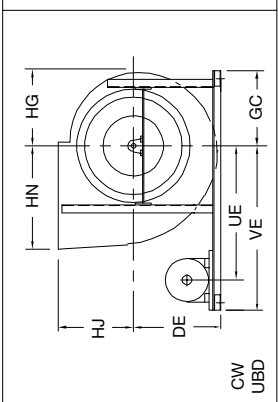
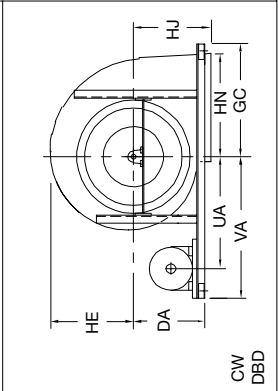
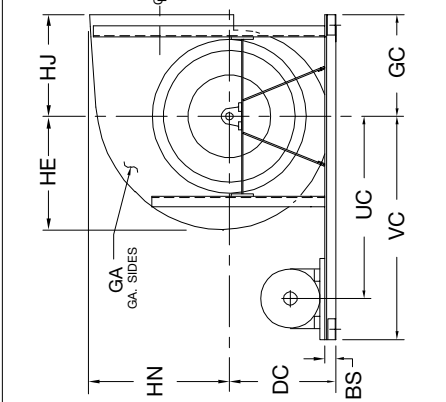
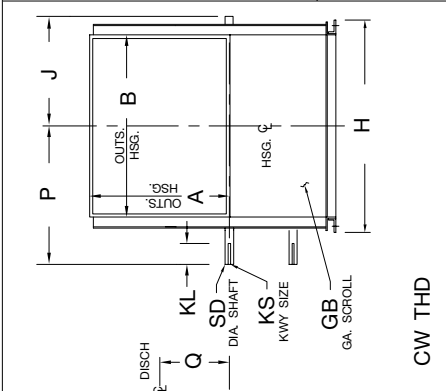

- NOTES:**  
 1. "CW" ROTATION, MOTOR POSITION "Z" SHOWN.  
 "CCW" ROTATION, MOTOR POSITION "W" IS  
 SIMILAR BUT OPPOSITE.  
 2. STANDARD ARR. 3F MOTOR LOCATION ON LEFT  
 FOR "CW" ROTATION UNITS AND ON RIGHT  
 FOR "CCW" ROTATION. DIMENSION "FR"  
 EQUALS MAX. MOTOR FRAME  
 3. FOR OPTIONAL FLANGED OUTLET, SEE DWG.  
 AC16044.  
 4. SEE ES4-98 FOR POINT LOADS AT LOCATION  
 "S1," "S2," ETC.

**NOTE: CONTACT FACTORY FOR BHD AND  
 OTHER UBD ORIENTATIONS.**

SIZE	A	B	BH	BS	DA	DC	DE	FR	GA	GB	GC	GC	GC	H	H	H	HE	HG	HJ	HJ	HU	HN	SIZE
122	13.00	17.44	0.69	4.00	12.38	12.38	12.38	215T	14	14	16.00	9.13	11.38	28.00	24.00	10.56	9.31	13.88	9.25	12.94	12.94	122	
135	14.31	19.44	0.69	4.00	13.00	13.00	13.00	254T	14	14	17.25	9.75	12.00	30.00	26.00	11.63	10.25	14.50	10.25	14.25	14.25	135	
150	15.88	21.44	0.69	4.00	13.88	13.88	13.88	254T	14	14	18.88	10.63	12.88	32.00	28.00	12.88	11.38	15.38	11.44	15.81	15.81	150	
165	17.44	23.56	0.69	4.00	14.63	14.63	15.13	256T	14	14	20.38	12.13	13.63	34.13	30.13	14.13	12.50	16.13	12.63	17.38	17.38	165	
182	19.38	26.00	0.69	4.00	15.50	15.50	16.69	284T	12	14	22.38	13.00	14.50	36.50	32.50	15.69	13.81	17.00	14.00	19.31	18.2	182	
200	21.19	28.50	0.69	4.00	16.50	16.50	18.31	284T	12	14	24.13	14.00	15.50	39.00	35.00	17.31	15.19	18.00	15.31	21.13	21.13	200	
222	23.56	31.63	0.69	5.00	18.63	18.63	20.06	286T	12	14	27.00	15.63	17.13	42.38	40.38	19.06	16.81	20.13	17.19	23.50	22.2	222	
245	25.94	34.81	0.69	5.00	19.75	19.75	22.00	324T	12	14	29.38	18.25	18.25	45.63	43.63	21.00	18.50	21.25	19.00	25.88	24.5	245	
270	28.63	38.25	0.69	5.00	21.00	21.44	24.19	326T	12	14	32.13	19.50	19.50	49.00	47.00	23.19	20.44	22.50	20.94	28.56	27.0	270	

SIZE	J	K	K	KL	KS	M	M	M	M	MD	MD	MD	P	Q	SD	UA	UC	UE	VA	VC	VE	SIZE
122	12.38	12.75	10.63	3.00	.38x.19	13.00	6.13	8.38	26.13	29.25	16.25	6.44	1.437	6.44	21.63	22.88	24.75	29.13	30.38	32.25	122	
135	13.38	13.75	11.63	3.00	.38x.19	14.25	6.75	9.00	30.63	32.00	17.25	7.13	1.687	7.13	24.75	26.13	28.25	33.63	35.00	37.13	135	
150	14.38	14.75	12.63	3.50	.38x.19	15.88	7.63	9.88	31.75	33.25	18.75	7.88	1.687	7.88	25.88	27.38	29.75	34.75	36.25	38.63	150	
165	15.56	15.81	13.69	3.50	.50x.25	17.38	9.13	10.63	32.88	34.50	20.06	8.69	1.937	8.69	27.00	28.63	30.88	35.88	37.50	39.75	165	
182	16.75	17.00	14.88	4.00	.50x.25	19.38	10.00	11.50	36.75	38.50	21.75	9.63	1.937	9.63	29.88	31.63	34.63	39.75	41.50	44.50	182	
200	18.56	18.25	16.13	4.00	.50x.25	21.13	11.00	12.50	38.00	40.25	23.56	10.56	2.187	10.56	31.13	33.38	36.38	41.00	43.25	46.25	200	
222	20.63	19.94	18.31	4.50	.63x.31	24.00	12.63	14.13	39.75	42.00	25.63	11.75	2.437	11.75	32.88	35.13	38.75	42.75	45.00	48.63	222	
245	22.31	21.56	19.94	5.00	.63x.31	26.38	15.25	16.50	45.00	47.50	28.44	12.94	2.437	12.94	36.63	39.13	43.00	48.00	50.50	54.38	245	
270	24.31	23.25	21.63	5.00	.63x.31	29.13	16.50	16.50	46.88	49.63	30.44	14.25	2.687	14.25	38.50	41.25	45.63	49.88	52.63	57.00	270	

DIMENSIONS ARE SUBJECT TO CHANGE. CERTIFIED DRAWINGS AVAILABLE UPON REQUEST.

"BCE", "BAE", "BC" & "BAF" ARR. 3F. DWI, CLASS II CW - POSITION "Z",  
NON-ROTATABLE CCW - POSITION "W"  
**TWIN CITY FAN & BLOWER**  
MINNEAPOLIS, MINNESOTA  
DRAWN 10-27-98  
REVISED 7-15-05  
DWG. NO. AC16039C

**JOB:**  
**LOC.**  
**ENG./ARCH.**  
**CERT. BY:**  
**S.O. NO.**

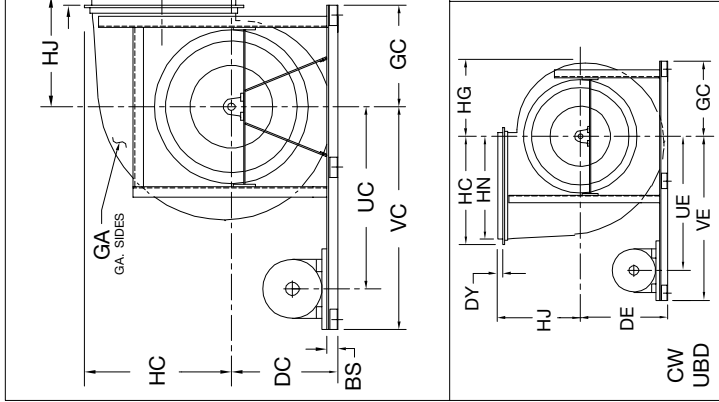
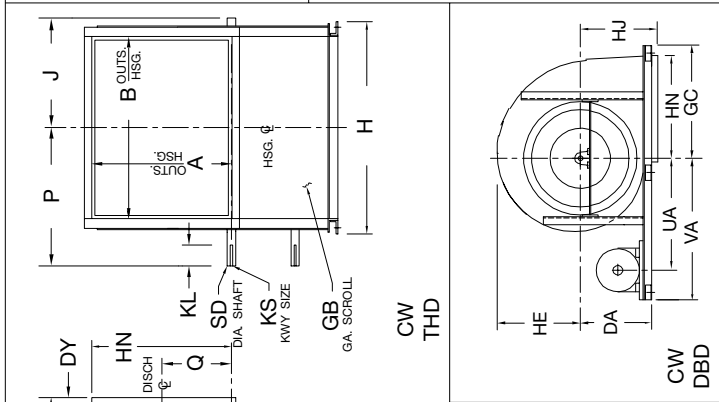
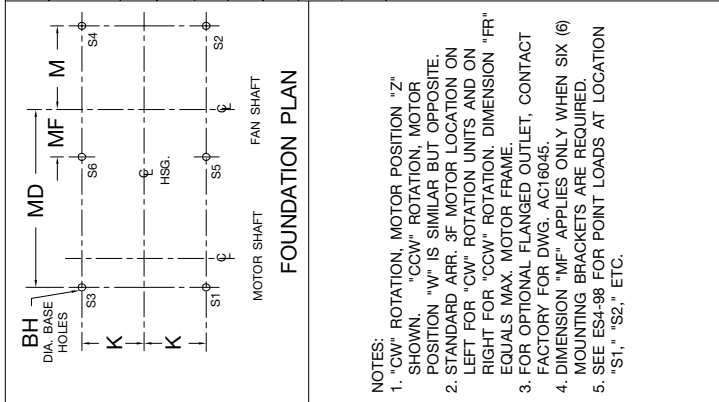

**NOTES:**  
1. "CW" ROTATION, MOTOR POSITION "Z" SHOWN. "CCW" ROTATION, MOTOR POSITION "W" IS SIMILAR BUT OPPOSITE. STANDARD ARR. 3F MOTOR LOCATION ON LEFT FOR "CW" ROTATION UNITS AND ON RIGHT FOR "CCW" ROTATION. DIMENSION "FR" EQUALS MAX. MOTOR FRAME. 3. FOR OPTIONAL FLANGED OUTLET, CONTACT FACTORY FOR DWG. AC16045. 4. DIMENSION "MF" APPLIES ONLY WHEN SIX (6) MOUNTING BRACKETS ARE REQUIRED. 5. SEE ES4-98 FOR POINT LOADS AT LOCATION "S1," "S2," ETC.

**NOTE: SEE DRAWING 16034 FOR SIZES 542-660. CONTACT FACTORY FOR BHD AND OTHER UBD ORIENTATIONS.**

SIZE	A	B	BH	BS	DA	DC	DE	DY	FR	GA	GB	GC	GC DBD	GC THD/UBD	H	H THD/UBD	H	H DBD	H	HC	HE	HG	HJ	HJ DBD	HJ THD/UBD	HN	SIZE
300	31.81	42.69	0.69	5.00	23.00	23.75	26.75	1.25	364T	10	12	35.25	21.50	51.50	53.50	21.50	33.25	25.75	33.25	22.75	24.50	24.50	23.31	31.75	300		
330	35.13	46.69	0.69	5.00	24.50	26.00	29.38	1.50	365T	10	12	38.63	23.00	55.50	57.50	23.00	36.56	28.38	36.56	25.00	26.00	26.00	25.75	35.06	330		
365	38.69	51.81	0.81	6.00	27.50	28.75	32.50	1.50	365T	10	12	42.63	25.50	62.63	62.63	25.50	40.13	31.50	40.13	27.75	29.00	29.00	28.50	38.63	365		
402	42.63	57.19	0.81	6.00	30.00	31.56	35.69	1.50	405T	10	12	46.63	27.25	68.00	68.00	27.25	44.06	34.69	44.06	30.56	31.50	31.50	31.50	42.56	402		
445	47.13	63.13	0.81	6.00	33.38	34.75	39.25	1.50	445T	10	12	51.13	29.25	73.88	73.88	29.25	48.56	38.25	48.56	33.75	34.88	34.88	34.88	47.06	445		
490	51.94	69.44	0.81	6.00	37.00	38.19	43.19	1.50	445T	10	12	55.88	31.75	80.25	80.25	31.75	53.88	42.19	53.88	37.19	38.50	38.50	38.50	51.88	490		

SIZE	J	K	K DBD	K THD/UBD	KL	KS	M	M DBD	M THD/UBD	MD	MD DBD	MD THD	MD UBD	MF	MF DBD	MF THD	MF UBD	P	Q	SD	UA	UC	UE	VA	VC	VE	SIZE
300	26.25	25.50	23.88	5.50	0.63 x 0.31	32.25	18.50	53.50	56.50	61.25	—	—	—	—	—	—	—	32.88	15.81	2.437	43.75	46.75	51.50	56.50	59.50	64.25	300
330	28.25	27.50	25.88	5.50	0.63 x 0.31	35.63	20.00	55.75	59.13	64.13	—	—	—	—	—	—	—	34.88	17.50	2.437	46.00	49.38	54.38	58.75	62.13	67.13	330
365	31.13	30.06	28.94	5.50	0.63 x 0.31	39.63	22.50	58.50	62.25	67.63	—	—	—	—	—	—	—	37.75	19.25	2.687	48.75	52.50	57.88	61.50	65.25	70.63	365
402	33.81	32.75	31.63	6.00	0.63 x 0.31	43.63	24.25	67.00	71.00	77.13	11.69	—	—	—	—	—	—	40.94	21.25	2.687	55.63	59.63	65.75	70.00	74.00	80.13	402
445	36.56	35.69	34.56	6.00	0.75 x 0.38	48.13	26.25	73.68	78.13	84.63	12.75	—	—	—	—	—	—	29.19	23.50	2.937	61.00	65.50	72.00	76.63	81.13	87.63	445
490	41.13	38.88	37.75	7.00	0.88 x 0.44	52.88	28.75	76.88	81.75	88.75	12.00	26.50	—	—	—	—	—	30.00	25.88	3.437	64.25	69.13	76.13	79.88	84.75	91.75	490

DIMENSIONS ARE SUBJECT TO CHANGE. CERTIFIED DRAWINGS AVAILABLE UPON REQUEST.

# Typical Specifications - SWSI

---

Fans shall be Type BC Backward Inclined, as manufactured by Twin City Fan & Blower, Minneapolis, Minnesota.

**PERFORMANCE** — Fans shall be tested in accordance with AMCA 210 and AMCA 300 test codes for air moving devices and shall be licensed to bear the AMCA certified ratings seal for both sound and air.

Fans shall have a sharply rising pressure characteristic extending through the operating range and continuing to rise beyond the efficiency peak to ensure quiet and stable operation. Fans shall have a non-overloading design with self-limiting horsepower characteristics and shall reach a peak in the normal selection area. All fans shall be capable of operating over the minimum pressure class limits, as specified in AMCA Standard 99-2408.

**HOUSING** — BC fan housings shall be of heavy gauge, continuously welded construction. Housings with lock seams or partially welded construction are not acceptable. Discharge flanges are to be provided for rigidity and duct connection. Housings shall be suitably braced to prevent vibration or pulsation. Housings shall have tapered spun, aerodynamically designed inlet cones or funnels providing stable flow and high rigidity.

Class I and II sizes 270 and smaller shall be of the rotatable design, convertible to 8 standard discharge configurations.

**WHEEL** — BC backward inclined wheels shall be single thickness plate type, designed for maximum efficiency and quiet operation, and shall be solid welded to the rim and back plate. Partial welding will not be acceptable on airfoil or backward inclined blades. All wheels shall be statically and dynamically balanced.

**SHAFT** — Shafts shall be AISI 1040 or 1045 hot rolled steel, accurately turned, ground, polished, and ring gauged for accuracy. Shafts shall be sized for the first critical speed of at least 1.43 times the maximum speed.

**BEARINGS** — Bearings shall be heavy duty, grease lubricated, spherical roller or adapter mounted anti-friction ball, self-aligning, pillow block type and selected for a minimum average bearing life (AFBMA L-50) in excess of 200,000 hours at the maximum fan RPM.

**DRIVE** — Motor sheaves shall be cast iron, variable pitch on applications 10 HP and smaller, and fixed pitch on 15 HP and larger. Drives and belts shall be located external to the fan casing and rated for 150% of the required motor HP.

**FINISH AND COATING** — The entire fan assembly, excluding the shaft, shall be thoroughly degreased and deburred before application of a rust-preventative primer. After the fan is completely assembled, a finish coat of paint shall be applied to the entire assembly. The fan shaft shall be coated with a petroleum-based rust protectant.

**ACCESSORIES** — When specified, accessories such as belt guards, weather covers, access doors, companion flanges, variable inlet vanes, outlet dampers, piezometer ring airflow measurement device, inlet boxes, shaft coolers, shaft seals, inlet screens, etc., shall be provided by Twin City Fan & Blower to maintain one source responsibility.

When specified, fans shall be supplied with internal or nested type variable inlet vanes for wheel diameters 16½" and larger. Cantilevered vane blades are to be used through Size 660 to minimize air performance insertion losses and noise. The operating mechanism shall be out of the inlet airstream.

**FACTORY BALANCE AND RUN TESTING** — All fan wheels shall be statically and dynamically balanced in accordance with ANSI/AMCA 204 "Balance Quality and Vibration Levels for Fans" to Fan Application Category BV-3. This corresponds to a Balance Quality Grade G6.3. All assembled fans are test run at the rated operating speed or at the maximum RPM of the fan. Vibration readings are recorded in the horizontal, vertical and axial directions on both bearings. Trim balancing is performed if necessary to maintain BV-3 vibration limits. Records shall be maintained and a written copy shall be available upon request.

**GUARANTEE** — The manufacturer shall guarantee the workmanship and materials for its BC Backward Inclined fans for at least one (1) year from startup or eighteen (18) months from shipment, whichever occurs first.

# Typical Specifications - DWDI

---

Fans shall be Type BC Backward Inclined, as manufactured by Twin City Fan & Blower, Minneapolis, Minnesota.

**PERFORMANCE** — Fans shall be tested in accordance with AMCA 210 test codes for air moving devices and shall be licensed to bear the AMCA certified ratings seal for air.

Fans shall have a sharply rising pressure characteristic extending through the operating range and continuing to rise beyond the efficiency peak to ensure quiet and stable operation. Fans shall have a non-overloading design with self-limiting horsepower characteristics and shall reach a peak in the normal selection area. All fans shall be capable of operating over the minimum pressure class limits, as specified in AMCA Standard 2408-69.

**HOUSING** — BC fan housings shall be of heavy gauge, continuously welded construction. Housings with lock seams or partially welded construction are not acceptable. Housings shall be suitably braced to prevent vibration or pulsation. Housings shall have spun, aerodynamically designed inlet cones or inlet venturies for smooth airflow into the wheels.

**WHEEL** — Wheels shall have tapered spun wheel cones or shrouds, providing stable flow and high rigidity. Wheels shall be of the non-overloading type. BC backward inclined wheels shall be single thickness plate type, continuously welded to the rim and back plate. Blades shall be designed for maximum efficiency and quiet operation. Partial welding will not be acceptable on airfoil or backward inclined blades. Smaller sizes may use extruded aluminum blades. All wheels shall be statically and dynamically balanced. The complete fan assembly shall be test balanced at the operating speed prior to shipment.

**SHAFT** — Shafts shall be AISI 1040 or 1045 hot rolled steel, accurately turned, ground, polished, and ring gauged for accuracy. Shafts shall be sized for the first critical speed of at least 1.43 times the maximum speed.

**BEARINGS** — Bearings shall be heavy duty, grease lubricated, spherical roller or adapter mounted anti-friction ball, self-aligning, pillow block type and selected for a minimum average bearing life (AFBMA L-50) in excess of 200,000 hours at the maximum fan RPM.

**DRIVE** — Motor sheaves shall be cast iron, variable pitch on applications 10 HP and smaller, and fixed pitch on 15 HP and larger. Drives and belts shall be located external to the fan casing and rated for 150% of the required motor HP.

**FINISH AND COATING** — The entire fan assembly, excluding the shaft, shall be thoroughly degreased and deburred before application of a rust-preventative primer. After the fan is completely assembled, a finish coat of paint shall be applied to the entire assembly. The fan shaft shall be coated with a petroleum-based rust protectant.

**ACCESSORIES** — When specified, accessories such as belt guards, access doors, companion flanges, variable inlet vanes, outlet dampers, piezometer ring airflow measurement device, inlet boxes, shaft coolers, shaft seals, inlet screens, etc., shall be provided by Twin City Fan & Blower to maintain one source responsibility.

When specified, fans shall be supplied with internal or nested type variable inlet vanes for wheel diameters 16½" and larger. Cantilevered vane blades are to be used through Size 660 to minimize air performance insertion losses and noise. The operating mechanism shall be out of the inlet airstream. Double width fans shall have interconnecting linkage to ensure operation in unison.

**FACTORY BALANCE AND RUN TESTING** — All fan wheels shall be statically and dynamically balanced in accordance with ANSI/AMCA 204 "Balance Quality and Vibration Levels for Fans" to Fan Application Category BV-3. This corresponds to a Balance Quality Grade G6.3. All assembled fans are test run at the rated operating speed or at the maximum RPM of the fan. Vibration readings are recorded in the horizontal, vertical and axial directions on both bearings. Trim balancing is performed if necessary to maintain BV-3 vibration limits. Records shall be maintained and a written copy shall be available upon request.

**GUARANTEE** — The manufacturer shall guarantee the workmanship and materials for its BC Backward Inclined fans for at least one (1) year from startup or eighteen (18) months from shipment, whichever occurs first.

# INDUSTRIAL & COMMERCIAL FANS

Centrifugal Fans | Utility Sets | Plenum & Plug Fans | Inline Centrifugal Fans

Mixed Flow Fans | Tubeaxial & Vaneaxial Fans | Propeller Wall Fans | Propeller Roof Ventilators

Centrifugal Roof & Wall Exhausters | Ceiling Ventilators | Gravity Ventilators | Duct Blowers

Radial Bladed Fans | Radial Tip Fans | High Efficiency Industrial Fans | Pressure Blowers

Laboratory Exhaust Fans | Filtered Supply Fans | Mancoolers | Fiberglass Fans | Custom Fans

Fans & Blowers

# Twin City



A Twin City Fan Company

**TWIN CITY FAN & BLOWER | [WWW.TCF.COM](http://WWW.TCF.COM)**

**5959 Trenton Lane N | Minneapolis, MN 55442 | Phone: 763-551-7600 | Fax: 763-551-7600**