

**UNITED**  
**CoolAir**  
All-Indoor Solutions

# CoolSpot

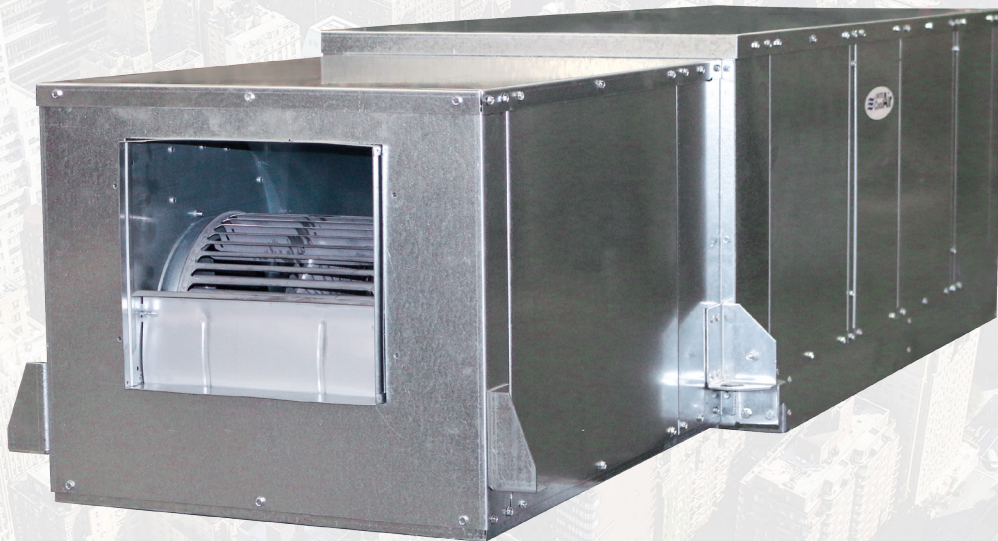

- **1 - 3 Tons Cooling Capacity**
- **Ductless Ceiling Grid Self-Contained Air Conditioning Systems or split Systems**
- **Air-Cooled, Water-Cooled, Chilled Water or Magna Cool Precision Cooling Package**

Unique Solutions for All-Indoor HVAC Projects

# Designed Specifically for Spot Cooling Applications

Cooling requirements change with space alterations and modifications in room usage. The CoolSpot is the perfect solution when localized cooling is required to meet these new conditions.

The CoolSpot eliminates the need for costly central air conditioning changes, bulky floor systems and unsightly window or wall units. The CoolSpot fits easily above the drop ceiling, replacing a tile panel, and provides even air distribution through adjustable louvers. Conventional ducted air conditioning units converted for spot cooling sacrifice efficiency or size to reach the CoolSpot's capabilities.

The CoolSpot is capable of precision cooling in areas having copiers, PC's, electronics or other heat-producing products.

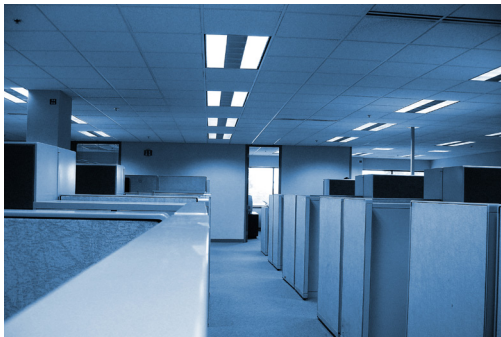

**APPLICATIONS**

- Offices
- Lobbies
- Windowless rooms that need bump-up cooling
- Resolving localized air flow situations
- High Sensible Heat Applications
- Laboratories
- Spaces requiring cooling during the heating season

## Technical Data

Tons	EAT	Air-Cooled		Water-Cooled		Chilled Water	
		Total	Sensible	Total	Sensible	Total	Sensible
1	80/67	15,100	10,700	15,700	11,200	14,060	9,220
	75/62	14,200	10,200	14,900	10,700	10,270	8,230
1-1/2	80/67	20,700	13,500	21,500	14,100	19,260	12,660
	75/62	19,200	13,350	20,000	13,800	14,080	11,335
2	80/67	25,950	20,400	27,100	21,600	24,100	15,740
	75/62	24,900	19,200	26,100	20,200	17,470	14,100
2-1/2	80/67	33,200	24,750	34,700	26,200	35,740	23,650
	75/62	31,600	23,200	33,100	24,250	26,100	21,100
3	80/67	38,900	28,300	40,100	29,700	41,100	27,300
	75/62	37,200	27,150	38,300	28,500	30,000	24,420

## Avoid Requirements that Lead to Extra Expense

### Expensive Equipment, Rigging or Permits

- Equipment can be shipped in sections
- Fits easily through standard doors, hallways, and into elevators
- Minimizes the need for crane rentals, rigging crews, and municipal permits

### Roofcurbs or Roof Penetration

- Eliminates expensive curb equipment cost
- Reduces installation labor
- Eliminates possible roof water damage

### Field Piping, Brazing, Evacuation or Charging

- Factory charged and utilizes
- Resealable Refrigerant Fittings
- Reduces installation labor
- Faster installation and commissioning

### Excessive Downtime when Replacing Old Systems

- Sectional shipments accelerate installation
- Can be installed off-hours and on weekends
- Shipment can be made to coincide with installation schedules

### Architectural Damage to Building

- Eliminates expenses for code approvals
- Requires no rigging holes through building walls
- Minimizes any type of building alteration

### Compromise in Performance With Built-to-Order Design

- Units are built to exact requirements
- Avoids purchase of excess capacity from standard product offerings
- Extensive list of configurations and options

### Equipment Damage Due to Weather

- All equipment is installed indoors
- Avoids premature replacement costs due to weather wear and/or damage
- Eliminates downtime due to severe storms

### Possibility of Theft or Vandalism

- Eliminates expensive repairs and replacements due to theft and vandalism
- Enhances building security by eliminating interruption to service
- Eliminates extra cost for cages and special alarms

### Field Testing of Installed Product

- Minimizes field testing as units are functionally tested prior to shipment
- Reduces labor and speeds installation
- Assures trouble-free start-ups

### Outdoor Servicing of Product

- Outdoor/premium service expense in extreme weather completely eliminated
- Improves reliability
- Eliminates roof safety issues

### Major Ductwork or Electrical Modifications

- Units ordered to closely match existing duct and utility locations
- Major installation, labor and time savings

### Exterior Condensing System

- Eliminates rooftop and pad installation space and cost
- Water-Cooled and Chilled Water configurations eliminate unsightly equipment outdoors

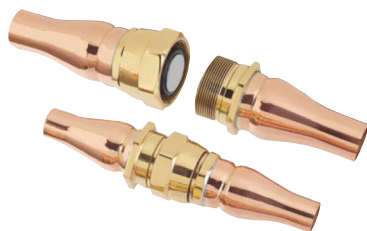

### Resealable Refrigerant Fittings

Most models feature Resealable Refrigerant Fittings. Unit sections can be shipped split or split in the field without losing the factory charge resulting in no field brazing and a total installed cost advantage.

## More Features for Better Operation

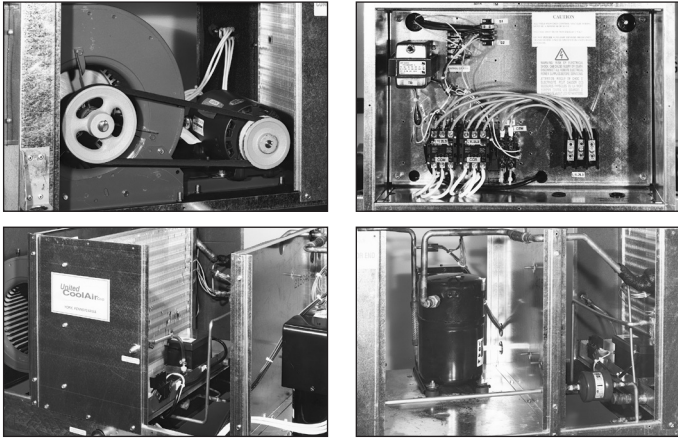

### FEATURES

- 1 to 3 Tons
- Air-Cooled, Water-Cooled, Chilled Water or MagnaCool Precision Cooling Configurations
- Ceiling Grid Mounted Package
- Drain Pan Overflow Switch
- Adjustable Supply Grille
- Return Air Grille with Integrated Filter Rack
- Completely Serviceable at Ceiling
- Evaporator Fan Speed Switch
- Sight Glass / Moisture Indicators
- Resealable Refrigerant Fittings
- High- and Low-Side Schrader Access Fittings
- Functionally Run Tested at the Factory
- Stainless Steel Drain Pan in Evaporator Section
- Direct-Drive Multi-Speed Evaporator Blower
- Belt Drive Condenser Blower
- Loss of Air Safety Switch (when electric heat is used)
- Crankcase Heaters on all Reciprocating Compressors
- Unit Rubber Vibration Isolators
- Individual Contactor for Each Motor, Compressor and Electric Heat Element
- Adjustable Expansion Valve with External Equalizer
- Filter Drier
- 1" Pleated Filter
- Blow-Through Air Flow
- Coaxial Counterflow Heat Exchanger on Water-Cooled Units
- Condenser Drain Pan on Water-Cooled Units

- Direct-drive, 2-speed evaporator blower.
- The CoolSpot is designed for quick installation and comes with a condensate pump and vibration isolators as standard equipment.
- The condenser blower on the air-cooled model is belt-driven to allow for 0.1" - 1.0" of ESP for field duct work.(Drive/motor upgrade may be required)
- A remote air-cooled condenser or condensing section is also available.
- The integral supply and return grille has an attractive white aluminum finish with adjustable louvers for even air distribution.
- The compact CoolSpot is easy to install and ships from the factory properly charged and run tested.
- All internal components are located for easy access through removable side panels, and routine maintenance is accomplished by removing adjacent ceiling tiles.
- Reciprocating compressor is standard.
- Water/glycol cooled units include a 2-way 150 psi water regulating valve. Other available valves include:
  - 3-way, 150 psi
  - 2-way, 350 psi
  - 3-way, 350 psi
 (Some valves must be mounted on exterior of cabinet)

### OPTIONS

- Electric Heat or Reheat (finned tubular)
- Heresite Coated Coils
- Steam Canister Humidifier
- Hot Gas Bypass
- Low Ambient Controls
- Freezestat
- Microprocessor Controls
- Non-Fused Disconnects
- Variety of Thermostats and Controls
- 3-way and 350 psig Water Regulating Valves
- Marvel Microprocessor Controls
- BMS Interface

## Case Study

RUTGERS UNIVERSITY

NEW BRUNSWICK, NJ

### The Challenge

Rutgers University was looking for a solution during a renovation of a dormitory. They needed A/C for the corridors, however the space above the ceiling was limited.



### The Solution

United CoolAir was able to reduce the overall height of our CoolSpot to just 17" tall. These water-cooled units fit inside 2x4 ceiling grid produced for 277U operation. Solving a challenging issue saved thousands of dollars thru a conventional ducted system.

### Other Notable Clients

- Cleveland Indians Stadium
- University of Nebraska – Lincoln (press boxes)
- Selkirk Hospital
- Falk Hospital
- CSSS Hospital
- Wells Fargo
- Lower Bucks Hospital

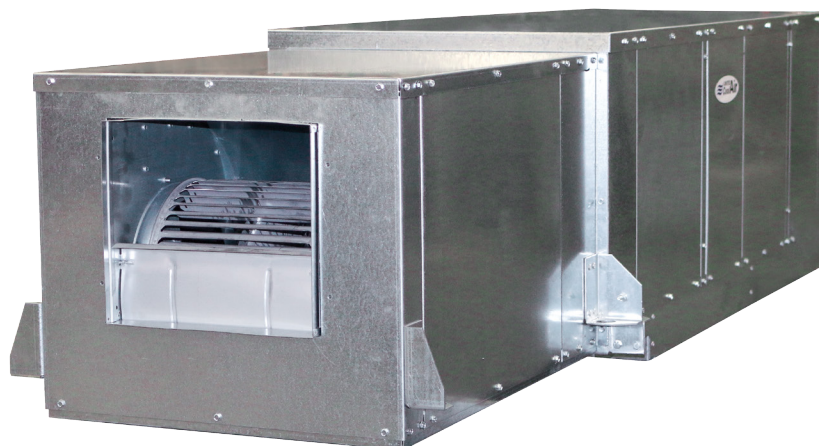

Visit [www.unitedcoolair.com](http://www.unitedcoolair.com) or call the factory at 717-843-4311 for more information

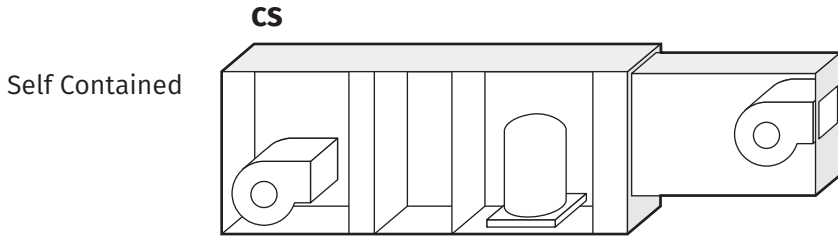

- Air-Cooled (CS) Shown
- Water-Cooled (CSW) Available
- Chilled Water (CCW) Available

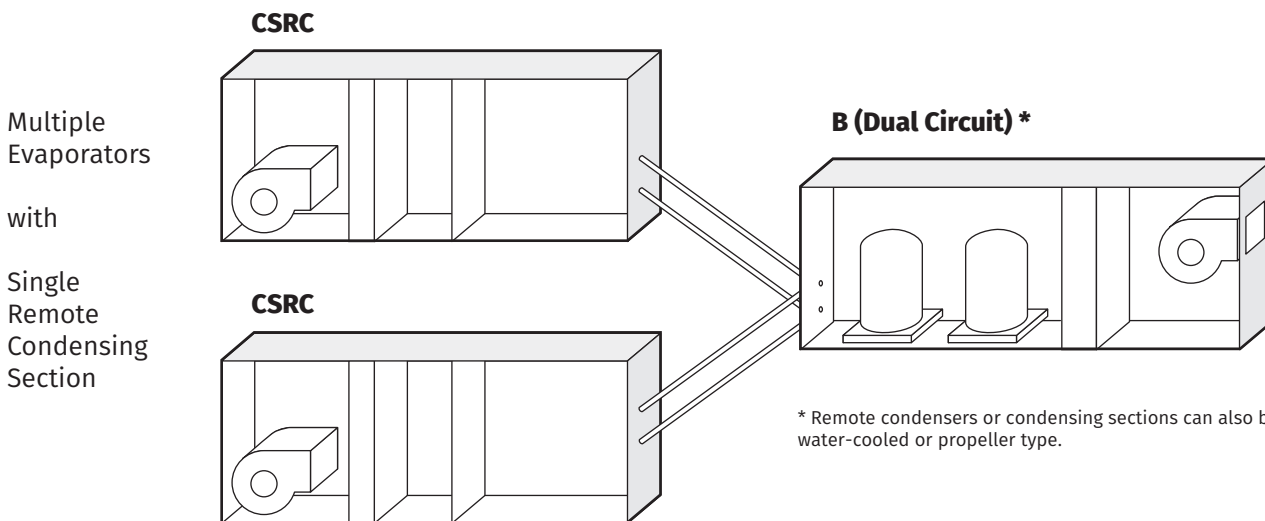
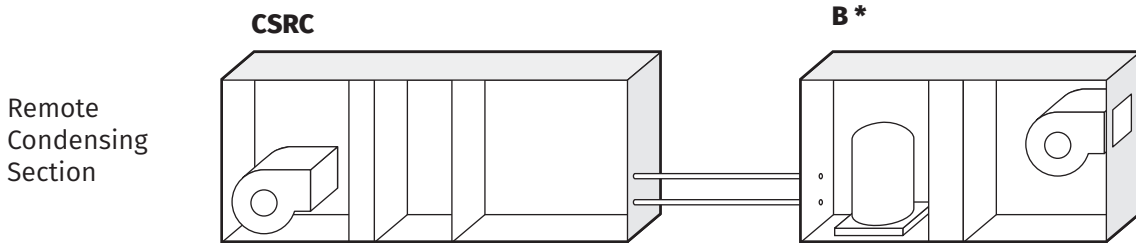
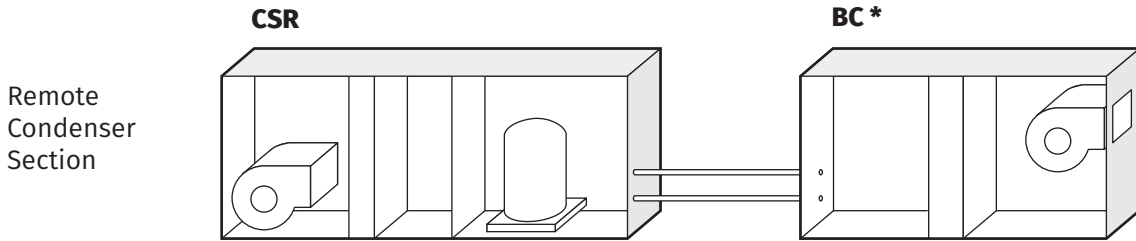

\* Remote condensers or condensing sections can also be water-cooled or propeller type.

### Air-Cooled Units

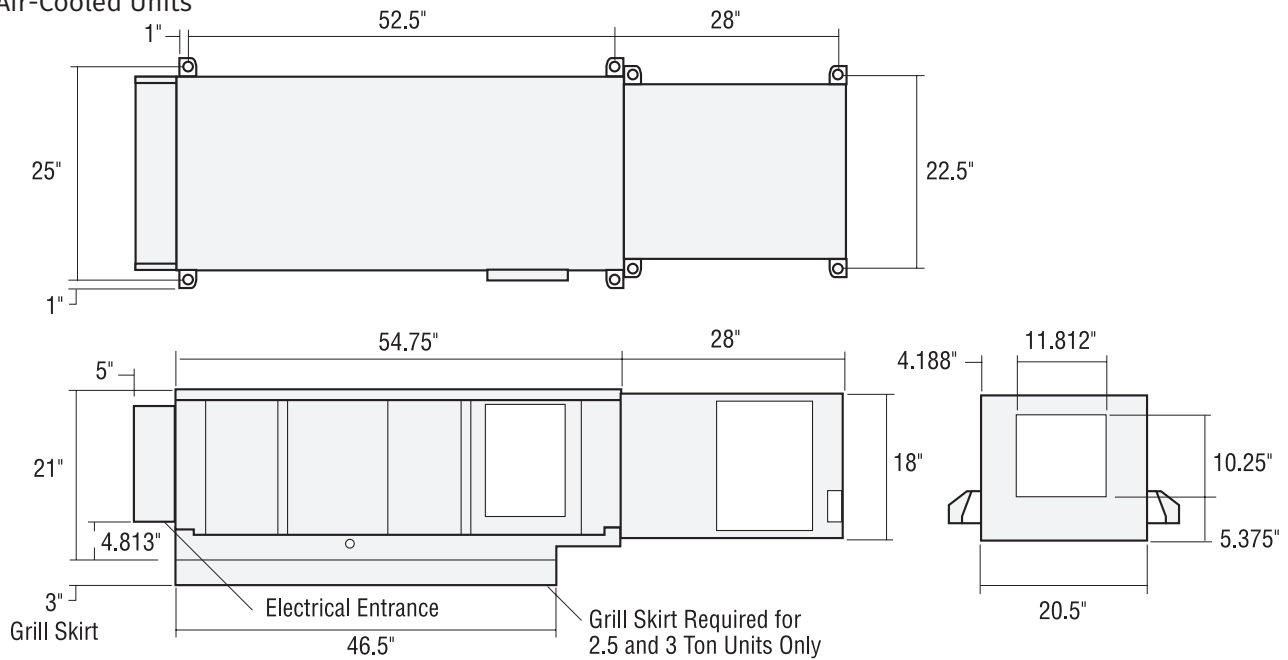

### Water-Cooled, Chilled Water, Air-Cooled with Remote Condenser/Condensing Unit

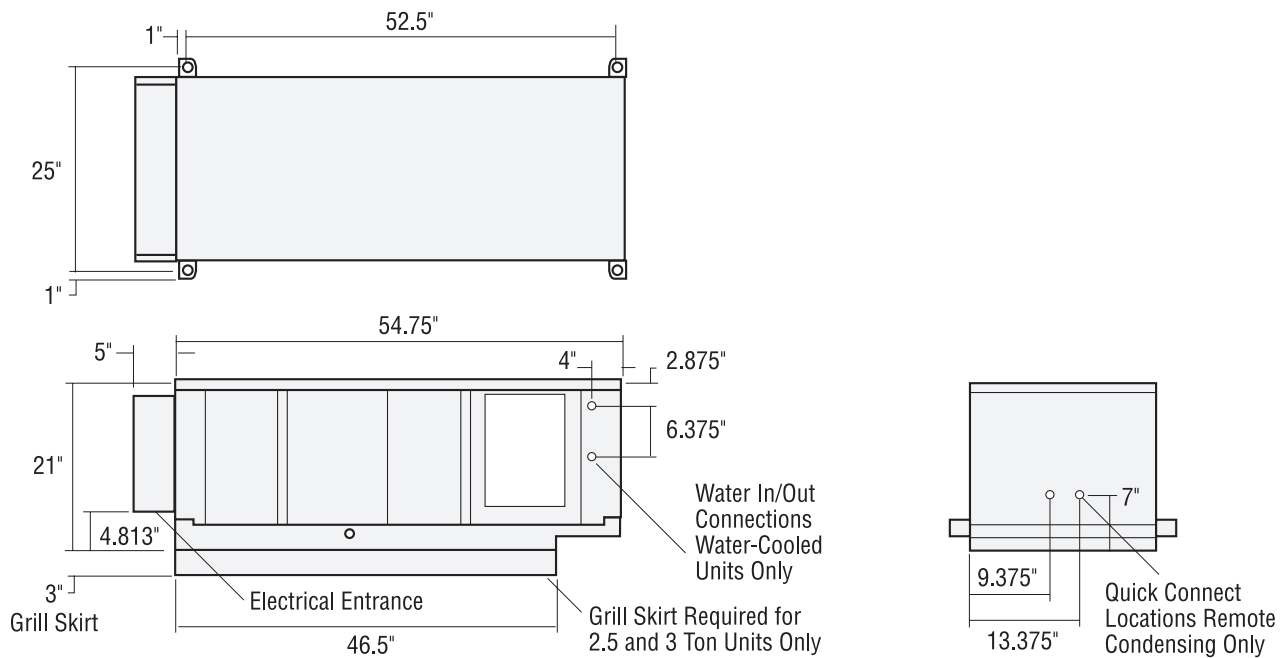

# Unique Solutions for All-Indoor HVAC Projects



**VertiCool Classic**  
Vertical, 3 - 30 Ton

**VertiCool Aurora**  
Vertical, 3 - 35 Tons

**VariCool®**  
VAV, 9 - 70 Tons

**VariCool® EZ-Fit**  
VAV, 12 - 90 Tons

**Alpha Aire**  
100 - 500 CFM



**Portable Cooling and Heating Units**  
3-30 Tons



**C13-Series Horizontal**  
2 - 10 Tons



**C-Series Horizontal**  
1 - 15 Tons  
Special Configuration  
Engineered to Order



**OmegaAir Horizontal and Vertical**  
100% Outside Air  
150 - 3000 CFM

Authorized Distributor:



## LIMITED WARRANTY

United CoolAir Units are backed by a 1 year limited warranty on parts and a 5 year limited warranty on the compressor (labor not included). Maintenance items such as filters and belts are excluded under this limited warranty.

## FACTORY TESTED

All units are functionally run tested before shipment to ensure a trouble-free start-up and unit commissioning. Industry proven components are used throughout to enhance system reliability and peace of mind.



Scan to learn more  
about all of our  
products!



491 East Princess Street, York, PA 17403 Phone: 717-843-4311 Fax: 717-854-4462  
email: [uca@unitedcoolair.com](mailto:uca@unitedcoolair.com) web: [www.unitedcoolair.com](http://www.unitedcoolair.com)



Copyright © by United CoolAir Corporation 2017. All rights reserved.  
Manufacturer reserves the right to make changes without notice.

