

THERMOWHEEL®

T Series Energy Recovery Wheel Systems

- 10 Year Parts and Labor Warranty - TF & TR
- 1,000,000 Hour L10 Life Bearings
- 25 Year Minimum Design Life
- Direct or Belt Drive

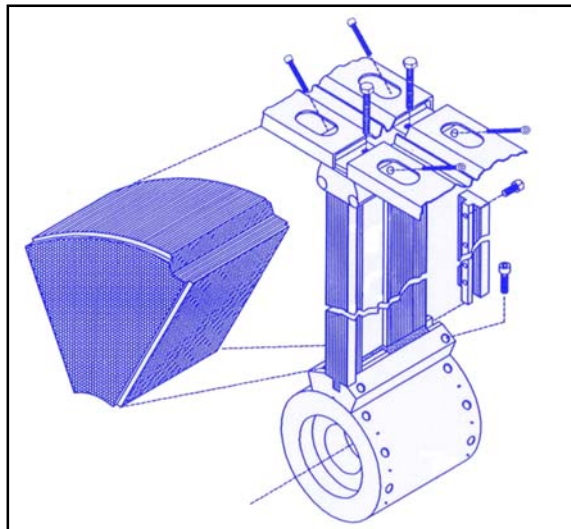

Engineering Reliability
and Performance
Re-Inventing The Wheel

Thermotech Enterprises
5110 W. Clifton Street
Tampa, FL 33634
Tel (813) 865-4701

www.thermotech-usa.com

 **THERMOTECHE ENTERPRISES**

The THERMOWHEEL® is the most reliable energy recovery wheel available. We back every product with a standard 3 or 10 year warranty. After performing hundreds of field installations of other manufacturers' wheels, the engineers at Thermotech have redesigned each of the major components to solve many of the problems we have encountered in the field.

Features:

25 Year Minimum Design life

- Eliminates Wheel Failures
- Low Maintenance
- High Performance
- Low Cost Per Life Cycle
- Flexibility in Installation
- Multiple Media Options

Shipped Fully Assembled or
Assemble on Site



The TR SERIES THERMOWHEEL® is designed from the ground up to be installed in the field as a replacement for existing heat recovery wheel products. The TR SERIES is a direct replacement for Berner, Cargocaire, SEMCO, Regenerative Heat Corp., Enreco, Governair, Flakt, Wing, Carnes, Heat Recovery Corp., Munters and others.

The TF SERIES THERMOWHEEL® is designed for new air handler applications in the 12,000 to 150,000 CFM range. One of the advantages of our unique design is that the unit can be shipped fully assembled or assembled in the field. If your facility requires a new heat recovery wheel or when limited access demands a field assembly of the wheel, the TF SERIES is the answer. The TF is available in sizes up to 21' in diameter.

The TC SERIES THERMOWHEEL® is designed for new air handler applications in the 500 to 20,000 CFM range and is shipped fully assembled in an aluminum frame. The TC is an economical alternative to the TF series wheel.

Because of our patented **THERMOWHEEL®** rotor design, the wheel is very strong and flat. Other manufacturers' large wheels, over 8 feet in diameter, can have problems with spoke deflection causing leakage around the seals. The **THERMOWHEEL®** rotor design features almost zero spoke deflection.

The Rotor Assembly:

Rotors consist of 3 main parts: hub and bearing assembly, spokes and rim. Wheels larger than 10 feet in diameter are built in 8 or 12 segments. Each segment consists of media supported by spokes and tensioned in place by the rim. TC Series wheels are a fully segmented 4 spoke design.



Rim Connector:

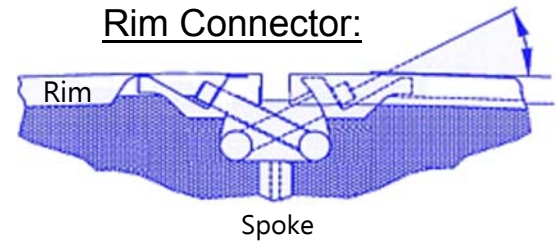

TR and TF Series wheels feature a patented rim and spoke design, which allows for each section of the wheel to be tensioned independently. This simplifies field assembly and provides a flatter, rounder and stronger wheel.

Spokes: Spokes provide the structural integrity to limit deflection of the wheel and to eliminate mechanical fatigue of the media.

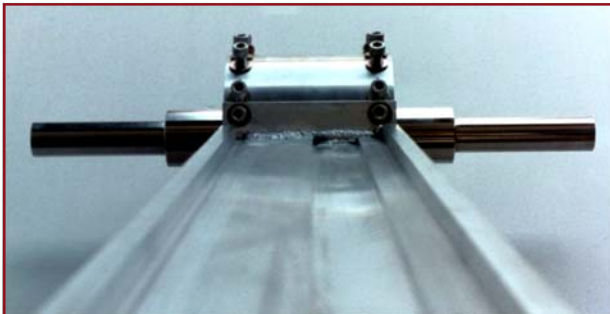

TR and TF Series spokes are extruded aluminum fashioned in the form of an "I" beam for added strength. TC series are aluminum bar stock fashioned in a grid box design. Each spoke has grooves which correspond to matching grooves machined into the media. This assures that each section of media is held securely in the exact position needed for a flat wheel.

Rims The rim holds each section of media in place and provides an area for the belts that drive the wheel to ride.

The rims are made from extruded aluminum and have "V" shaped grooves for the drive belts. This keeps the belts securely seated. The rims have ridges on the inside perimeter that fit into grooves machined in the media. This holds the media in proper position and provides a round and flat wheel.



THERMOWHEEL® T Series

The Hub and Bearing Assembly:

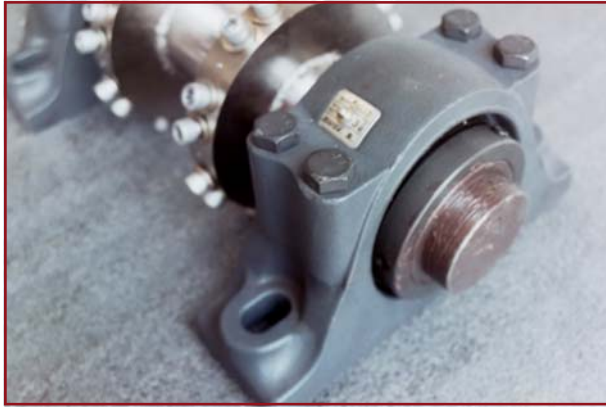

The hub and bearing assembly support the wheel in the casing.

Hub and bearings are the foundation on which the wheel is built. We use oversized bearings and machine each hub and shaft to the bearing manufacturer's tolerance. This provides the reliability needed for a minimum L-10 life of 1,000,000 hours.

The seals are the key to efficient operation of an energy recovery wheel.

The Seals:

Seals must be strong, flexible and not move once in place. To achieve this, the seal is manufactured from an extruded aluminum strip mated to a labyrinth design extruded rubber seal that is secured directly to the wheel frame.

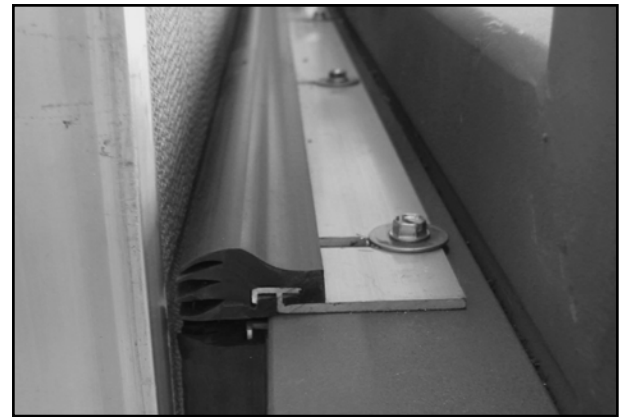

The seals can be set to 1/32" clearance from the media face, due to the fact that our "I" beam spokes feature almost zero deflection. This reduces leakage around the seals and provides for maximum performance and reliability.

The Motor Drive System:

The drive design is crucial to long term operation. A simple gravity tensioned twin "V" belt provides for outstanding performance and reliability. The belts ride in a groove on the rim to eliminate slippage and side to side belt movement. The drive is designed for a minimum life of 90,000 hours. A direct drive option is available with the speed reducer connected to an extended shaft via a keyway. All our motors feature variable or constant speed drive depending on the application. We use standard "V" belts, available at most supply stores, since this is the only part of a Thermowheel® which should ever need replacing.





Control System:

The control system and sensors measure the temperature of the different air streams and control the wheel speed for maximum efficiency.

Our control system can be configured to provide the proper operation of the energy recovery wheel in all conditions and environments. We can custom configure the sensors so that the customer obtains the data and control required to ensure the highest operational efficiency. We can provide the interface to any existing HVAC control system.

The ETL Listed, UL 508A Approved Control Panel is Enclosed in A NEMA 4 Cabinet.



Intertek

Media: **The media provides for the transfer of heat and moisture between the airstreams.**

Balanced Sieve 3 Å or 4 Å Media, is the most efficient media available. It features a micro engineered desiccant, performance tested in accordance with ASHRAE Standard 84-91 and ARI Standards 1060-01, and features a standard 2 part epoxy edge coating for anti-corrosion, anti-mold and anti-bacterial protection. Sensible media, and media for high temperature and corrosive environments are also available.

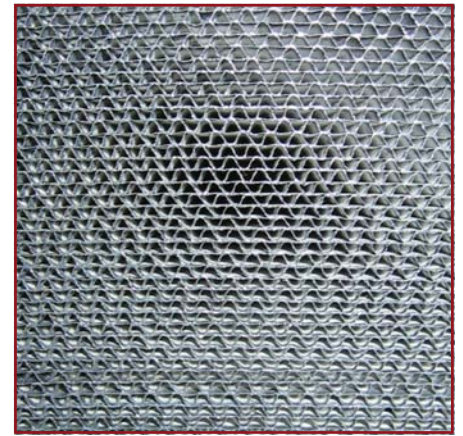

BALANCED SIEVE
Micro Engineered Desiccant Coating

Installation:

For retrofit or field assembly applications, the unique design of the THERMOWHEEL[®] provides a flatter, stronger, more reliable wheel.



The installation of TR and TF Series wheels can be performed by our trained technicians or by your staff with our supervision. The casing, when required, is constructed of tubular steel or aluminum and is of a modular design built in either 2 or more sections to provide for easy assembly.



THERMOWHEEL®



TF Series Dimensions

The sizing of the wheel is dependent on the energy recovery required. Sizing for specific needs can be calculated using the Thermo Select software or in the T Series engineering manual. Contact Thermotech for the software or manual. The model numbers are the effective face area in square feet divided by 10.

MS3 or 4 Media Performance @ 700 fpm = 72% @ 1000 fpm = 66%
 MH3 or 4 Media Performance @ 700 fpm = 77% @ 1000 fpm = 71%

Dimensions in Inches

Weight in Lbs.

Model #	A	T	B	C	CFM @ 700 fpm	CFM @ 1000 fpm	Motor HP	Weight Steel lbs.	Weight Aluminum lbs.
TF-1528	251	27	119	132	106,960	152,800	2	12,860	11,250
TF-1341	236	27	111 ½	124 ½	93,870	134,100	2	11,920	10,410
TF-1109	216	27	101 ½	114 ½	77,630	110,900	2	10,700	9,320
TF-920	198	23	94	104	64,400	92,000	2	7,270	6,040
TF-804	186	23	88	98	56,280	80,400	2	6,750	5,590
TF-723	174	21	82 ½	91 ½	56,610	72,300	1	4,880	4,010
TF-697	171	21	81	90	48,790	69,700	1	4,780	3,920
TF-671	168	21	79 ½	88 ½	46,970	67,100	1	4,700	3,850
TF-620	162	21	76 ½	85 ½	43,400	62,000	1	4,470	3,660
TF-572	156	21	73 ½	82 ½	40,040	57,200	1	4,270	3,490
TF-556	154	21	72 ½	81 ½	38,920	55,600	1	4,200	3,430
TF-526	150	21	70 ½	79 ½	36,820	52,600	1	4,070	3,320
TF-503	147	21	69	78	35,210	50,300	1	3,970	3,230
TF-474	143	21	67 ¾	75 ¼	33,180	47,400	¾	3,560	2,840
TF-460	141	21	66 ¾	74 ¼	32,200	46,000	¾	3,500	2,790
TF-432	137	21	64 ¾	72 ¼	30,240	46,000	¾	3,380	2,700
TF-418	135	21	63 ¾	71 ¼	29,260	41,800	¾	3,320	2,650
TF-398	132	21	62 ¼	69 ¾	27,860	39,800	¾	3,240	2,570
TF-385	130	21	61 ¼	68 ¾	26,950	38,500	¾	3,170	2,520
TF-359	126	21	59 ¼	66 ¾	25,130	35,900	¾	3,050	2,410
TF-347	124	21	58 ¼	65 ¾	24,290	34,700	¾	2,990	2,290
TF-329	120	20	57 ½	62 ½	23,303	32,900	½	2,580	1,850
TF-311	117	20	55 ½	61 ½	21,770	31,100	½	2,490	1,780
TF-294	114	20	54 ½	59 ½	20,580	31,100	½	2,420	1,730
TF-282	112	20	53 ½	58 ½	19,740	28,200	½	2,370	1,690
TF-261	108	20	51 ½	56 ½	18,270	26,100	½	2,280	1,620
TF-245	105	20	49 ½	55 ½	17,150	24,500	½	2,210	1,570
TF-225	101	20	47 ½	53 ½	15,750	22,500	½	2,110	1,500
TF-215	99	20	46 ½	52 ½	15,050	21,500	½	2,070	1,460
TF-200	96	20	45 ½	50 ½	14,000	20,000	½	2,000	1,410
TF-191	94	20	44 ½	49 ½	13,370	19,100	½	1,950	1,380
TF-182	92	20	43 ½	48 ½	12,740	18,200	½	1,900	1,340
TF-173	89½	19	42 ½	47 ½	12,110	17,300	⅓	1,310	930
TF-166	87½	19	41 ½	46 ½	11,620	16,600	⅓	1,260	890
TF-152	84½	19	39 ¾	44 ½	10,640	15,200	⅓	1,210	850
TF-144	82½	19	38 ¾	43 ½	10,080	14,400	⅓	1,180	820
TF-136	80½	19	37 ¾	42 ½	9,520	13,600	⅓	1,140	800
TF-128	78½	19	36 ¾	41 ½	8,960	12,800	⅓	1,110	770
TF-121	76½	19	35 ¾	40 ½	8,470	12,100	⅓	1,080	750
TF-114	74½	19	34 ¾	39 ½	7,980	11,400	⅓	1,050	730
TF-107	72½	19	33 ¾	38 ½	7,490	10,700	⅓	1,020	700
TF-96	69½	19	32 ¾	37 ½	6,720	9,600	⅓	970	670
TF-87	66½	19	30 ¾	35 ½	6,090	8,700	⅓	930	640
TF-81	64½	19	29 ¾	34 ½	5,670	8,100	⅓	900	620

TC Series Dimensions

MS3or 4 Media Performance @ 700 fpm = 72% @ 1000 fpm = 66%
 MH3 or 4 Media Performance @ 700 fpm = 77% @ 1000 fpm = 71%

MODEL NUMBER	Dimensions in Inches				Weight in Lbs.			
	A	T	B	C	CFM @ 700 fpm	CFM @ 1000 fpm	Aluminum Frame	Motor HP
TC-201	92.00	19.00	44.13	47.88	14,070	20,100	912	1/3
TC-183	88.00	19.00	42.13	45.88	12,810	18,300	857	1/3
TC-165	84.00	19.00	40.13	43.88	11,550	16,500	796	1/3
TC-149	80.00	19.00	38.13	41.88	10,430	14,900	745	1/3
TC-133	76.00	19.00	36.13	39.88	9,310	13,300	698	1/3
TC-118	72.00	19.00	34.13	37.88	8,260	11,800	649	1/3
TC-104	68.00	19.00	32.13	35.88	7,280	10,400	606	1/3
TC-91	64.00	19.00	30.13	33.88	6,552	9,100	561	1/3
TC-82	60.00	18.00	28.50	31.50	5,740	8,200	356	1/4
TC-71	56.00	18.00	26.50	29.50	4,970	7,100	327	1/4
TC-60	52.00	18.00	24.50	27.50	4,200	6,000	294	1/4
TC-50	48.00	18.00	22.50	25.50	3,500	5,000	267	1/4
TC-41	44.00	18.00	20.50	23.50	2,870	4,100	237	1/4
TC-33	40.00	18.00	18.50	21.50	2,310	3,300	213	1/4
TC-22	34.00	18.00	15.50	18.50	1,540	2,200	180	1/4
TC-14	28.00	18.00	12.50	15.50	980	1,400	151	1/4

For both TF and TC series, weights are approximate and will vary depending on media type. Add 8% for MH3 or 4 Media. Subtract 5% for ECA media

Problems solved by Thermowheel®

Most wheels don't fail because the media isn't doing its job.
 They fail because of structural design faults.



Seal Failures

Common failures like these pictured here are caused by flawed designs.

The T Series THERMOWHEEL® solves all of these problems and more



Rim Failures



Delamination

Engineering Reliability And Performance



Media Separation

Casing Frame Structure:

The structural casing can be provided in one, two or more sections. When assembled it shall allow for a maximum 1/32" rotor deflection during maximum rated airflow conditions.

Purge Section:

A purge section shall be provided to eliminate transfer of exhaust air into the supply air, and shall be field adjustable to provide the desired purge air volume.

Hub and Bearings:

External bearings shall be sized to provide a minimum L-10 life of 1,000,000 hours of operation, and shall be changeable without a complete disassembly of the rotor. Shaft shall be machined as to provide a shoulder against the bearings for a positive locked position to eliminate any lateral movement of the rotor due to set screw failure or shaft wear.

Spokes:

The spokes shall be made of extruded aluminum with an "I" beam shape to limit deflection of the rotor to 1/32" for the maximum rated airflow. Spokes shall consist of a primary and a secondary spoke to allow for easy field assembly. Surfaces to be serrated for increased friction and air turbulence across the seals.

Rims:

Rims shall be made of 2 extruded aluminum sections. 1 inner rim and 1 outer rim with grooves for the twin "V" belts, and guide flanges for securing the media. The 2 sections shall be welded together to form a tubular structure for improved strength in order to maintain an accurate radius and rotor roundness during the installation process.

Rim Joint:

The rim joint shall connect the spoke ends and the rim ends together in such a way that the heat transfer media can be installed under field conditions without any media deformation or misfits causing future problems. The rim joints shall provide a gradual compression of each section by independently applying increased tension of the rim bolts without the use of any special tools or devices.

Rotor Media:

The rotor media must be provided in segments. Each media segment must be machined to fit in between a primary and secondary spoke and a guiding flange of the outside rim. Each segment of media must be compressed independently of all other segments during the assembly process without causing any angular deformation and resulting misfits between the spokes and media parts, and to provide a wheel with a flatness of +/- 1/32". No adhesives or silicone shall be necessary to secure the media in place in order to allow for future replacement in the event of damage to a section. The rotor system must be able to accommodate all acceptable media types for applications requiring equal sensible and latent recovery.

Seals:

The seals shall be of a maintenance free "non-contact" type to eliminate wear, excessive drag and resulting added horsepower required for the motor drive system, while still being capable of resisting high pressure differences up to 12 in.wc. without deflection causing leaks.

Drive System:

The drive must be gravity tensioned and shall use 2 standard "B" section V- belts to drive the rotor. The speed reducer must be grease lubricated, maintenance free with a flexible Love-Joy input coupling or a Direct Drive Motor and Speed reducer shall be attached to the extended shaft via a key-way.

Speed Control:

The speed control system shall be a variable frequency inverter operating a standard inverter rated AC motor, capable of operating the rotor from 1/4 rpm to 20 rpm or to whatever is required for the type of media used.

It shall integrate with the temperature control system to provide the required supply air temperature.

Temperature or Enthalpy Controller:

The Wheel Controls shall monitor the temperature or Enthalpy conditions of the Airflow streams and adjust the wheel speed to maintain the programmed setpoints. Adjustable set points shall be for the heating mode discharge temperature, summer/winter changeover and for wheel frost control.

Maintenance:

The entire rotor and wheel assembly shall require only limited maintenance of biannual greasing of the main bearings and inspection of the drive system.

Warranty:

A standard 10 or 3 year material and labor warranty covering all materials supplied and installed by Thermotech.

* U.S. patent # 6,422,299 Canadian patent # 2,373,417

** The entire specifications for TR, TF and TC Series Thermowheel® are available at: thermotech-usa.com

*** TC Series wheels feature a 1 piece frame and single rim. Fixed rim connector with a grid box spoke design. Adhesives are used and entire rotor can be removed via side access.

Thermotech Enterprises

5110 W. Clifton Street

Tampa, FL 33634

Tel (813) 865-4701

www.thermotech-usa.com

 **THERMOTECH ENTERPRISES**