

Fans & Blowers

Twin City

Defining Innovation.

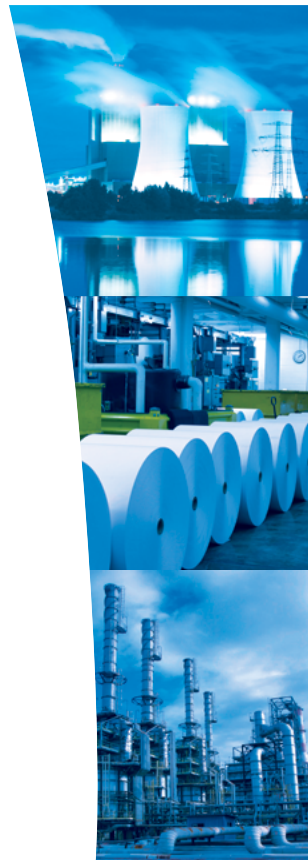
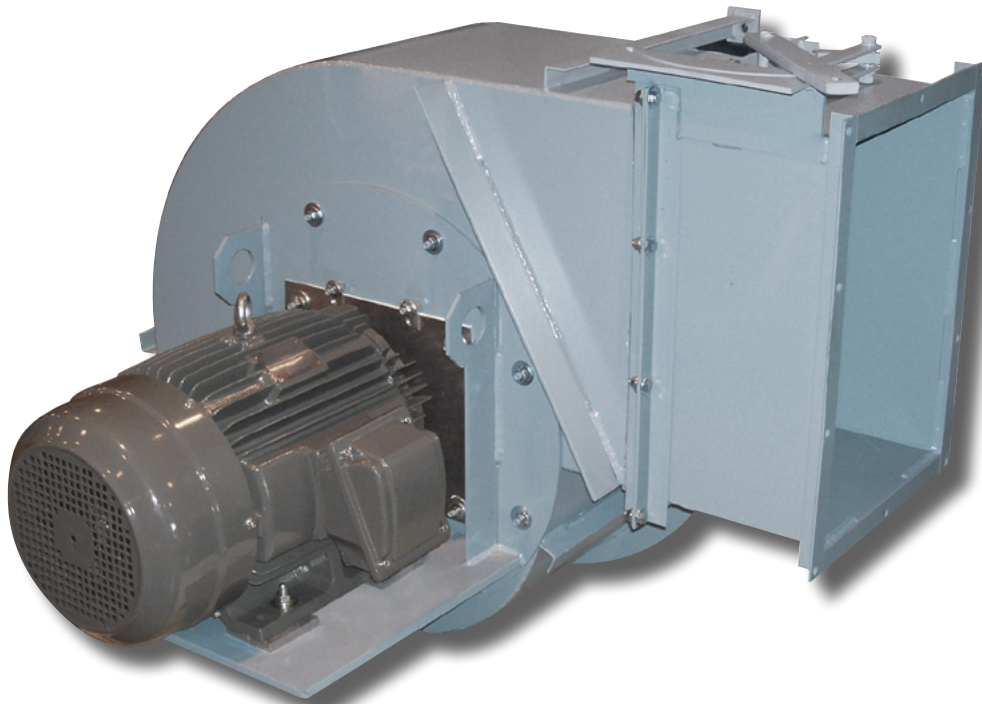

DIRECT DRIVE BACKWARD INCLINED FANS FOR DUST COLLECTORS

TYPE TCBI

Direct Drive Backward Inclined Fans

Twin City Fan & Blower offers the type TCBI Backward Inclined fan specially designed for dust collector mounting. The TCBI is available in sizes 3 to 30.

The TCBI features a high-efficiency, non-overloading impeller suitable for handling a relatively clean airstream.

The impeller mounts directly to the motor in an AMCA arrangement 4. The rotating assembly is precision balanced prior to shipment.

Size & Performance

- Available in eight sizes with impeller diameters of 14³/₁₆" to 19¹¹/₁₆"
- Direct drive (Arrangement 4)
- Capacities from 1,000 CFM to 12,700 CFM (at 3525 RPM)
- Static pressures to 18" w.g.
- Horizontal (shaft) or vertical mounting configurations available (support for horizontal mount is by customer)

Construction Features

- Backward inclined, single-thickness, blades welded to backplate and frontplate of impeller
- Impeller easily removable from motor-side of fan housing
- Continuously welded housing for strength, durability, and extended service life
- Standard shaft seal

Fan Weights

FAN SIZE	WEIGHT (LBS.)
3	297
5	347
7.5	347
10	347
15	285
20	285
25	333
30	333

NOTE:

Estimated weights do not include the weight of the motor.



Fan shown with optional round inlet flange



Fan shown with optional round inlet flange and bolt-on outlet control damper



Optional 4-sided outlet flange



Optional bolt-on outlet control damper

Optional Accessories

- Built-in or bolt-on outlet control damper
- Outlet silencer
- Outlet flange, punched
- Aluminum impeller for sizes 3 - 10. (Aluminum is standard on sizes 15 and larger)
- Explosion proof motors
- Premium efficiency motors
- Round or rectangular inlet flange

Sound Pressure Data

FAN SIZE	WITHOUT SILENCER (dBA)	WITH SILENCER (dBA)	PRESSURE DROP (in. w.g.)
3	87	69	0.4
5	89	68	0.5
7.5	91	70	0.8
10	92	75	1.1
15	98	74	1.1
20	98	76	1.4
25	100	75	0.9
30	100	75	1.4

NOTES:

1. Sound measurements were obtained at fan operating at 3525 RPM.
2. Sound pressure levels will vary depending on installation and operating conditions.

Performance Data

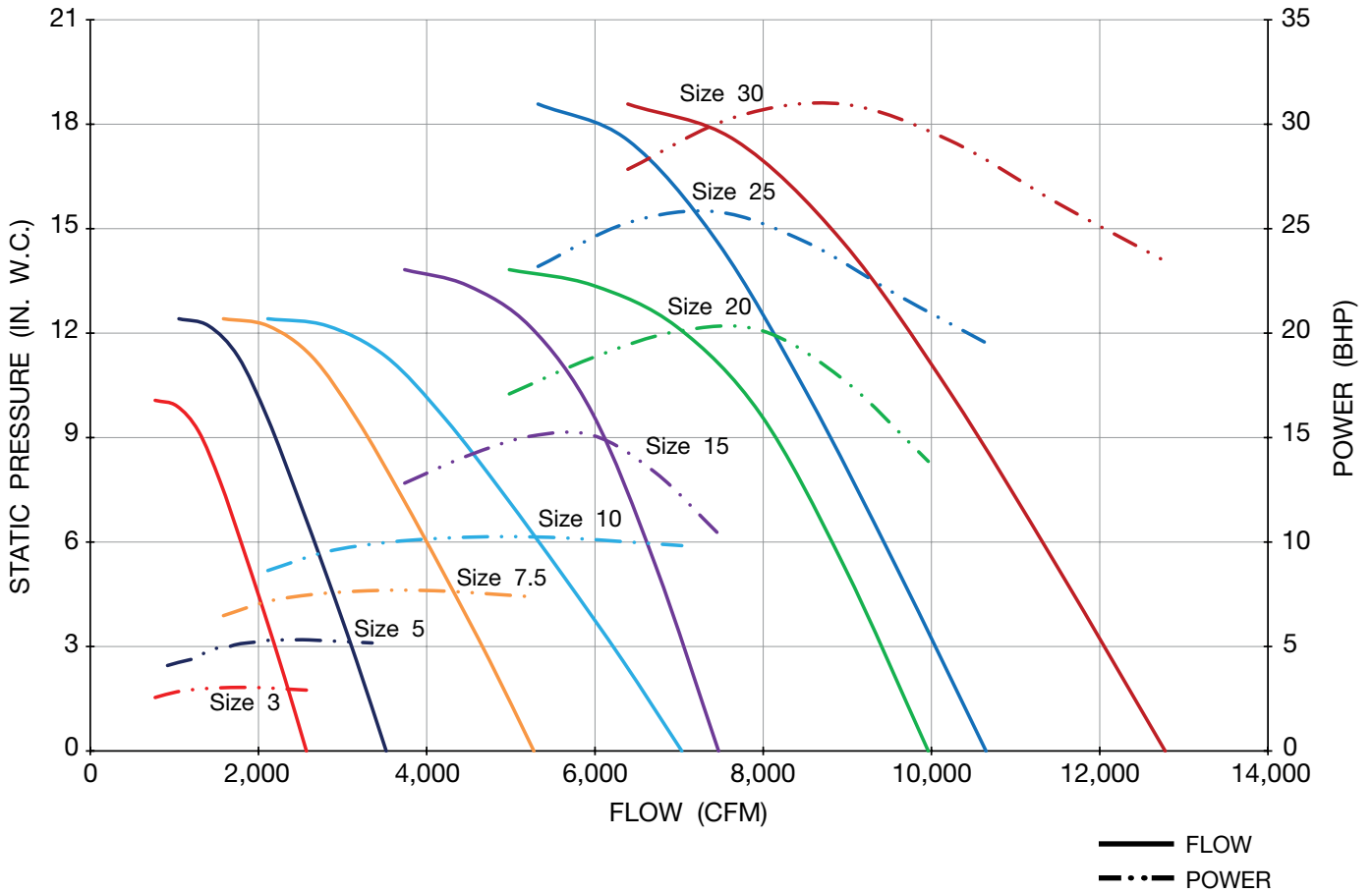

Performance (3525 RPM)

FAN SIZE	0.50" SP		1" SP		1.50" SP		2" SP		3" SP		4" SP		5" SP		6" SP		7" SP		8" SP	
	CFM	BHP	CFM	BHP	CFM	BHP	CFM	BHP	CFM	BHP	CFM	BHP	CFM	BHP	CFM	BHP	CFM	BHP	CFM	BHP
3	2510	2.93	2449	2.94	2388	2.95	2325	2.97	2197	3.00	2065	3.03	1930	3.04	1792	3.04	1654	3.04	1503	3.02
5	3452	4.93	3384	4.95	3317	4.97	3248	4.99	3108	5.03	2963	5.07	2816	5.10	2666	5.12	2514	5.13	2360	5.13
7.5	5175	7.40	5075	7.43	4974	7.46	4871	7.48	4662	7.54	4445	7.60	4224	7.65	4001	7.68	3774	7.69	3542	7.69
10	6901	9.86	6767	9.90	6632	9.94	6495	9.97	6215	10.05	5926	10.13	5632	10.20	5334	10.24	5031	10.26	4721	10.25
15	7404	10.69	7338	10.99	7271	11.28	7203	11.56	7064	12.12	6919	12.65	6770	13.16	6615	13.64	6457	14.10	6292	14.53
20	9874	14.26	9786	14.65	9696	15.04	9604	15.42	9417	16.16	9224	16.87	9024	17.55	8818	18.19	8608	18.80	8388	19.37
25	10551	19.74	10452	19.95	10352	20.16	10252	20.38	10051	20.81	9847	21.26	9642	21.72	9435	22.20	9227	22.71	9018	23.23
30	12659	23.69	12540	23.94	12420	24.19	12300	24.45	12058	24.98	11814	25.51	11567	26.06	11319	26.64	11072	27.25	10821	27.87

FAN SIZE	9" SP		10" SP		11" SP		12" SP		13" SP		14" SP		15" SP		16" SP		17" SP		18" SP	
	CFM	BHP	CFM	BHP	CFM	BHP	CFM	BHP	CFM	BHP	CFM	BHP	CFM	BHP	CFM	BHP	CFM	BHP	CFM	BHP
3	1328	2.98																		
5	2203	5.11	2030	5.08	1836	5.02														
7.5	3304	7.67	3043	7.62	2751	7.53														
10	4403	10.22	4056	10.16	3670	10.04														
15	6112	14.90	5902	15.17	5640	15.26	5302	15.11	4791	14.58										
20	8149	19.87	7869	20.23	7520	20.34	7067	20.14	6387	19.44										
25	8804	23.74	8583	24.21	8356	24.64	8125	25.04	7886	25.40	7630	25.69	7343	25.84	7022	25.81	6645	25.56	6091	24.82
30	10566	28.48	10302	29.05	10030	29.56	9752	30.05	9465	30.48	9156	30.82	8811	31.01	8426	30.97	7972	30.67	7308	29.78

NOTES:

1. Performance shown is for fans with a free inlet and ducted outlet.
2. Performance ratings do not include the effects of appurtenances (accessories).

Dimensional Data

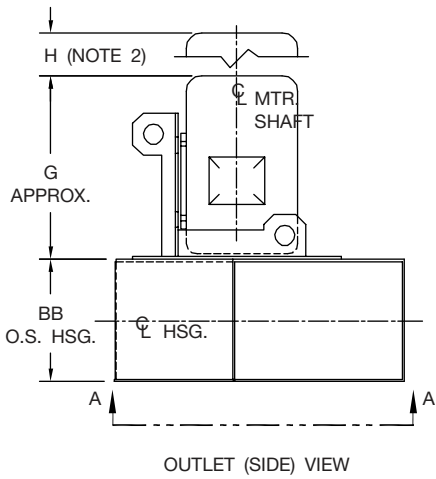
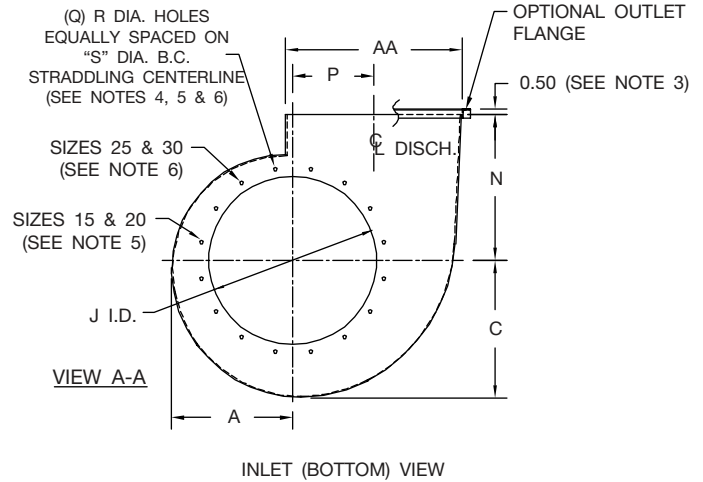
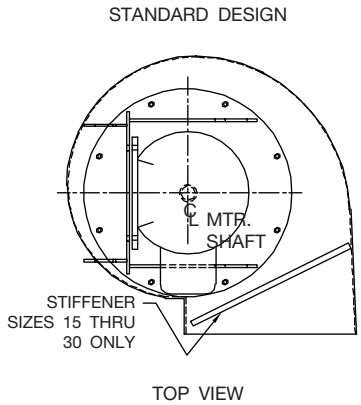

NOTES:

1. "CW" rotation shown; "CCW" rotation similar but opposite.
2. Necessary clearance for wheel removal.
3. Dimension shown for use with outlet flange option.
4. Fans with inlet flange (square or round) do not have mounting holes in housing inlet side.
5. Sizes 15 & 20 eliminate this hole.
6. Sizes 25 & 30 eliminate this hole.
7. Damper handle should always be located at the motor side.

FAN SIZE	A	B	C	D	E	F	G	H	J	K	L	M	N	P	Q	R	S
3	10.25	18.19	11.63	22.50	13.75	9.38	17.00	6.00	13.81	17.81	15.00	36.00	14.13	7.63	8	0.44	17.25
5	11.44	19.75	12.94	22.63	14.44	9.75	17.00	6.00	15.38	19.50	17.50			8.50			
7.5	11.44	19.75	12.94	23.00	15.69	10.38	21.00	7.00	15.38	19.50	17.50			8.50			
10	11.44	19.75	12.94	23.13	16.44	10.75	21.00	8.00	15.38	19.50	17.50	60.00	17.13	8.94	16	0.56	28.50
15	14.94	22.81	18.00	26.25	17.00	11.00	26.00	8.00	19.50	23.50	21.50			8.94			
20	14.94	22.81	18.00	26.75	18.94	12.00	26.00	10.00	19.50	23.50	21.50			8.94			
25	16.69	24.94	20.06	26.63	18.25	11.63	28.00	10.00	21.38	25.50	23.50	60.00	17.13	9.94	16	0.56	28.50
30	16.69	24.94	20.06	26.88	19.25	13.13	28.00	10.00	21.38	25.50	23.50			9.94			

FAN SIZE	AA	BB	CC	DD	EE	FF	GG	HH	JJ	KK	LL	MM
3	13.44	8.75	15.94	11.25	5.00	4.94	5.13	4.00	10.00	21.00	6.63	6.50
5	14.81	9.44	17.31	12.00	5.44	5.44	5.50	4.38	10.69			
7.5	14.81	10.75	17.31	13.25	5.44	5.44	6.13	5.00	12.00			
10	14.81	11.50	17.31	14.00	5.44	5.44	6.50	5.38	12.75	26.00	8.25	8.25
15	20.00	12.00	22.50	14.50	7.19	7.13	6.75	5.63	13.25			
20	20.00	14.00	22.50	16.50	7.19	7.13	7.75	6.63	15.25			
25	22.13	13.25	24.63	15.75	7.88	7.88	7.38	6.25	14.50	26.00	8.25	8.25
30	22.13	14.25	24.63	16.75	7.88	7.88	7.88	6.75	15.50			

BC1003044A

DIMENSIONS ARE SUBJECT TO CHANGE. CERTIFIED DRAWINGS AVAILABLE UPON REQUEST.

Dimensional Data - Accessories

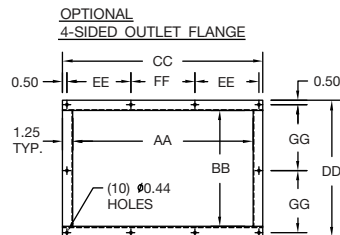
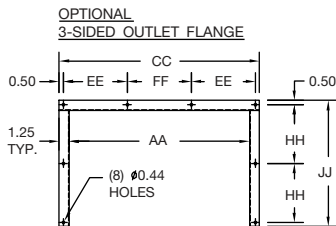
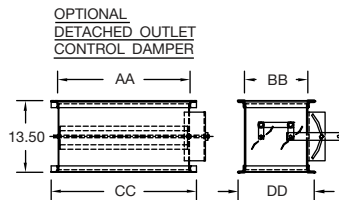
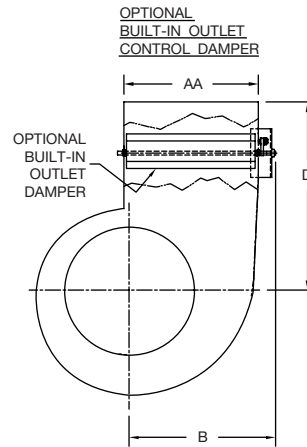
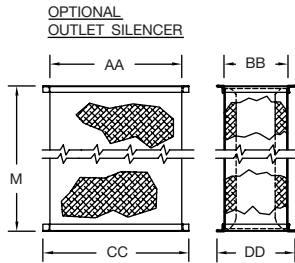
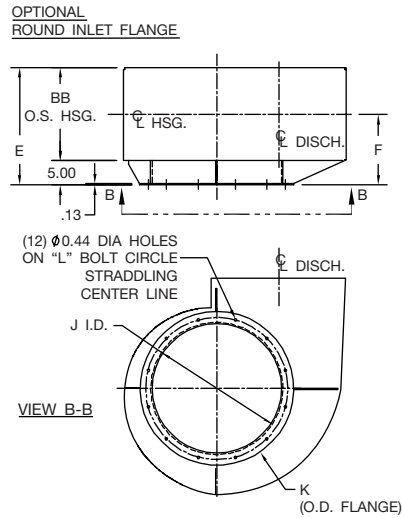
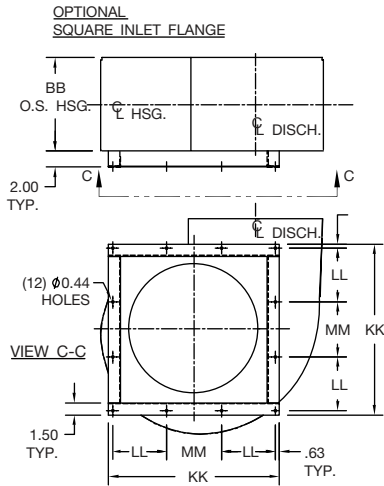

Typical Specifications

Type TCBI Direct Drive Backward Inclined Fans for Dust Collectors, where indicated on drawings and schedules, shall be of the non-overloading design, and shall be of the size and capacity as indicated in the fan schedule. Direct drive, backward inclined dust collector fans shall be as manufactured by Twin City Fan & Blower, Minneapolis, Minnesota.

Fans shall have a sharply rising pressure characteristic extending through the operation range. Fans shall have non-overloading design with self-limiting horsepower characteristics and shall reach a peak in the normal selection area.

PERFORMANCE — Fan ratings shall be based on tests conducted in accordance with AMCA Standard 211 and 311 for air moving devices.

HOUSINGS — TCBI fan housings are to be of heavy gauge, continuously welded construction. Housings with lock seams or partially welded construction are not acceptable. Housings shall be suitably braced to prevent vibration or pulsation. Fan housings shall have tapered spun, aerodynamically designed inlet cones or shrouds providing stable flow and high rigidity. Wheels shall be of the non-overloading type.

WHEEL — TCBI backward inclined wheels shall be single thickness plate type, continuously welded to the rim and back plate, designed for maximum efficiency and quiet operation. Partial welding will not be acceptable on backward inclined blades. All TCBI wheels shall be statically and dynamically balanced. The complete fan assembly shall be test balanced at the operating speed prior to shipment.

MOTOR — Fan motors shall be continuous duty, ball bearing, variable torque type suitable for operation on voltage, phase and hertz, as listed in the fan schedule, matched to the fan size.

FINISH AND COATING — The entire fan assembly shall be thoroughly degreased and washed before application of a heavy-duty industrial coating. After the fan is completely assembled, a topcoat is applied to the entire unit.

OPTIONAL ACCESSORIES — Where required the fans shall be provided with inlet flange (square or round), outlet flange, outlet volume control damper (built-in or bolt-on), outlet silencer, outlet screen and aluminum wheel (standard on sizes 15 and larger).

FACTORY RUN TEST — All fans prior to shipment shall be completely assembled and test run as a unit at operating speed or maximum RPM allowed for the particular construction class. Each wheel shall be statically and dynamically balanced in accordance with ANSI/AMCA 204-96 "Balance Quality and Vibration Levels for Fans", Balance Quality Grade G6.3. Balance readings shall be taken by electronic type equipment in the axial, vertical, and horizontal directions on each of the bearings. Records shall be maintained and a written copy shall be available upon request.

SUBMITTALS — Submittals for approval of equipment shall include copies of outline drawing and performance curves showing point of operation.

GUARANTEE — The manufacturer shall guarantee the workmanship and materials for its TCBI Direct Drive Backward Inclined Fans for Dust Collectors for at least one (1) year from startup or eighteen (18) months from shipment, whichever occurs first.

Field Applications



Arrangement 4VI with optional outlet silencer, built-in control damper and round inlet flange mounted on a cartridge-style dust collector.



Arrangement 4VI (vertical, inlet mounted) on baghouse dust collector.



Arrangement 4HI (horizontal, inlet mounted) on a cartridge-style dust collector (support by customer).

INDUSTRIAL & COMMERCIAL FANS

Centrifugal Fans | Utility Sets | Plenum & Plug Fans | Inline Centrifugal Fans

Mixed Flow Fans | Tubeaxial & Vaneaxial Fans | Propeller Wall Fans | Propeller Roof Ventilators

Centrifugal Roof & Wall Exhausters | Ceiling Ventilators | Gravity Ventilators | Duct Blowers

Radial Bladed Fans | Radial Tip Fans | High Efficiency Industrial Fans | Pressure Blowers

Laboratory Exhaust Fans | Filtered Supply Fans | Mancoolers | Fiberglass Fans | Custom Fans

Fans & Blowers

Twin City



A Twin City Fan Company

TWIN CITY FAN & BLOWER | WWW.TCF.COM

5959 Trenton Lane N | Minneapolis, MN 55442 | Phone: 763-551-7600 | Fax: 763-551-7601